



C231SS

Caple Premium MF Oven Stainless Steel



INSTRUCTION MANUAL

Dear Customer,

Thank you for having purchased and given your preference to our product.

The safety precautions and recommendations within this booklet are for your own safety and that of others. They will also provide a means by which to make full use of the features offered by your appliance.

Please preserve this booklet carefully. It may be useful in future, either to yourself or to others in the event that doubts should arise relating to its operation.

This appliance must be used only for the task it has explicitly been designed for, that is for cooking foodstuffs. Any other form of usage is to be considered as inappropriate and therefore dangerous.

The manufacturer declines all responsibility in the event of damage caused by improper, incorrect or illogical use of the appliance.

DECLARATION OF CE CONFORMITY

- This oven has been designed to be used only for cooking. Any other use (such as heating a room) is improper and dangerous.
- This oven has been designed, constructed, and marketed in compliance with:
 - safety requirements of EEC Directive "Low voltage" 2006/95
 - safety requirements of EEC Directive "EMC" 89/336;
 - requirements of EEC Directive 93/68.



IMPORTANT INFORMATION FOR CORRECT DISPOSAL OF THE PRODUCT IN ACCORDANCE WITH EC DIRECTIVE 2002/96/EC.

At the end of its working life, the product must not be disposed of as urban waste. It must be taken to a special local authority differentiated waste collection centre or to a dealer providing this service.

Disposing of a household appliance separately avoids possible negative consequences for the environment and health deriving from inappropriate disposal and enables the constituent materials to be recovered to obtain significant savings in energy and resources. As a reminder of the need to dispose of household appliances separately, the product is marked with a crossed-out wheeled dustbin.

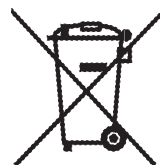

IMPORTANT PRECAUTIONS AND RECOMMENDATIONS

- After having unpacked the appliance, check to ensure that it is not damaged. If you have any doubts, do not use it and contact the store from where you purchased it.
- Packing materials (i.e. plastic bags, polystyrene foam, nails, packing straps, etc.) should not be left around within easy reach of children, as these may cause serious injuries.
- Do not attempt to modify the technical characteristics of the appliance as it may become dangerous to use.
- Do not line the oven walls with aluminium foil. Do not place baking trays or the drip tray on the base of the oven chamber.
- Do not carry out cleaning or maintenance operations on the appliance without having previously disconnected it from the electric power supply.
- If you should decide not to use this appliance any longer (or decide to substitute an older model), before disposing of it, it is recommended that it be made inoperative in an appropriate manner in accordance to health and environmental protection regulations, ensuring in particular that all potentially hazardous parts be made harmless, especially in relation to children who could play with old appliances.

IMPORTANT PRECAUTIONS AND RECOMMENDATIONS FOR USE OF ELECTRICAL APPLIANCES

Use of any electrical appliance implies the necessity to follow a series of fundamental rules. In particular:

- Never touch the appliance with wet hands or feet;
- do not operate the appliance barefooted;
- do not allow children or disabled people to use the appliance without your supervision.

The manufacturer cannot be held responsible for any damages caused by improper, incorrect or unreasonable use of the appliance.

USING THE OVEN FOR THE FIRST TIME

You are advised to carry out the following operations:

- Assemble the interior of the oven as described under the heading "Cleaning and maintenance"
- Switch the empty oven ON at maximum temperature for about two hours to eliminate traces of grease and smell from the components.
- Let the oven cool down, switch off the electrical supply, then clean the inside of the oven with a cloth soaked in water and neutral detergent and dry thoroughly.

Control panel

1

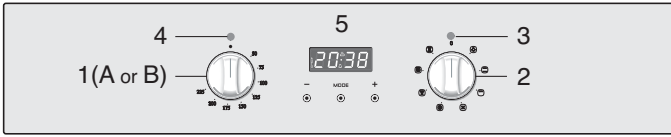

Fig. 1.1

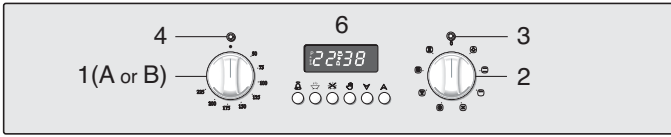

Fig. 1.2

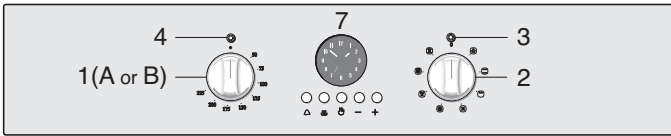

Fig. 1.3

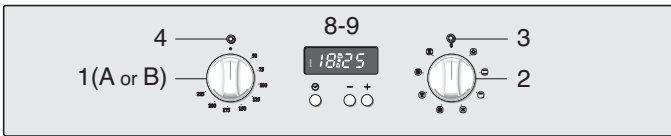

Fig. 1.4

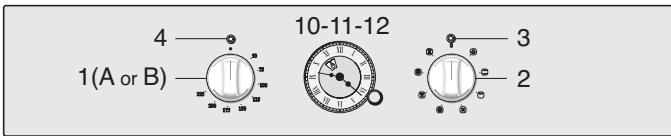

Fig. 1.5

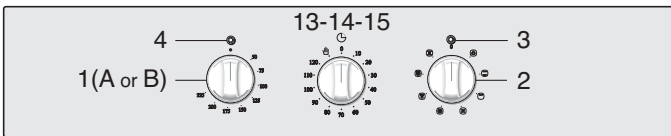
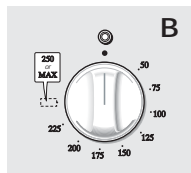
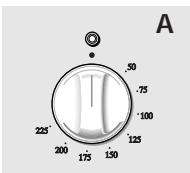

Fig. 1.6



TYPES OF THERMOSTAT

Depending on the models the thermostat could be of type A (50 to 225°C) or type B (50 to 250°C or 50 to MAX).

Fig. 1.7

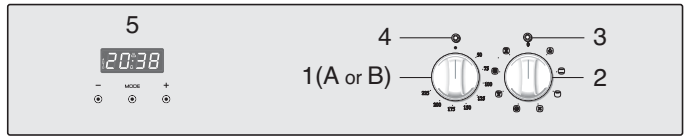

Fig. 1.8

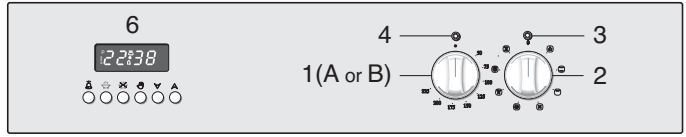

Fig. 1.9

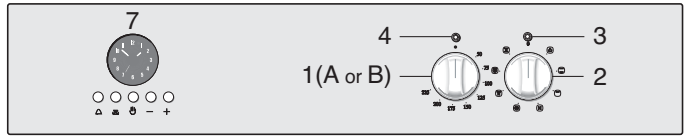

Fig. 1.10

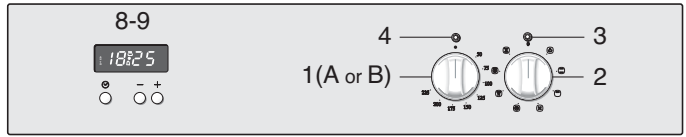

Fig. 1.11

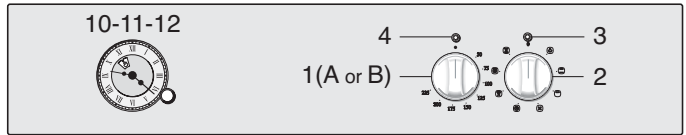
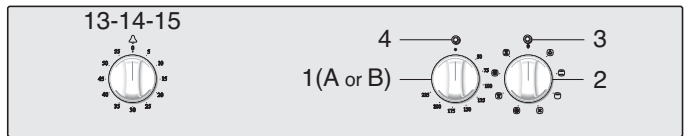

Fig. 1.12



CONTROL PANEL

1. Oven thermostat knob (type A or B)
2. Function selector knob
3. Power on indicator lamp
4. Oven temperature indicator lamp
5. Clock and timer with "Touch-Control" keys
6. Electronic programmer
7. Electronic clock/Programmer
8. Electronic clock/end cooking timer
9. Electronic clock
10. Clock programmer (start-end)
11. Electric clock with alarm
12. Electric clock
13. Timer (120' cut-off)
14. 60' alarm
15. 120' alarm



GENERAL FEATURES

As its name indicates, this is an oven that presents particular features from an operational point of view.

In fact, it is possible to insert 7 different programs to satisfy every cooking need. The 7 positions, thermostatically controlled, are obtained by 4 heating elements which are:

- Lower element 1300 W
- Upper element 1000 W
- Grill element 2000 W
- Circular element 2200 W

NOTE:

Upon first use, it is advisable to operate the oven at the maximum temperature (thermostat knob on position 225) for 60 minutes in the position  and  to eliminate possible traces of grease on the heating elements.

Repeat the operation for another 15 minutes with the grill element on as explained in the chapters GRILLING and USE OF THE GRILL.

WARNING:

The door is hot, use the handle.

During use the appliance becomes hot. Care should be taken to avoid touching heating elements inside the oven.

GREASE FILTER (some models only)

- A special screen is provided at the back of the oven to catch grease particles, mainly when meat is being roasted (see page 37).
- When baking pastry etc. this filter should be removed.
- Always clean the filter after cooking as any solid residues on it might adversely affect the oven performance.

OPERATING PRINCIPLES

Heating and cooking in the MULTI-FUNCTION oven are obtained in the following ways:

a. by normal convection

The heat is produced by the upper and lower heating elements.

b. by forced convection

A fan sucks in the air contained in the oven, which circulates it through the circular heating element and then forced back into the oven by the fan. Before the hot air is sucked back again by the fan to repeat the described cycle, it envelops the food in the oven, provoking a complete and rapid cooking. It is possible to cook several dishes simultaneously.

c. by semi-forced convection

The heat produced by the upper and lower heating elements is distributed throughout the oven by the fan.

d. by radiation

The heat is radiated by the infra red grill element.

e. by radiation and ventilation

The radiated heat from the infra red grill element is distributed throughout the oven by the fan.

f. by ventilation

The food is defrosted by using the fan only function without heat.

Attention: the oven door becomes very hot during operation. Keep children away.

THERMOSTAT KNOB (fig. 2.1)

To turn on the heating elements of the oven, set function selector knob to the required position and the thermostat knob to the desired temperature.

To set the temperature, turn the thermostat control knob indicator mark to the required temperature.

The elements will turn on or off automatically which is determined by the thermostat.

The operation of the heating elements is signalled by a light placed on the control panel.

FUNCTION SELECTOR KNOB (fig. 2.2)

Rotate the knob clockwise to set the oven to one of the following functions:



By turning the function selector knob to this setting, the oven light will illuminate in the oven cavity.

The oven light will operate on all selected functions.



The upper and lower heating elements are switched on.

The heat is diffused by natural convection and the temperature must be regulated between 50°C and the maximum position with the thermostat knob.

It is necessary to preheat the oven before introducing the foods to be cooked.

Recommended for:

For foods which require the same cooking temperature both internally and externally, i. e. roasts, spare ribs, meringue, etc.

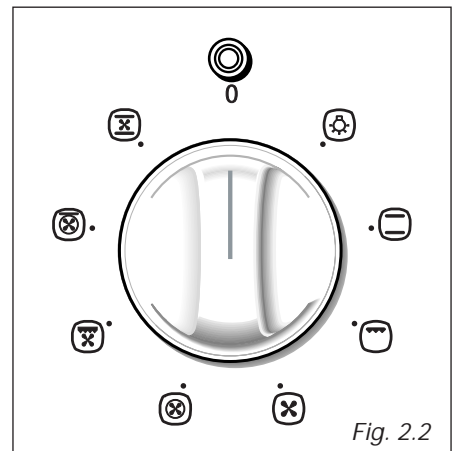
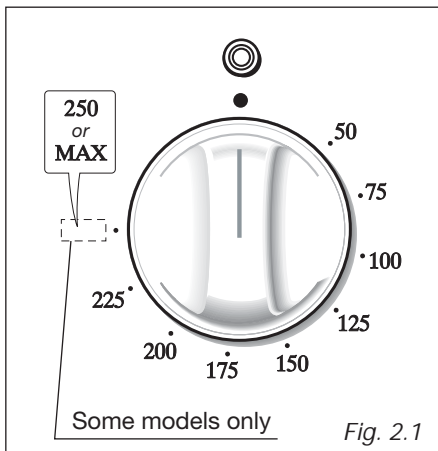



GRILLING

The infra-red heating element is switched on. The heat is diffused by radiation.

Use with the oven door **closed** and the thermostat knob must be regulated between **50°C** and **200°C max**.

For correct use see chapter "USE OF THE GRILL".

Recommended for:

Intense grilling action for cooking with the broiler; browning, crisping, "au gratin", toasting, etc.



HOT AIR COOKING

The circular element and the fan are on. The heat is diffused by forced convection and the temperature must be regulated between 50°C and the maximum position with the thermostat knob.

It is not necessary to preheat the oven.

Recommended for:

For foods that must be well done on the outside and tender or rare on the inside, i. e. lasagna, lamb, roast beef, whole fish, etc.



DEFROSTING FROZEN FOODS

Only the oven fan is on.

To be used with the thermostat knob in the off "●" position because the other positions have no effect.

The defrosting is done by simple ventilation without heat.

Recommended for:

To rapidly defrost frozen foods; 1 kilogram requires about one hour.

The defrosting times vary according to the quantity and type of foods to be defrosted.



VENTILATED GRILL COOKING

The infra-red grill and the fan are on.

The heat is mainly diffused by radiation and the fan then distributes it throughout the oven.

The temperature must be regulated between **50°C** and **200°C max** with the thermostat knob.

It is necessary to preheat the oven for about 5 minutes.

For correct use see chapter "GRILLING AND AU GRATIN".

Always grill with the oven door closed.

Recommended for:

For grill cooking when a fast outside browning is necessary to keep the juices in, i. e. veal steak, steak, hamburger, etc.



MAINTAINING TEMPERATURE AFTER COOKING OR SLOWLY HEATING FOODS

The upper element and the circular element connected in series, are switched on; also the fan is on.

The heat is diffused by forced convection with the most part being produced by the upper element.

The temperature must be regulated between 50° and 140 °C with the thermostat knob.

Recommended for:

To keep foods hot after cooking.

To slowly heat already cooked foods.



CONVECTION COOKING WITH VENTILATION

The upper and lower heating elements and the fan turn on.

The heat coming from the top and bottom is diffused by forced convection.

The temperature must be regulated between 50°C and the maximum position with the thermostat knob.

Recommended for:

For foods of large volume and quantity which require the same internal and external degree of cooking; for example: rolled roasts, turkey, legs, cakes, etc.

COOKING ADVICE

STERILIZATION

Sterilization of foods to be conserved, in full and hermetically sealed jars, is done in the following way:

- Set the switch to position
- Set the thermostat knob to position 185 °C and preheat the oven.
- Fill the grill pan with hot water.
- Set the jars into the grill pan making sure they do not touch each other and the door and set the thermostat knob to position 135 °C.

When sterilization has begun, that is, when the contents of the jars start to bubble, turn off the oven and let cool.

REGENERATION

Set the switch to position

and the thermostat knob to position 150° C. Bread becomes fragrant again if wet with a few drops of water and put into the oven for about 10 minutes.

ROASTING

To obtain classical roasting, it is necessary to remember:

- that it is advisable to maintain a temperature between 180 and 200 °C.
- that the cooking time depends on the quantity and the type of foods.

The external parts of the oven become hot during operation. Keep children well out of reach.

COOKING DIFFERENT DISHES AT THE SAME TIME

With the function selector in position , the ventilated oven allows you to cook different types of food at the same time.

Fish, cakes and meat can be cooked together without the smells and flavours mixing.

The only precautions required are the following:

- The cooking temperatures must be as close as possible with a maximum difference of 20° - 25°C between the different foods.
- Different dishes must be placed in the oven at different times according to the cooking time required for each one. This type of cooking obviously provides a considerable saving on time and energy.

GRILLING AND "AU GRATIN"

Grilling may be done by selecting grill+fan setting  with the function selector knob, because the hot air completely envelops the food that is to be cooked.

Set the thermostat knob **between 50°C and 200°C max** and after having pre-heated the oven, simply place the food on the grid.

Close the door and let the oven operate until grilling is done.

Adding a few dabs of butter before the end of the cooking time gives the golden "au gratin" effect.

Grilling with the oven door closed.

It is recommended that you do not grill for longer than 30 minutes at any one time.

Attention: the oven door becomes very hot during operation.

Keep children away.

USE OF THE GRILL

Set the function selector knob to position  and the thermostat knob **between 50°C and 200°C max.**

Leave to warm up for approximately 5 minutes with the door **closed.**

Introduce the food to be cooked, positioning the grill pan as close to the grill as possible.

Always grill with the oven door closed.

Grilling with the oven door closed and not for longer than 30 minutes at any one time.

Attention: the oven door becomes very hot during operation.

Keep children away.

Clock and timer with "Touch-Control" keys 3

Keys:	
+ and - or ▲ and ▼ or other equivalent symbols	Touched simultaneously (for more than 2 seconds): <ul style="list-style-type: none"> • setting the clock; • setting the timer volume (by touching once, along with the "MODE" key); • to cancel automatic cooking at any time.
MODE or other equivalent wording / symbol	Function selection (touched for more than 2 seconds): <ul style="list-style-type: none"> • setting the clock (only after first connection or after a power failure); • timer; • automatic cooking "dur" (duration) - how long the food will take to cook (by touching the "MODE" key again); • automatic cooking "End" - the time you would like the oven turns off (by touching the "MODE" key two more times);
+ or ▲ or other equivalent symbol	Increases the number shown on the display
- or ▼ or other equivalent symbol	Decreases the number shown on the display

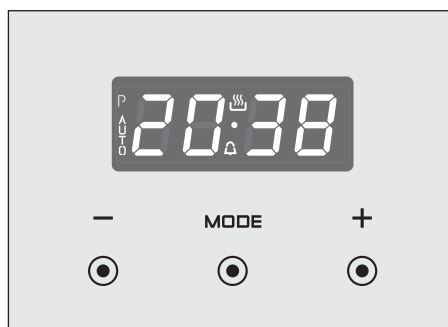

Fig. 3.1

Illuminated symbols:		
AUTO	<i>flashing</i>	Automatic cooking completed, oven in automatic position but not set
AUTO	<i>steady illumination</i>	Oven set for automatic cooking, cooking still not taking place
	<i>flashing</i>	Timer being set
	<i>steady illumination</i>	Timer in operation
	<i>steady illumination</i>	Oven set for manual cooking
and AUTO	<i>AUTO flashing</i>	Automatic cooking being set
and AUTO	<i>steady illumination</i>	Oven set for automatic cooking, cooking taking place

“TOUCH-CONTROL” KEYS

The “touch-control” keys shall be operated by the fingers (just by touching the key). When using touch controls it is best to use the ball of your finger rather than the tip.

The keys are automatically deactivated:

- 8 seconds after the last selection; the deactivation is indicated by an acoustic signal (“beep”).

To reactivate just touch the “**MODE**” key or the “+” and “-” keys (simultaneously) for more than 2 seconds.

SETTING THE CLOCK

When first connected, or after a power failure, the digits and “**AUTO**” will shown on the display. To set the clock, touch the “**MODE**” key, for more than 2 seconds, and then the “+” or “-” keys.

Important: the oven does not operate, in manual cooking, without first having set the clock.

To set the clock, with the appliance already connected, touch the “+” and “-” keys simultaneously (for more than 2 seconds), then “+” or “-” keys.

Important:



- changing the time will delete any automatic program;
- after setting the clock, the oven starts to operate in the selected function (manual cooking). The “” symbol is steady illuminated.

USING THE TIMER

You can use the timer at any time, even when the oven is not in use.

The timer does not turn the oven off.

The timer can be set for up to 23 hours and 59 minutes.

- To set the timer, touch the “**MODE**” key for more than 2 seconds (the “” symbol flashes), than the “+” or “-” keys.
- After about 8 seconds an acoustic signal (“beep”) will sound confirming the regulation (“” symbol steady illuminated).
- To check the remaining time touch the “**MODE**” key for more than 2 seconds. If the remaining time is more than a minute the display will show hours and minutes; if less than a minute the display will show seconds.
- When the time is up, the timer will beep. Touch the “**MODE**” key , for more then 2 seconds, to turn it off; or press the “+” or “-” key to stop the beep and than the “**MODE**” key, for more than 2 seconds, to deactivate the “” symbol flashing on the display.
- Turn off the oven manually (function and thermostat knobs in the off position) if the manual cooking has been completed.

SETTING THE TIMER VOLUME

You can select from three volume levels.

- Touch the “+” and “-” keys simultaneously for more than 2 seconds.
- Touch the “MODE” key; you can read on the display the current timer volume (“*ton1*”, “*ton2*” or “*ton3*”).
- Touch the “-” key to listen or change the timer volume.
- Timer volume activated: the last displayed.
- After about 8 seconds an acoustic signal (“beep”) will sound confirming the volume setting; then the time of day will be displayed.

AUTOMATIC COOKING

Use automatic cooking to automatically turn the oven on, cook, and then turn the oven off.

1. Check the clock shows the correct time.
2. Select the function and temperature (function and temperature knobs). The oven will come on.
3. Decide how long the food will take to cook, allowing time for preheating if necessary.
4. Touch the “MODE” key for more than 2 seconds and then touch again. “*dur*” will show (duration). Using the “+” and “-” keys, set the cooking time.
5. Decide the time you would like the oven to turn off; touch the “MODE” key for more than 2 seconds and then touch it two times again. “*End*” will show. Using the “+” and “-” keys, set the cooking time.

Note: while “*dur*” is displayed you can change to “*End*” just by touching one time the “MODE” key (within 8 seconds from the last selection).

If there is time to wait before cooking starts, the current time of day and “**AUTO**” will show in the clock display. The oven will switch off but is now set for automatic cooking.

If you are already at home to turn the oven on and only want the oven to turn off automatically, start cooking as normal, then follow step 4 or step 5 to set a time to stop the oven.

When automatic cooking starts, “” will be displayed and the oven will turn on.

- To see the remaining cook time, follow step 4 up to display “*dur*” (duration).
- To see the set stop time, follow step 5 up to display “*End*”.
- To cancel automatic cooking at any time, touch the “+” and “-” keys simultaneously (for more than 2 seconds) and turn the temperature and function knobs to the off position.

When the stop time is reached, the oven will turn off, the timer will beep and “**AUTO**” will flash:









- Touch any key to stop the beeping.
- Touch the “MODE” key, for more than 2 seconds, to return the oven to the manual mode (“” symbol steady illuminated on the display).
- Turn the temperature and function knobs to the off position.

Attention: after a power failure any automatic program is deleted. Turn off the oven manually.

The electronic programmer is a device which groups together the following functions:

- 24 hours clock with illuminated display
- Timer (up to 23 hours and 59 minutes)
- Program for automatic oven cooking
- Program for semi-automatic oven cooking.

Description of the buttons:

-  Timer
-  Cooking time
-  End of cooking time
-  Manual position and cancellation of the inserted cooking program
-  or  To increase the numbers on the digital display
-  or  To decrease the numbers on the digital display.

Description of the illuminated symbols:

AUTO - *flashing* - Programmer in automatic position but not programmed

AUTO - *illuminated* - Programmer in automatic position with program inserted.





 Automatic cooking taking place

 Timer in operation

 and **AUTO** - *flashing* - Program error.

(The time of day lies between the calculated cooking start and end time).

Note:

Select a function by the respective button and, in 5 seconds, set the required time with the  () /  () buttons ("one-hand" operation).

After a power cut the display resets to zero and cancels the set programs.

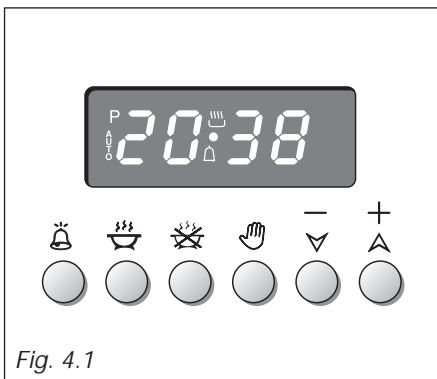

Fig. 4.1

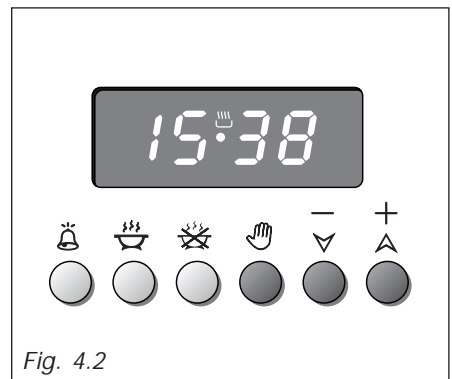









Fig. 4.2

ELECTRONIC CLOCK (fig. 4.2)

The programmer is equipped with an electronic clock with illuminated numbers which indicates hours and minutes.



Upon immediate connection of the oven or after a power cut, three zeros will flash on the programmer display.

To set the correct time of day it is necessary to push the  button and then the  (\oplus) or  (\ominus) button until you have set the correct time (fig. 4.2).

In another way push simultaneously the   two buttons and at the same time push the  (\oplus) or  (\ominus) button.

Note: If the clock is reset it deletes any previously set programs.

NORMAL COOKING WITHOUT THE USE OF THE PROGRAMMER

To manually use the oven, without the aid of the programmer, it is necessary to cancel the flashing **AUTO** by pushing the button  (**AUTO** will be switched off and the symbol  will illuminate - Fig. 4.3).





Attention: If the **AUTO** is illuminated (which means a cooking program has already been inserted), by pushing the button  you cancel the program and return to manual operation.

If the oven is switch on, you must switch off manually.



ELECTRONIC TIMER

The timer program consists only of a buzzer which may be set for a maximum period of 23 hours and 59 minutes.

If the **AUTO** symbol is flashing push the  button.

To set the time, push the  button and the  (\oplus) or  (\ominus) until you obtain the desired time in the panel (fig. 4.4). Having finished the setting, the clock hour will appear on the panel and the  symbol will be illuminated.

The countdown will start immediately and may be seen at any moment on the panel by simply pressing the button .

At the end of the time, the  symbol will disappear and the buzzer will sound and continue for approximately 7 minutes or until a button is pressed (not the  (\oplus) /  (\ominus) buttons).

After a short time the display will revert back to the time of day.

SETTING THE FREQUENCY OF THE AUDIBLE SIGNAL

The buzzer has 3 different tones and can be changed by pressing the  (\ominus) button, but only when the time of day is displayed

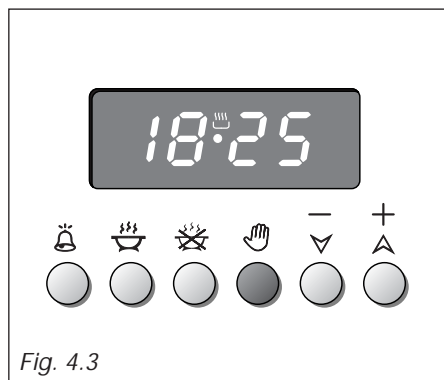

Fig. 4.3

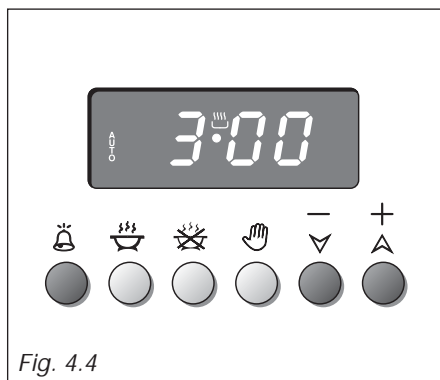









Fig. 4.4

AUTOMATIC OVEN COOKING

To cook food automatically in the oven, it is necessary to:

1. Set the length of the cooking period
2. Set the end of the cooking time
3. Set the temperature and the oven cooking program.

These operations are done in the following way:

1. Set the length of the cooking period by pushing the  button and the  (+) button to increase, or  (-) to decrease if you have passed the desired time (fig. 4.5). The **AUTO** and the  symbol will illuminate.
2. Set the end of the cooking time by pressing the  button (the cooking time already added to the clock time will appear), and the  (+) button (fig. 4.6); if you pass the desired time you may get back by pushing the  (-) button.

After this setting, the  symbol will disappear. If after this setting, the **AUTO** flashes on the display and a buzzer sounds, it means there was an error in the programming, that is that the cooking cycle has been superimposed on the clock.

In this case, modify the end of cooking time or the cooking period itself by following again the above mentioned instructions.



3. Set the temperature and the cooking program by using the switch and thermostat knobs of the oven (see specific chapters).

Now the oven is programmed and everything will work automatically, that is the oven will turn on at the right moment to end the cooking at the established hour.

During cooking, the  symbol remains illuminated.

By pushing the  button you can see the time that remains until the end of cooking.

The cooking program may be cancelled at any time by pushing .

At the end of the cooking time the oven will turn off automatically, the  symbol will turn off, **AUTO** will flash and a buzzer will be sound, which can be turned off by pushing any of the buttons except the  (+) /  (-) buttons.

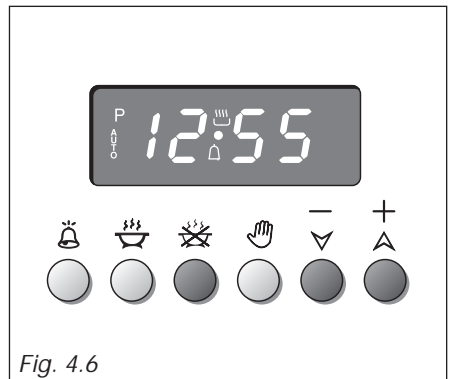
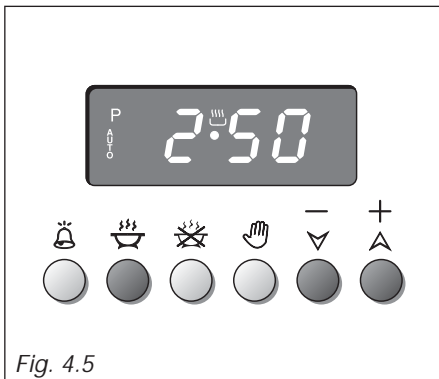

Turn the switch and thermostat knobs to zero and put the programmer onto "manual" by pressing the  button.

Attention: After a power cut the clock resets to zero and cancels the set programs. After a power cut, three zeros will flash on the display.



SEMI - AUTOMATIC COOKING



This is used to automatically switch off the oven after the desired cooking period has elapsed.

Set the length of the cooking period by pushing the  button and the  (+) button to increase, or  (-) to decrease if you have passed the desired time (fig. 4.7).



AUTO and the  symbol will be illuminated.

Then set the temperature and the cooking program using the function selector switch and thermostat knobs (see specific chapters).

The oven is switched on and it will be switched off automatically at the end of the desired time.

During cooking, the  symbol remains illuminated and by pressing the button  you can see the remaining cooking time.

The cooking program can be cancelled at any time by pushing the  button.

At the end of the cooking period, the oven and the  symbol will disappear, **AUTO** will flash and a buzzer will sound and can be stopped by pushing any of the buttons except the  (+) /  (-) buttons.



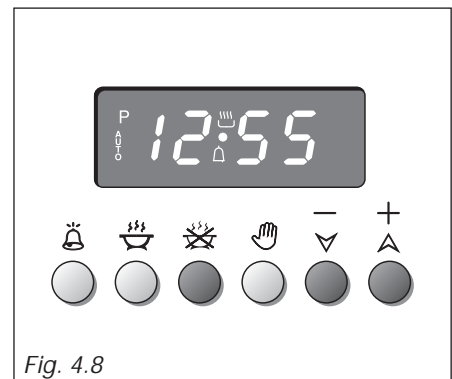
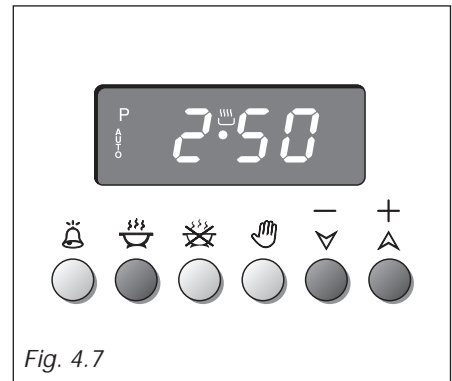

Turn the function selector switch and thermostat knobs to zero and put the programmer onto "manual" by pressing the  button.





The electronic clock/programmer performs the following functions ("one-hand" operation):

- 12 hours clock with luminous hands (hours, minutes and seconds).
- Timer (up to 60 minutes).
- Automatic cooking program. The oven starts to operate at the programmer time (within 12 hours when the oven is programmed) and automatically switches off at the end of the programmed required time (max 6 hours).
- Semi-automatic cooking program. The oven automatically switches off at the end of the programmed cooking time (max 6 hours).

Buttons description:

-  Timer
-  Cooking time/End of cooking time (hour)
-  Clock setting/Cancelling a set program
-  To increase (clockwise rotation of the clock/programmer hands)
-  To decrease (anti-clockwise rotation of the clock/programmer hands)

Note: To set the clock/programmer ("one-hand operation") press the relative function button and then, within 7 seconds, press the  or  buttons.

After a power cut (black out) the display resets to zero and cancels the set programs.

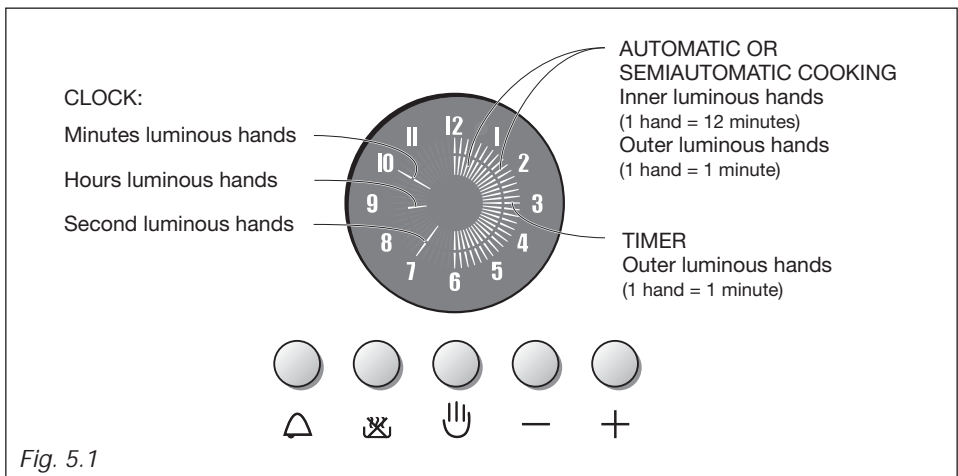

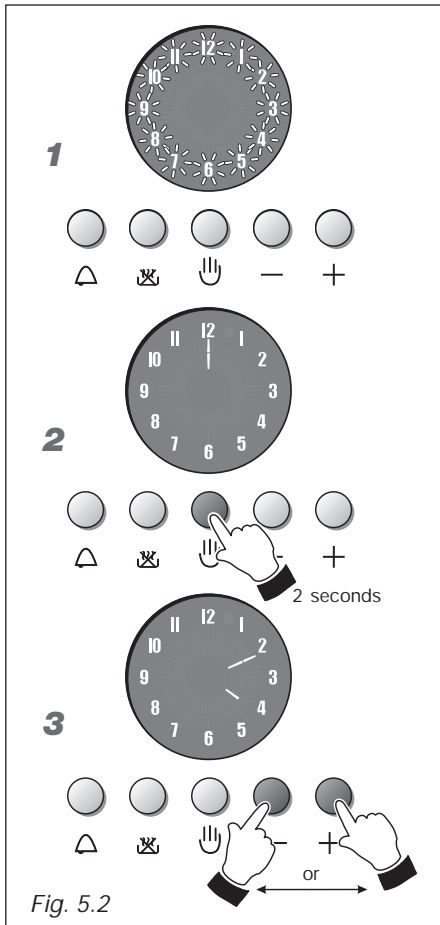

Fig. 5.1

CLOCK (fig. 5.2)



1. Fig. 5.2 - Upon immediate connection of the oven or after a power cut (black out), the numbers on the programmer display will flash.
2. Fig. 5.2 - To set the time, press button  for about one second; one hand appears on 12.
3. Fig. 5.2 - Within 7 seconds press \oplus or \ominus buttons to set the time of the day (hours and minutes). Seven seconds after the last selection, the seconds hand appears on the display.

Note: If the clock is reset it deletes any previously set program.



MANUAL COOKING WITHOUT PROGRAMMER (fig. 5.3)

To manually use the oven, without the programmer, the numbers on the display do not have to flash and the inner hands do not have to be lit (none semi-automatic or automatic program set).

- A. Fig. 5.3 - Programmer with a set program. To cancel the set program press button  for about 2 seconds; inner hands disappears on the display and the oven can be used in manual mode.
- B. Fig. 5.3 - Flashing numbers on the display (normally after turning off the buzzer which indicates the end of a programmed cooking). Press  button. The numbers stop flashing and the oven can be used in manual mode.

Attention: At the end of the cooking switch off the oven manually by turning the function and temperature control knobs to the "0" (OFF) position.

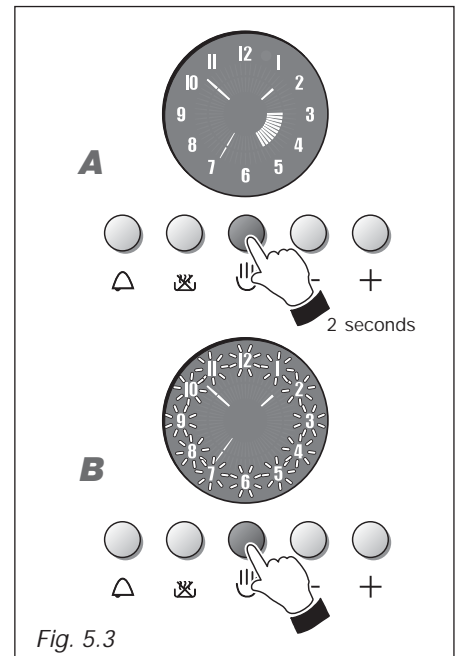

TIMER (fig. 5.4)

The timer program consists only of a buzzer which may be set for a maximum period of 60 minutes.

1. Fig. 5.4 - To set the timer program press \triangle button.
2. Fig. 5.4 - Press button \oplus within 7 seconds and set the required time. Outer luminous hands light up. Press button \ominus to decrease the time.
3. Fig. 5.4 - The countdown starts immediately and an anti-clockwise luminous hand lights up on the display. On each rotation (1 minute) of this hand one outer luminous hand goes out.

During the countdown it is possible, at any time, to change the setting by pressing button \oplus or \ominus ; to reset the timer press button \ominus until reaching zero minutes (none outer luminous hand lit).

At the end of the time, the last outer luminous hand goes out and the buzzer sounds. To stop the buzzer press any of the clock/programmer buttons. The display shows the time of the day.

To display the time of the day during the countdown, press button \triangle (fig. 5.5); to display the countdown again press button \triangle .

Note: the timer can be set also if a semi-automatic or automatic cooking program is operating.

ATTENTION: The timer do not switches off the oven at the end of the countdown. Remember to switch off the oven manually by turning the function and temperature control knobs the "0" (OFF) position.

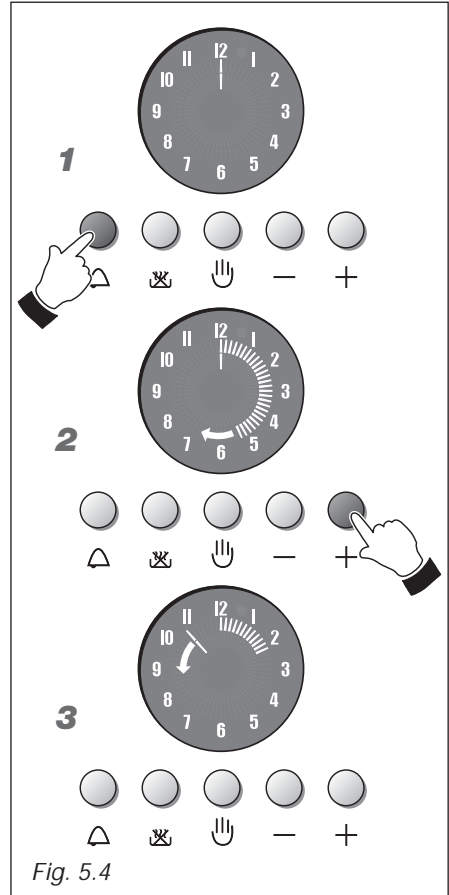

Fig. 5.4

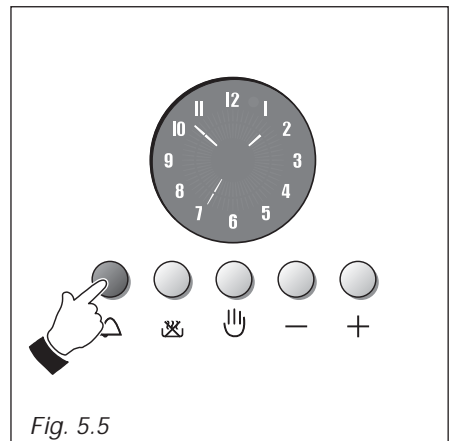







Fig. 5.5

SEMI-AUTOMATIC COOKING (fig. 5.6)

This function automatically switches off the oven after the required cooking time.

1. Fig. 5.6 - To set the cooking time (max 6 hours) press button , the electronic clock luminous hands go out and a luminous hand lights up on number 12.
2. Fig. 5.6 - Within 7 seconds press  button and another luminous hand (like seconds and minutes) lights up on the display. Every increasing (additional inner hand) indicates one minute. Moreover every increasing of the 12 minutes is indicated by an inner luminous hand (5 luminous hands indicate one hour). To decrease the required time press  button.
3. Fig. 5.6 - After 7 seconds the inner luminous hands turn automatically on the time of the day indicating the remaining cooking time.
4. Set the oven by turning the function and the temperature control knobs to the required function and temperature (see relative chapters). The oven starts to operate immediately and is automatically turned off at the end of the programmed cooking time.

During cooking the inner luminous hands flash on the display indicating that the oven is operating. The inner luminous hands gradually go out (one each 12 minutes).

During the cooking program it is possible, at any time, to modify the cooking time by pressing first  button and then  or .

At the end of the programmed cooking time the last inner luminous hand goes out and the oven automatically switches off; the numbers on the programmer display flash and a buzzer sounds.

To stop the buzzer press any of the clock/programmer buttons.

To stop the flashing of the numbers of the clock press  button.

The semi-automatic cooking program can be cancelled at any time by pressing button  for 2 seconds.

ATTENTION: At the end of the semi-automatic cooking remember to switch off the oven manually by turning the function and temperature control knobs the "0" (OFF) position.

Attention: After a power cut (black out) the clock/programmer resets to zero and cancels the set programs (numbers of the clock flashing on the display without luminous hands - fig. 5.9).

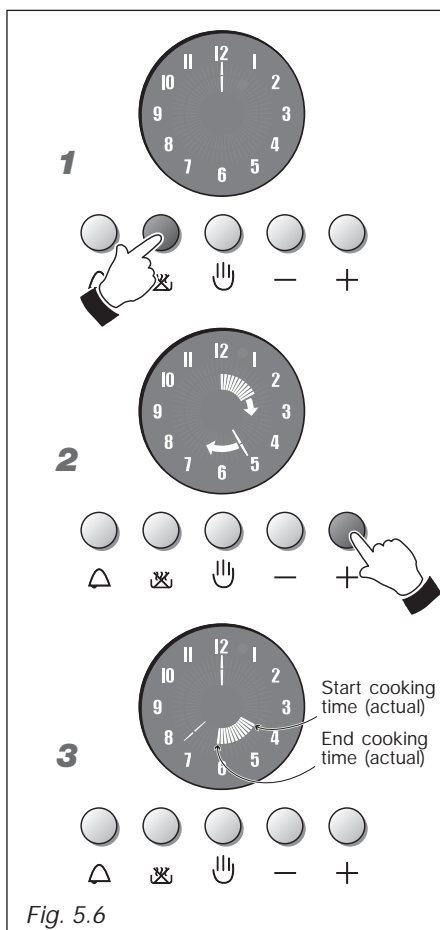







Fig. 5.6

AUTOMATIC COOKING (fig. 5.7)

This function automatically switches on the oven and switches it off at the required time. To cook the food in the automatic mode follow these instructions:

- Set the duration of the cooking (max 6 hours)
- Set the time when cooking has to be completed (within 12 hours from when the cooking is programmed)
- Set the cooking temperature and function.

For the automatic cooking operate in the following way:

1. Fig. 5.7 - To set the cooking time (max 6 hours) press button , the electronic clock luminous hands go out and a luminous hand lights up on number 12.
2. Fig. 5.7 - Within 7 seconds press  button and another luminous hand (like seconds and minutes) lights up on the display. Every increasing (additional inner hand) indicates one minute. Moreover every increasing of the 12 minutes is indicated by an inner luminous hand (5 luminous hands indicate one hour). To decrease the required time press  button.
3. Fig. 5.7 - Within 7 seconds press another time  button; the inner luminous hands turn automatically on the time of the day.
4. Fig. 5.7 - Within 7 seconds press  button and position (by pressing the button) the inner luminous hands on the hour when the oven has to start the cooking program. Press button  to decrease.
5. Fig. 5.7 - After 7 seconds the clock luminous hands appear again on the display and the inner luminous hands indicate the programmed cooking time.
6. Set the oven by turning the function and the temperature control knobs to the required function and temperature (see relative chapters). Now the oven is programmed and it starts and stops to operate automatically, conforming to the automatic cooking program.

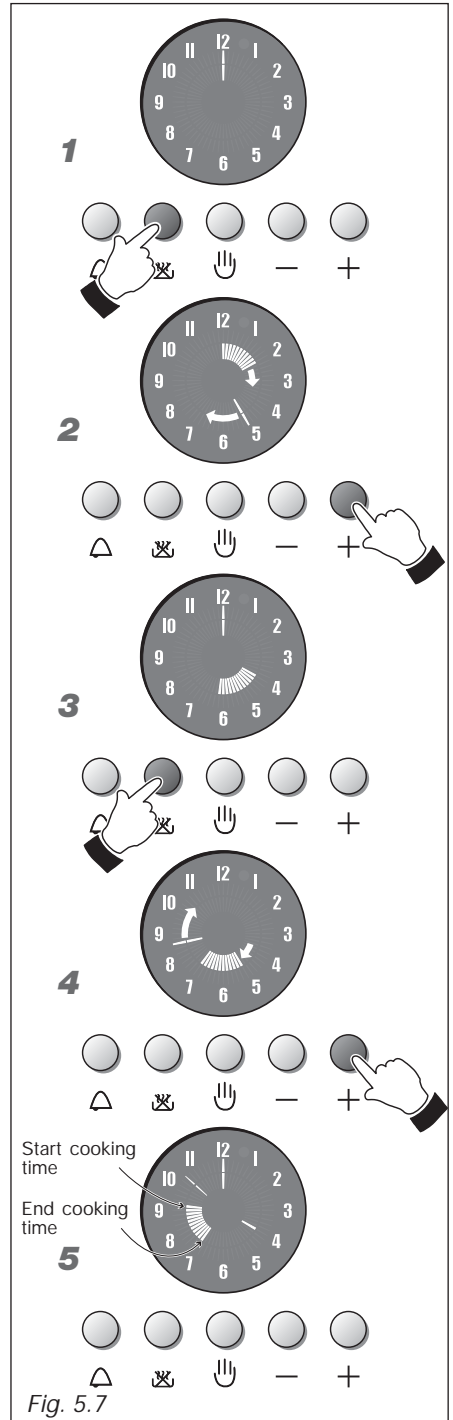





Fig. 5.7

When the oven starts the cooking program the inner luminous hands are flashing on the display indicating that the oven is operating and they gradually go out (one each 12 minutes).

During the cooking program it is possible, at any time, to modify the cooking time by pressing first  button and then  or .

At the end of the programmed cooking time the last inner luminous hand goes out and the oven automatically switches off; the numbers on the programmer display flash and a buzzer sounds.

To stop the buzzer press any of the clock/programmer buttons.

To stop the flashing of the numbers of the clock press  button.

The automatic cooking program can be cancelled at any time by pressing  button for 2 seconds.

ATTENTION: At the end of the automatic cooking remember to switch off the oven manually by turning the function and temperature control knobs the "0" (OFF) position.

Attention: After a power cut (black out) the clock/programmer resets to zero and cancels the set programs (numbers of the clock flashing on the display without luminous hands - fig. 5.9).

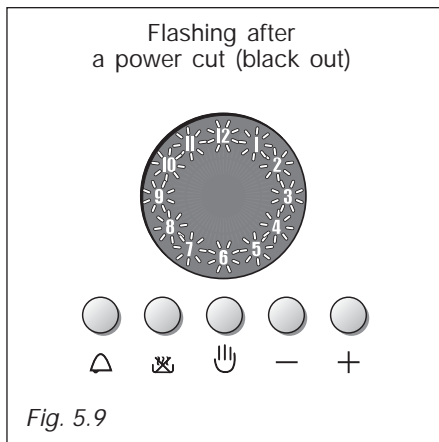
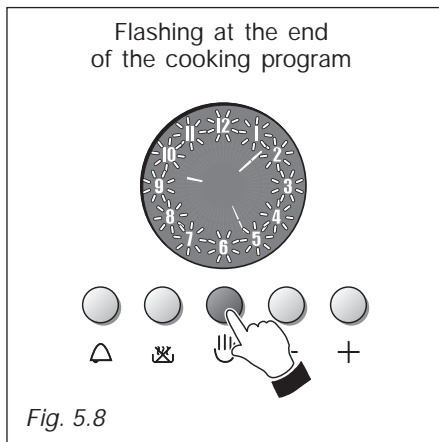



Electronic clock/end cooking timer 6a

The electronic programmer is a device with the following functions:

- 24 hours clock with illuminated display
- Timing of oven cooking with automatic switch-off (max. 99 minutes).

ELECTRONIC CLOCK

Upon immediate connection of the oven or after a mains failure, three zeros will flash on the programmer panel.

To set the clock it is necessary to push the  button and then, within 7 seconds, the  or  button until you have set the correct time.

The clock will show zero after a mains failure.

Attention: When the programmer display shows three flashing zeros the oven cannot be switched on.





The oven can be switched on when the symbol  is shown in the display.

SETTING THE FREQUENCY OF THE ALARM SOUND



The selection from 3 possibilities of sound can be made by pressing the  button.

COOKING WITH AUTOMATIC SWITCH-OFF

The aim of this function is to automatically stop the cooking after a pre programmed time, for a maximum period of 99 minutes.



To set the cooking time, push the  or  button until you obtain the desired time in the display. The symbol AUTO will be shown in the display. Then you adjust the oven thermostat knob according to the required temperature. The oven will immediately start to operate and will work for the pre programmed time. The display shows the count down. Clock time can be displayed by pressing the  button. Once the time has elapsed, the oven will switch off automatically, the symbol AUTO will go off and an intermittent buzzer, lasting 7 minutes, will start; this can be stopped by pressing the .

Important: Before the buzzer is stopped switch off the oven manually.

To cancel the cooking program at any time press the  and  buttons together and release the  button first.

ELECTRONIC ALARM

The programmer can be used as an alarm only for a maximum period of 99 minutes.

To set the alarm, push the  or  button until you obtain the desired time in the display. Once the time has elapsed, an intermittent buzzer, lasting 7 minutes, will start; this can be stopped by pressing the .

Attention: If the bottom oven is switched on when the buzzer starts, it will be automatically switched off. For it to operate furtherly you have to stop the buzzer by pressing the .

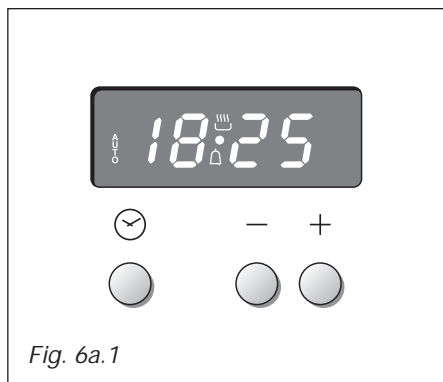





Fig. 6a.1

ELECTRONIC CLOCK (fig. 6b.1)

The electronic alarm is a device which groups the functions of 24 hours clock with illuminated display and 99 minutes alarm.





Upon immediate connection of the oven or after a blackout, three zeros will flash on the programmer panel.



To set the hour it is necessary to push the  button and then, within 7 seconds, the  or  button until you have set the exact hour.

An energy black-out makes the clock go to zero.

ELECTRONIC ALARM

The alarm program consists only of a buzzer which may be set for a maximum period of 99 minutes.

To set the time, push the  or  until you obtain the desired time in the panel. Having finished the setting, the  symbol will be lighted and the countdown will start immediately. At the end of the time, the  symbol will be switched off and an intermittent buzzer, during 7 minutes, will go off; this can be stopped by pressing the  buttons.

To stop the alarm countdown in any moment press the  and  buttons together and release the  button first.

SETTING THE FREQUENCY OF THE ALARM SOUND

The selection from 3 possibilities of sound can be made by pressing the  button.

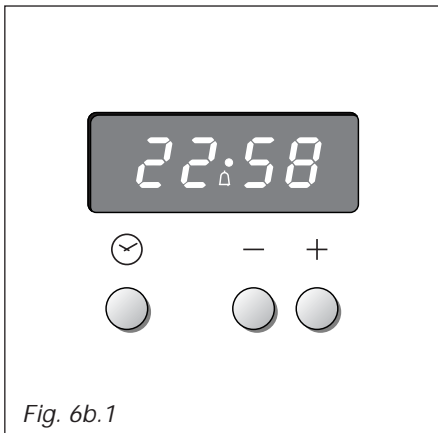

Fig. 6b.1

The clock programmer is a device which groups together the following functions:

- Electric clock.
- Timing of oven cooking with automatic switch-off (max. 180 minutes).
- End cooking buzzer.

SETTING THE TIME

To adjust, simply press the knob "A" (fig. 7.1) and rotate anticlockwise to the correct time.

MANUAL COOKING (without programmer)

To use the oven without the programmer, i.e. only with the function selector/thermostat, the programmer function must be cancelled by rotating knob "A" anticlockwise until the symbol  in window "B" coincides with the indicator (fig. 7.1).

COOKING WITH AUTOMATIC SWITCH-OFF

- Turn on the oven by setting the switch knob on the desired program and the thermostat knob onto the desired temperature (see specific chapters).
- Set the cooking time by rotating knob "A" anticlockwise until desired time in window "B" coincides with the indicator (fig. 7.2).

The oven will immediately start to operate and will work for the pre programmed time.

Once the time has elapsed, the oven will switch off automatically and an intermittent buzzer will start; this can be stopped by rotating knob "A" until the symbol  in window "B" coincides with the indicator (fig. 7.3).

Turn the switch and thermostat knobs to "off" position.

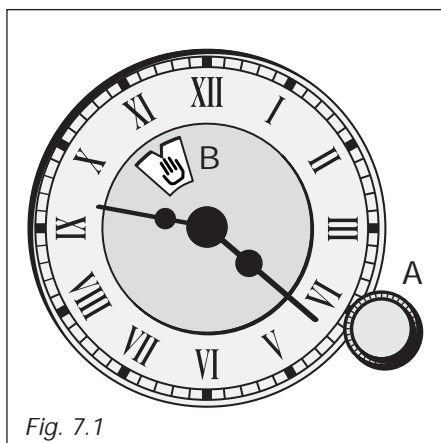

Fig. 7.1

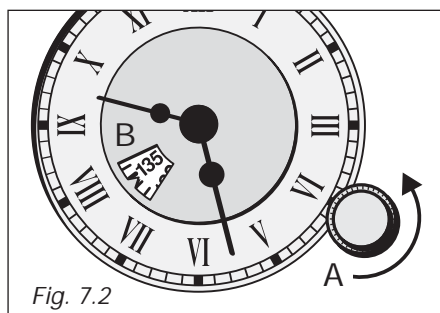

Fig. 7.2

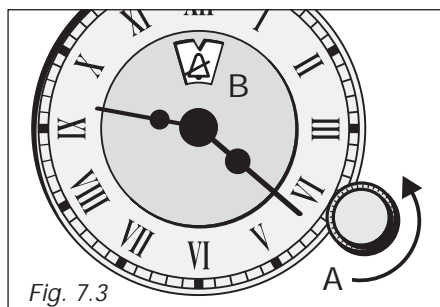

Fig. 7.3

Electric clock with alarm - Electric clock 8

ELECTRIC CLOCK WITH ALARM

(fig. 8.1)

To adjust the clock, press knob "A" and turn clockwise until it shows the correct time.

Caution: the knob "A" will become loose if turned anticlockwise.

MINUTE COUNTER

The minute counter function consists simply of an acoustic signal which comes on once the set time has elapsed.

To set the minute counter, rotate the small knob (A) clockwise or anticlockwise (without pressing it) until the hand (C) coincides with the required time (max 55 minutes) (fig. 8.1).

Countdown will begin immediately and the hand (C) will begin to turn anticlockwise, always showing the remaining time.

Once the set time has elapsed the bell will ring until the hand (C) is positioned to the symbol  by rotating the knob (A) anticlockwise.

ELECTRIC CLOCK (fig. 8.2)

To adjust the clock, press knob "A" and turn clockwise until it shows the correct time.

Caution: the knob "A" will become loose if turned anticlockwise.

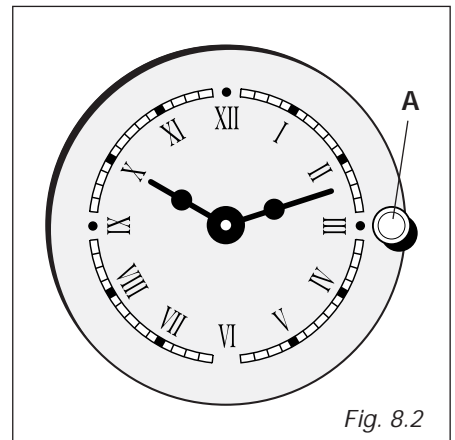
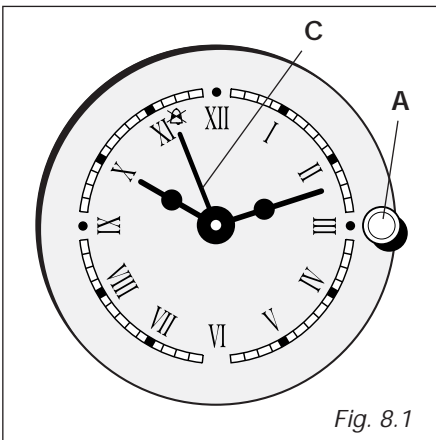

TIMER - 120' CUT-OFF (fig. 9.1)

The function of the timer runs the oven for a preset time.

1) Starting up.

After setting the function selector and thermostat to the required mode and temperature, rotate the timer knob clockwise until you reach the required cooking time (max 120 minutes). Once this time has elapsed, the timer will return to the "0" position and the oven will automatically switch off.

2) Manual position.

If the cooking time is longer than two hours or if you wish to use the oven manually, switching it off as required, the knob must be turned to position .

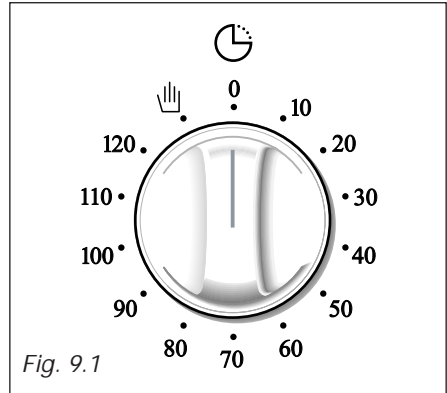

Fig. 9.1

60' ALARM (fig. 9.2)

The minute counter is a timed acoustic warning device which can be set for a maximum of 60 minutes.

The knob must be rotated clockwise as far as the 60 minute position and then set to the required time by rotating it anticlockwise.

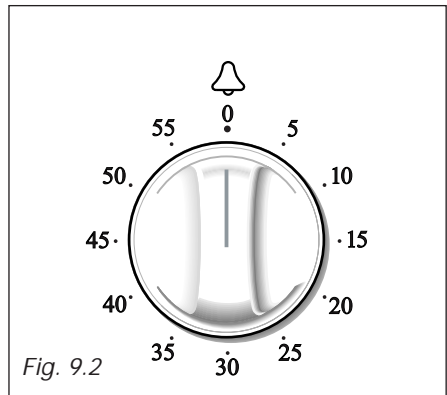

Fig. 9.2

120' ALARM (fig. 9.3)

The minute counter is a timed acoustic warning device which can be set for a maximum of 120 minutes.

The knob must be rotated clockwise as far as the 120 minute position and then set to the required time by rotating it anticlockwise.

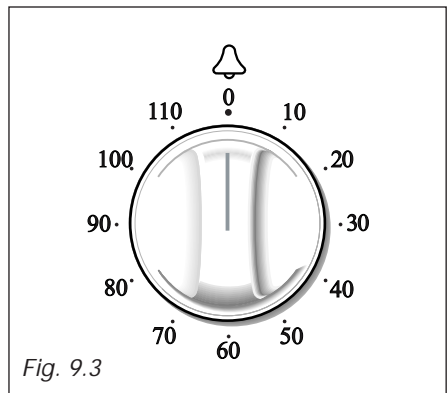

Fig. 9.3

GENERAL ADVICE

Important:

Before any operation of cleaning and maintenance disconnect the appliance from the electrical supply.

It is advisable to clean when the appliance is cold and especially for cleaning the enamelled parts.

Avoid leaving alkaline or acidic substances (lemon juice, vinegar, etc.) on the surfaces. Avoid using cleaning products with a chlorine or acidic base.

WARNING

When correctly installed, your product meets all safety requirements laid down for this type of product category. However special care should be taken around the rear or the underneath of the appliance as these areas are not designed or intended to be touched and may contain sharp or rough edges, that may cause injury.

INSIDE OF OVEN

The oven should always be cleaned after use when it has cooled down.

The cavity should be cleaned using a mild detergent solution and warm water.

Suitable proprietary chemical cleaners may be used after first consulting with the manufacturers recommendations and testing a small sample of the oven cavity.

Abrasive cleaning agents or scouring pads/cloths should not be used on the cavity surface.

NOTE: The manufacturers of this appliance will accept no responsibility for damage caused by chemical or abrasive cleaning.

Let the oven cool down and pay special attention no to touch the hot heating elements inside the oven cavity.

Do not use a steam cleaner because the moisture can get into the appliance thus make it unsafe.

Do not store flammable material in the oven.

ENAMELLED PARTS

All the enamelled parts must be cleaned with a sponge and soapy water only or other non-abrasive products.

Dry preferably with a microfibre or soft cloth.

STAINLESS STEEL SURFACES (MODELS WITHOUT ANTI-FINGERPRINT TREATMENT), ALUMINIUM PARTS AND PAINTED OR SILK-SCREEN PRINTED SURFACES

Clean using an appropriate product. Always dry thoroughly.

IMPORTANT: these parts must be cleaned very carefully to avoid scratching and abrasion. You are advised to use a soft cloth and neutral soap.

STAINLESS STEEL SURFACES WITH ANTI-FINGERPRINT TREATMENT (SOME MODELS ONLY)

CAUTION: The stainless steel front surfaces used in some ovens are protected with a Special Lacquer to reduce finger-print marks.

To avoid damaging this lacquer, do not clean the stainless steel with abrasive cleaners or abrasive cloths or scouring pads.

ONLY SOAP/WARM WATER MUST BE USED TO CLEAN THE STAINLESS STEEL SURFACES.

Do not use harsh abrasive cleaners or sharp metal scrapers to clean the oven door glass since they can scratch the surface, which may result in shattering of the glass.

OVEN FITTING OUT

MODELS WITH EMBOSSED CAVITY

The oven shelves are provided with a security block to prevent accidental extraction.

They must be inserted operating as per figure 10.1.

To pull them out operate in the inverse order.

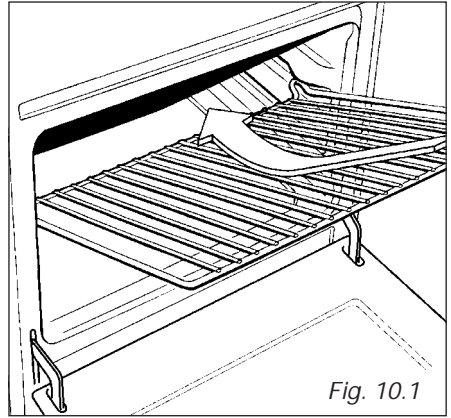

Fig. 10.1

MODELS WITH WIRE RACKS

- Assemble the wire racks to the oven walls using the 2 screws (Fig. 10.2). In the models with catalytic panels interpose the catalytic panels "A" with the arrow up (Fig. 10.2).

Models with side lamp: The catalytic panel with the hole for the side oven lamp must be positioned on the left oven wall. **DO NOT INTERPOSE THE CATALYTIC PANEL WITHOUT THE HOLE ON THE LEFT OVEN WALL.**

- Slide in, on the guides, the shelf and the tray (fig. 10.3). The shelf must be fitted so that the safety catch, which stops it sliding out, faces the inside of the oven.
- To dismantle, operate in reverse order.

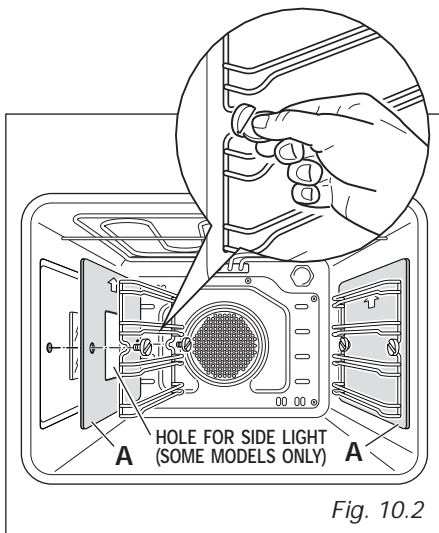

Fig. 10.2

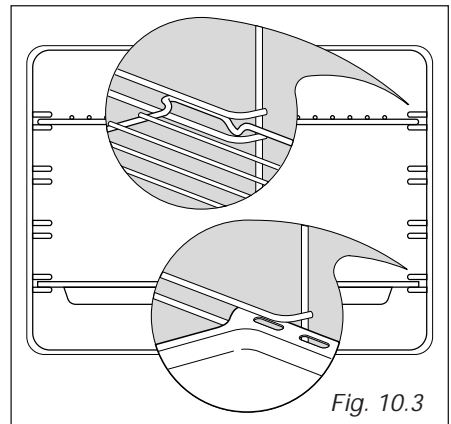

Fig. 10.3

MODELS WITH TILTING GRILL AND WIRE RACKS

Operate as follows:

- Assemble the wire racks on the oven walls using the 2 screws (fig. 10.4). In the models with catalytic panels interpose the catalytic panels "A" with the arrow up (fig. 10.4).

Models with side lamp: The catalytic panel with the hole for the side oven lamp must be positioned on the left oven wall. **DO NOT INTERPOSE THE CATALYTIC PANEL WITHOUT THE HOLE ON THE LEFT OVEN WALL.**

- Slide in, on the guides, the shelf and the tray (fig. 10.5).
The rack must be fitted so that the safety catch, which stops it sliding out, faces the inside of the oven.

To dismantle, operate as follows:

- Unscrewing the fixing screws and slide off the wire racks and the catalytic liners (if supplied) to the oven wall as in fig. 10.4.

The grill is secured to the rear wall of the oven on a hinge system that allows it to be lowered to allow proper access when cleaning the oven ceiling (fig. 10.6).

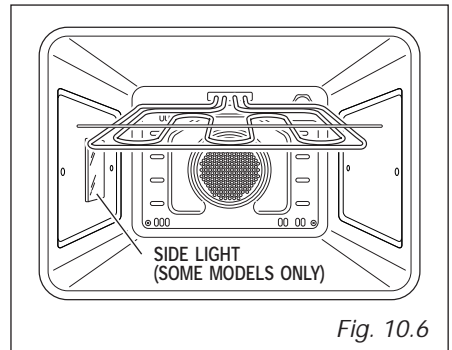
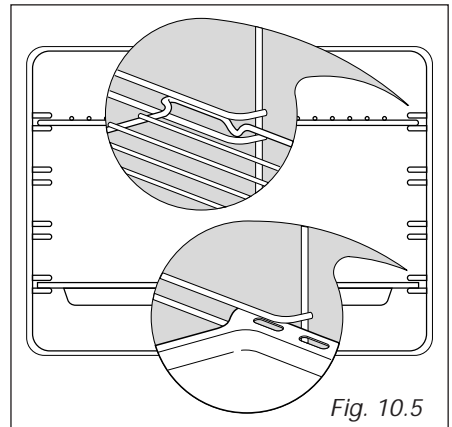
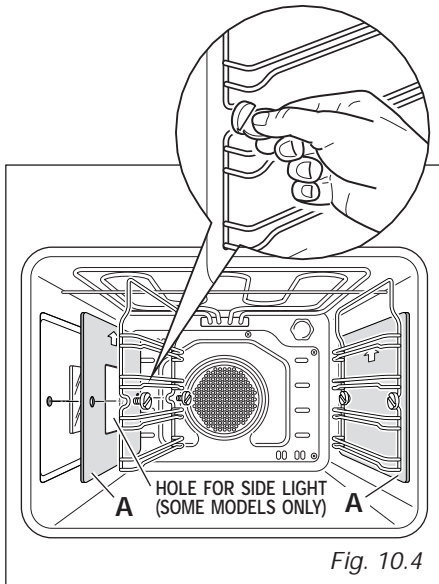

TELESCOPIC SLIDING SHELF SUPPORTS (SUPPLIED WITH SOME MODELS ONLY)

The telescopic sliding shelf supports make it safer and easier to insert and remove the oven shelves and trays. They stop when they are pulled out to the maximum position.

Important! When fitting the sliding shelf supports, make sure that you fit:

- The slides to the top wire of a rack. They do not fit on the lower wire.
- The slides so that they run out towards the oven door.
- Both sides of each pair of shelf slides.
- Both sides on the same level.
- **Models with tilting grill. Note:** you cannot fit the sliding shelf supports to the top shelf position (fig. 10.7b).

To fix the sliding shelf support onto the side racks:

- Screw the side rack onto the oven wall (Figs. 10.2 - 10.4).
- Fit the sliding shelf support onto the top wire of a rack and press (Figs. 10.7a - 10.7b). You will hear a click as the safety locks clip over the wire.

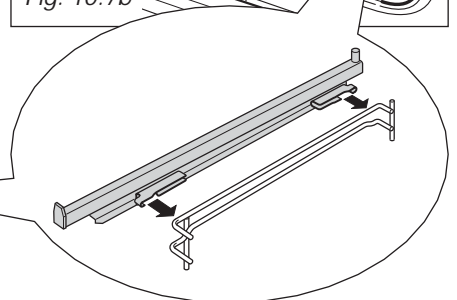
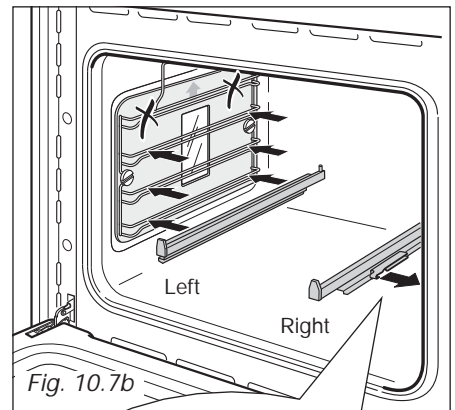
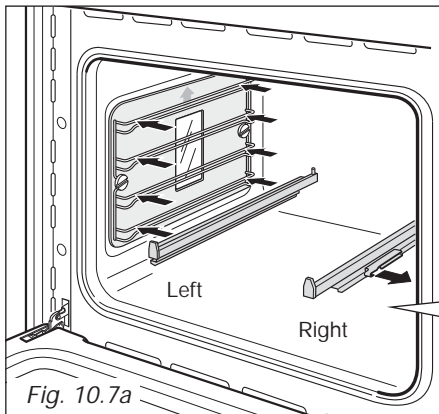

To remove the telescopic sliding shelf supports:

- Remove the side racks by unscrewing the fixing screws (Figs. 10.8a - 10.8b).
- Lay down the telescopic sliding shelf support and side racks, with the telescopic sliding shelf support underneath.
- Find the safety locks. These are the tabs that clip over the wire of the side rack (arrow 1 in Fig. 10.9).
- Pull the safety locks away from the wire to release the wire (arrow 2 in Fig. 10.9).

Cleaning the sliding shelf supports

- Wipe the supports with a damp cloth and a mild detergent only.
- Do not wash them in the dishwasher, immerse them in soapy water, or use oven cleaner on them.

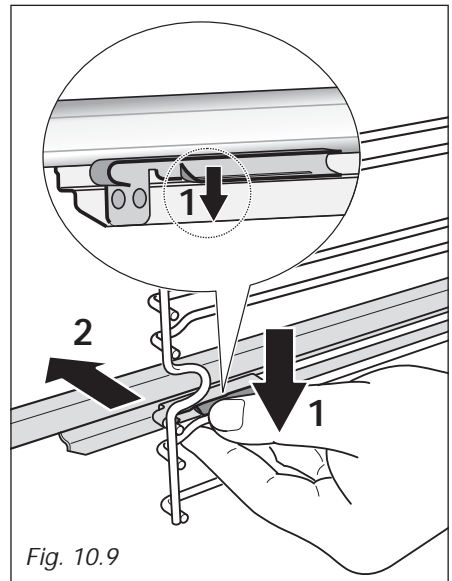
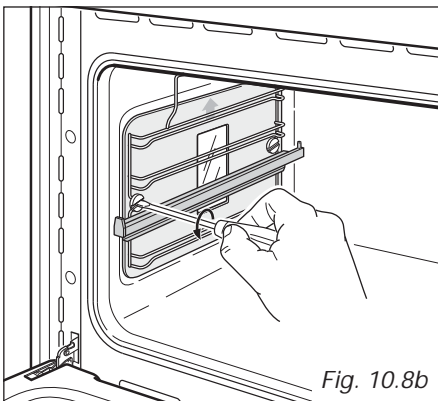
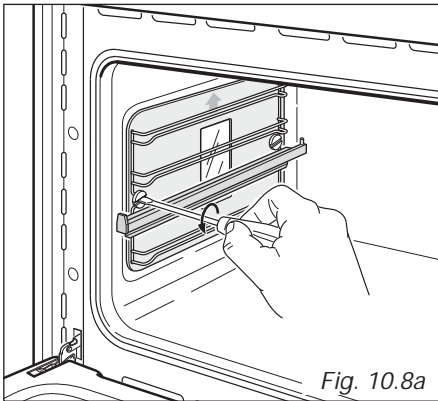

MODELS WITH SLIDING SHELVES

- Assemble the sliding shelves on the oven wall as in Fig. 10.10.
In the models with catalytic panels interpose the catalytic panels "A" with the arrow up (fig. 10.10).

Models with side lamp: The catalytic panel with the hole for the side oven lamp must be positioned on the left oven wall. **DO NOT INTERPOSE THE CATALYTIC PANEL WITHOUT THE HOLE ON THE LEFT OVEN WALL.**

The sliding shelves facilitate the insertion and removal of shelves during cooking; they stop when pulled out to the maximum position. These shelves support all accessory trays and are dishwasher safe.

- Position the shelf and tray as per fig. 10.11.
- To dismantle, operate in reverse order.

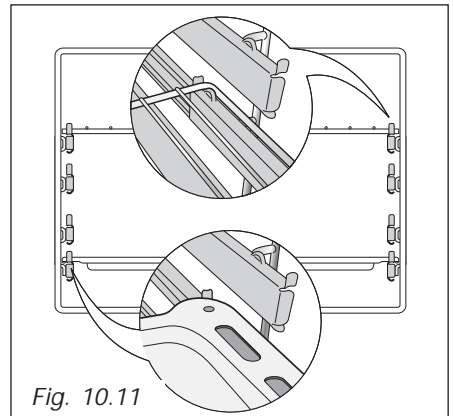
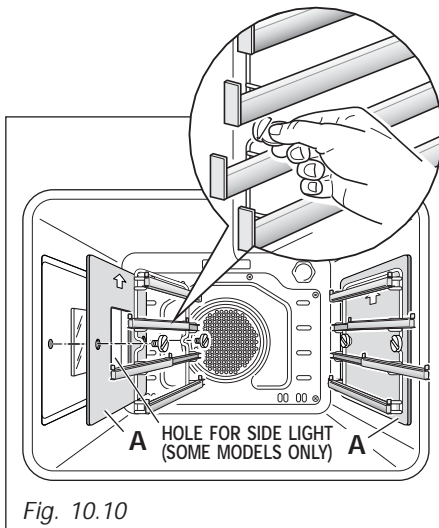

MODELS WITH TILTING GRILL AND SLIDING SHELVES

Operate as follows:

- Assemble the sliding shelves on the oven walls using the 2 screws (fig. 10.12).
In the models with catalytic panels interpose the catalytic panels "A" with the arrow up (fig. 10.12).

Models with side lamp: The catalytic panel with the hole for the side oven lamp must be positioned on the left oven wall. **DO NOT INTERPOSE THE CATALYTIC PANEL WITHOUT THE HOLE ON THE LEFT OVEN WALL.**

- Position the shelf and tray on the sliding shelves (fig. 10.13).

To dismantle, operate as follows:

- Unscrewing the fixing screws and slide off the sliding shelves and the catalytic liners (if supplied) to the oven wall as in fig. 10.12.

The grill is secured to the rear wall of the oven on a hinge system that allows it to be lowered to allow proper access when cleaning the oven ceiling (fig. 10.14).

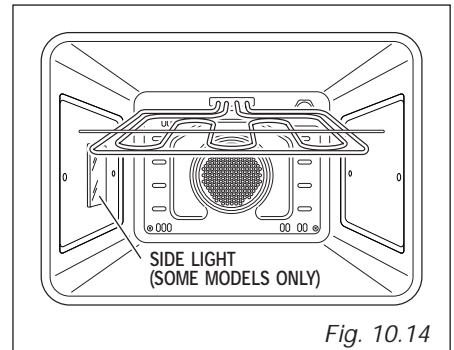
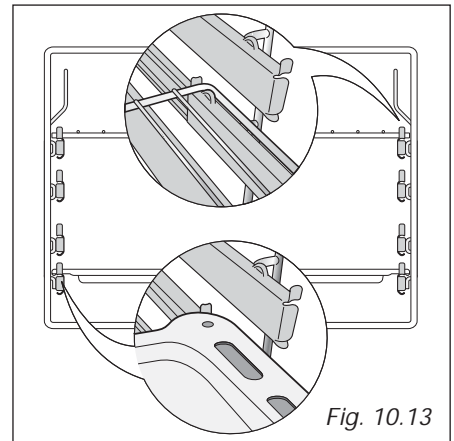
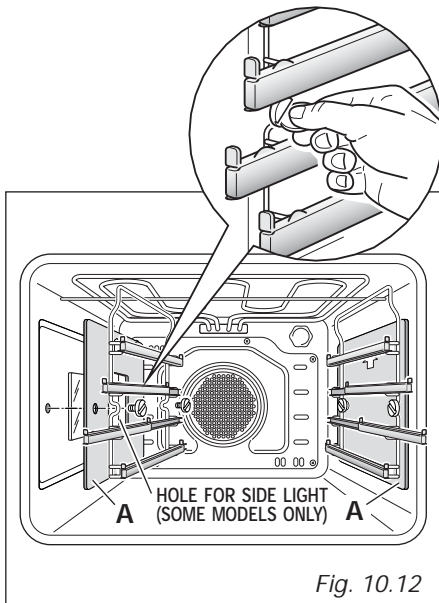

ADVICE FOR USE AND MAINTENANCE OF CATALYTIC PANELS

(SOME MODELS ONLY)

The catalytic panels are covered with special microporous enamel which absorbs and does away with oil and fat splashes during normal baking over 200°C.

If, after cooking very fatty foods, the panels remain dirty, operate the oven "idling" on max temperature for about 30 minutes.

These panels do not require to be cleaned, however it is advised to periodically remove them from the oven (at least the side panels) and to wash them with tepid soapy water and then wipe off with a soft cloth.

DO NOT CLEAN OR WASH THEM WITH ABRASIVE PRODUCTS OR WITH PRODUCTS CONTAINING ACIDS OR ALKALIS.

The side panels are reversible and when the catalytic microporous enamel degrades, they can be turned to the other side.

GREASE FILTER (SOME MODELS ONLY)

- Slide in the grease filter on the back of the oven as in fig. 10.15.

- **Clean the filter after any cooking!**

The grease filter can be removed for cleaning and should be washed regularly in hot soapy water (fig. 10.15).

- Always dry the filter properly before fitting it back into the oven.

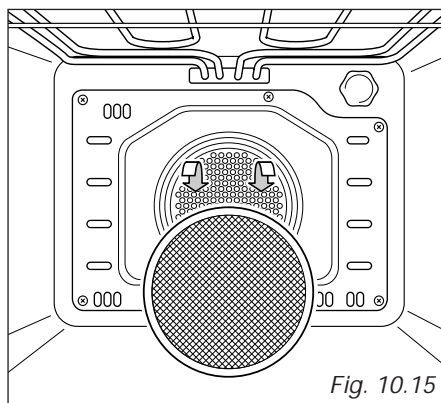

REPLACING THE OVEN LAMP

WARNING: Ensure the appliance is switched off before replacing the lamp to avoid the possibility of electric shock.

- Let the oven cavity and the heating elements to cool down;
- Switch off the electrical supply;

TOP RIGHT LAMP:

- Remove the protective cover **C** (fig. 10.16);
- Unscrew and replace the bulb **B** with a new one suitable for high temperatures (300°C) having the following specifications: 230-240V 50 Hz, E14 and same power (check watt power as stamped in the bulb itself) of the replaced bulb.
- Refit the protective cover;

LEFT LAMP (SOME MODELS ONLY):

- Remove the left wire rack (and the side catalytic panel for the models with side catalytic panels) by unscrewing the fixing screws.
- Press down from the top the protective cover **A** (fig. 10.16) and remove it by rotating on the lower side. **IMPORTANT:** never use screwdrivers or other utensils to remove the cover **A**. This could damage the enamel of the oven or the lampholder. Operate only by hands.
- Unscrew and replace the bulb **B** with a new one suitable for high temperatures (300°C) having the following specifications: 230-240V 50 Hz, E14 and same power (check watt power as stamped in the bulb itself) of the replaced bulb.
- Refit the protective cover **A** operating in reverse order. **ATTENTION:** the notch in the inner edge of the cover must be oriented toward the lamp.
- Assemble the left wire rack (and the side catalytic panel with the arrow up for the models with side catalytic panels).

Note: Oven bulb replacement is not covered by your guarantee.

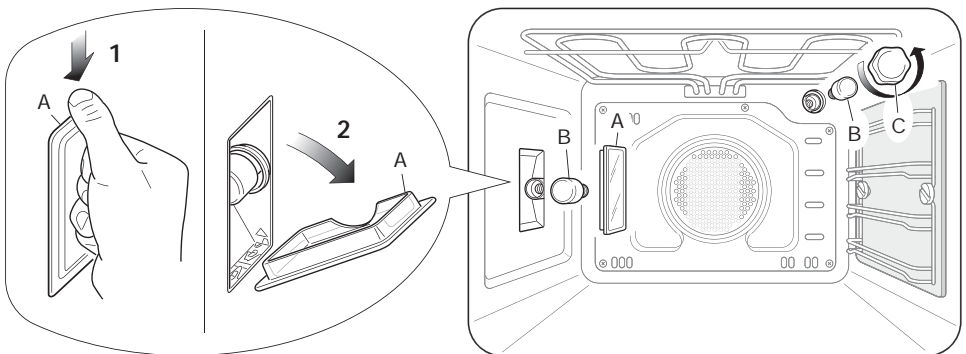
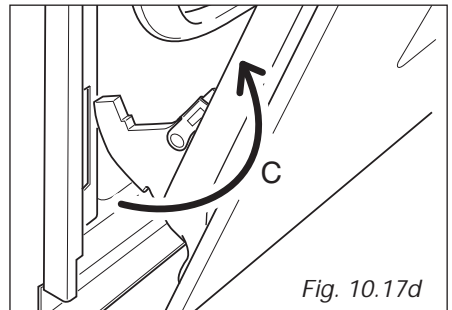
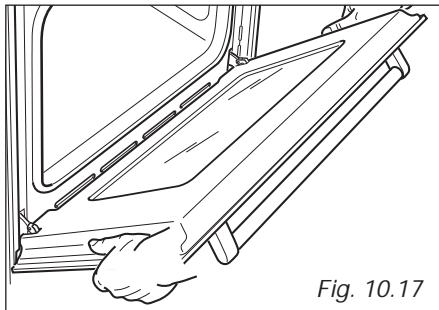
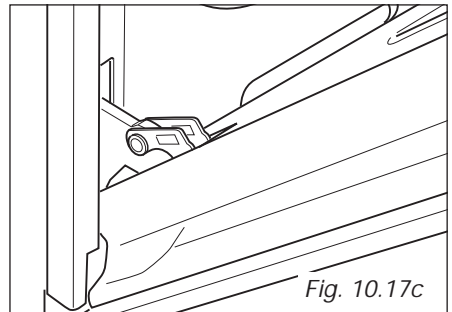
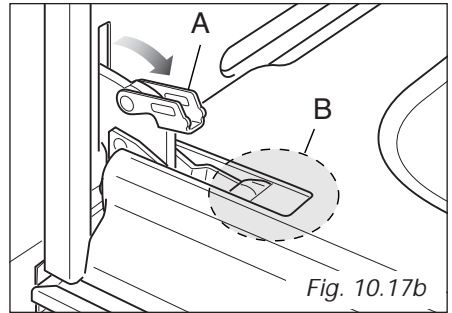
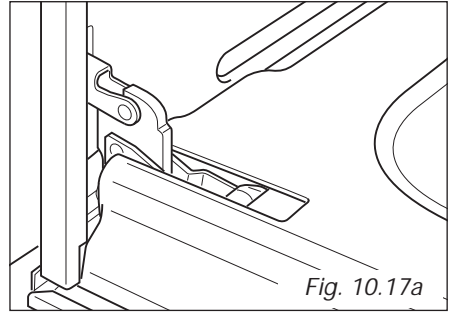

Fig. 10.16

REMOVING THE OVEN DOOR

The oven door can easily be removed as follows:

- Open the door to the full extent (fig. 10.17a).
- Open the lever **A** completely on the left and right hinges (fig. 10.17b).
- Hold the door as shown in fig. 10.17.
- Gently close the door (fig. 10.17c) until left and right hinge levers **A** are hooked to part **B** of the door (fig. 10.17b).
- Withdraw the hinge hooks from their location following arrow **C** (fig. 10.17d).
- Rest the door on a soft surface.
- To replace the door, repeat the above steps in reverse order.



MODELS WITH REMOVABLE INNER PANE OF GLASS

REMOVING THE INNER PANE

To clean the inner pane of the oven door on both sides operate as follows:

- Open the door to the full extent (fig. 10.18).
- Open the lever **A** completely on the left and right hinges (fig. 10.19).
- Gently close the door (fig. 10.20) until left and right hinge levers **A** are hooked to part **B** of the door (fig. 10.19).
- Remove the seal **G** by unhooking the no. 3 fixing hooks (fig. 10.21).
- Gently pull out the inner pane of glass (Fig. 10.22).
- Clean the glass with an appropriate cleaner. Dry thoroughly, and place on a soft surface.
- Now you can also clean the inside of the outer glass.

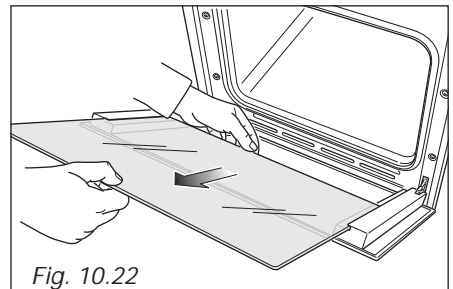
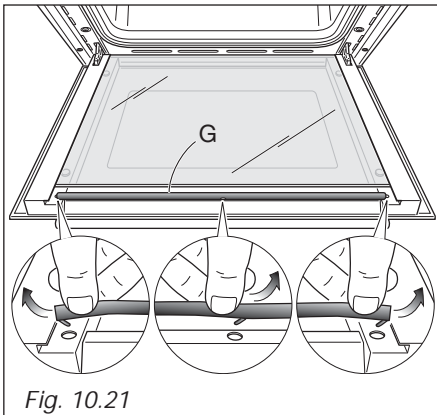
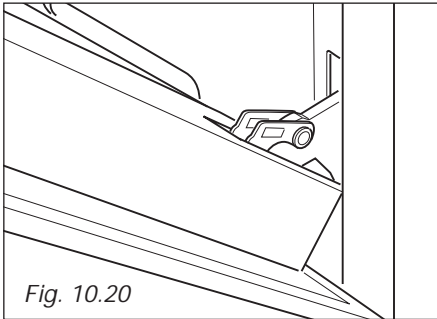
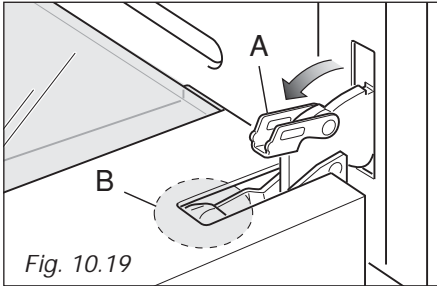
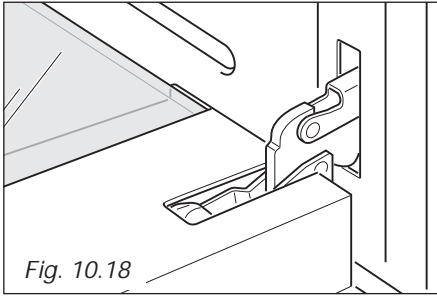

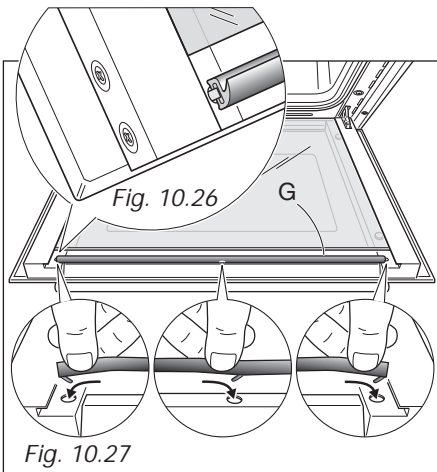
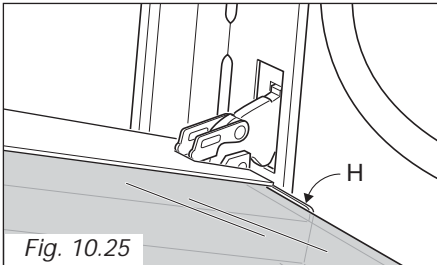
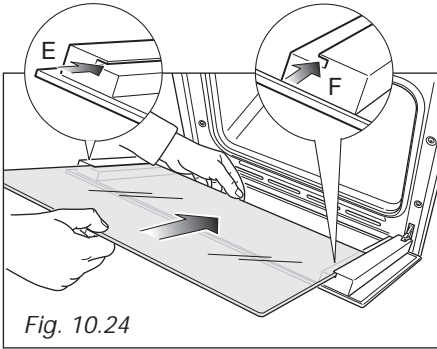
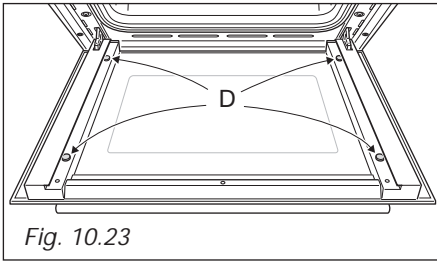

REASSEMBLING THE INNER PANE

To reassemble the inner pane of the oven door operate as follows:

- Make sure the door is locked open (see Fig. 10.20).
- Check the correct positioning of the no. 4 (four) silicon rubbers **D** (fig. 10.23).
- Check that you are holding the pane the correct way. You should be able to read the wording on it as it faces you.
- Insert the inner pane in the left **E** and right **F** side guides (fig. 10.24) and gently let it slide up to the retainers **H** (fig. 10.25).
- Reassemble the seal **G** in the correct way (fig. 10.26) by hooking the no. 3 fixing hooks in the proper holes (fig. 10.27).
- Open completely the oven door and close the lever **A** on the left and right hinges (fig. 10.28).

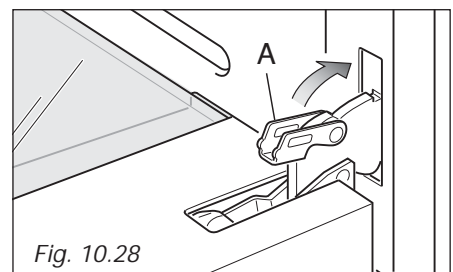
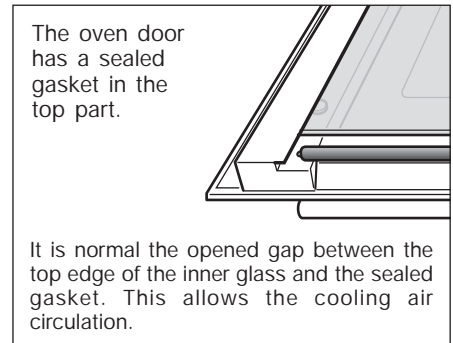

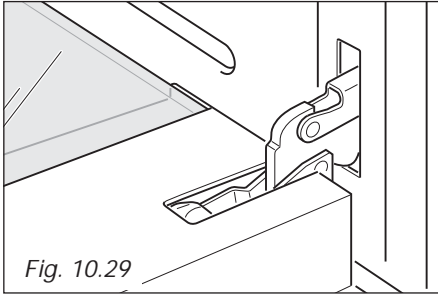

Fig. 10.29

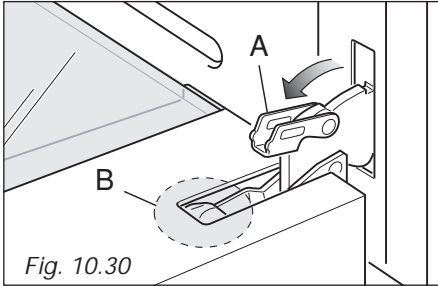

Fig. 10.30

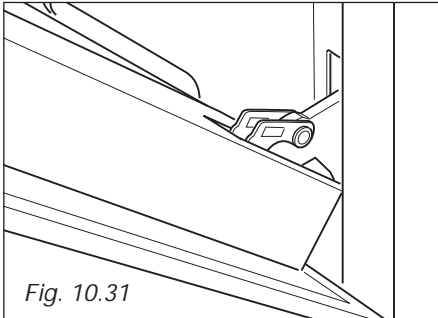

Fig. 10.31

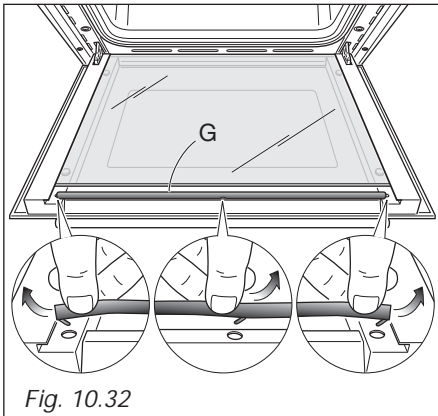

Fig. 10.32

MODELS WITH REMOVABLE INNER AND MIDDLE PANES OF GLASS (SOME MODELS ONLY)

The oven door is fitted with no. 3 panes:

- no. 1 outside;
- no. 1 inner;
- no. 1 in the middle.

To clean all panes on both sides it is necessary to remove the inner and the middle panes as follows:

REMOVING THE MIDDLE AND INNER PANES OF GLASS

1. Lock the door open:
 - Fully open the oven door (fig. 10.29).
 - Fully open the lever **A** on the left and right hinges. (fig. 10.30).
 - Gently close the door (fig. 10.31) until the left and right hinges are hooked to part **B** of the door (fig. 10.30).
2. Remove the inner pane:
 - Remove the seal **G** by unhooking the no. 3 fixing hooks (fig. 10.32).
 - Gently pull out the inner pane of glass (fig. 10.33).
 - Clean the glass with an appropriate cleaner. Dry thoroughly, and place on a soft surface.

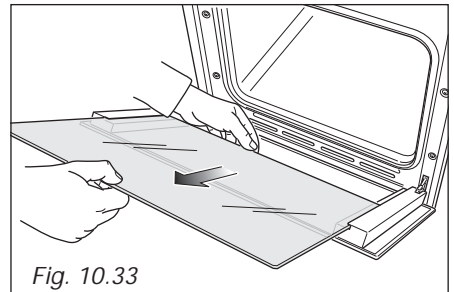

Fig. 10.33

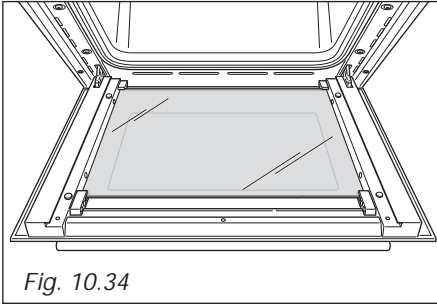

Fig. 10.34

3. Remove the middle pane:

- Gently unlock the middle pane of glass from the bottom clamps by moving it as in fig. 10.35.
- Gently lift the bottom edge of the pane (arrow 1 in fig. 10.36) and remove it by pulling it out from the top clamps (arrow 2 in fig. 10.36).
- Clean the glass with an appropriate cleaner. Dry thoroughly, and place on a soft surface.

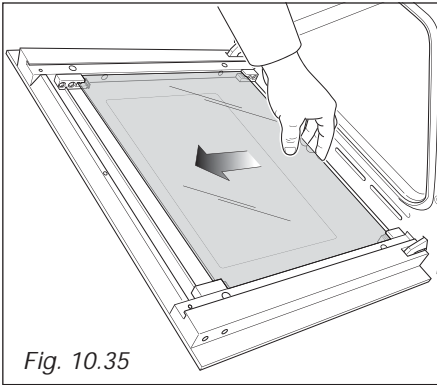

Fig. 10.35

Now you can also clean the inside of the outer glass.

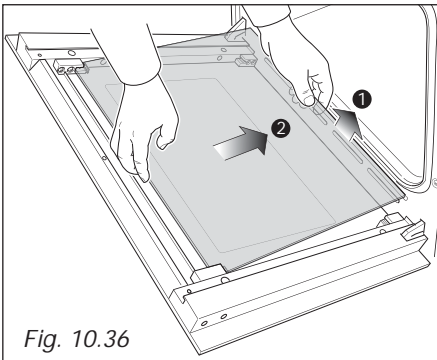

Fig. 10.36

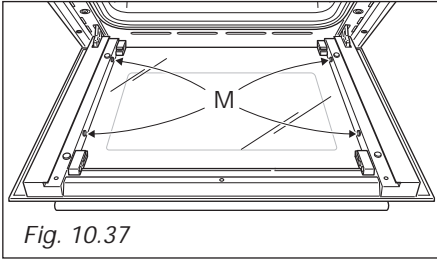

Fig. 10.37

REPLACING THE MIDDLE AND INNER PANES OF GLASS

1. Make sure the door is locked open (see fig. 10.31).
2. Replace the middle pane:
 - Check that the four rubber pads are in place (M in fig. 10.37).
 - Check that you are holding the pane the correct way. You should be able to read the wording on it as it faces you.
 - Gently insert the top edge of the pane into the top clamps (arrow 1 in fig. 10.38), then lower the pane and insert the bottom edge into the bottom clamps (arrow 2 in fig. 10.38); and then slide the pane into position (fig. 10.39).

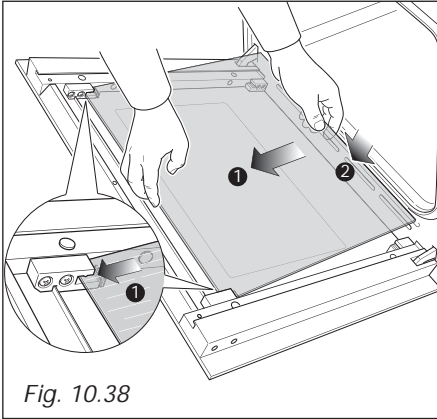

Fig. 10.38

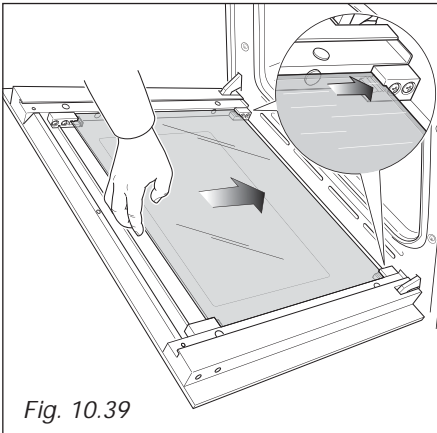
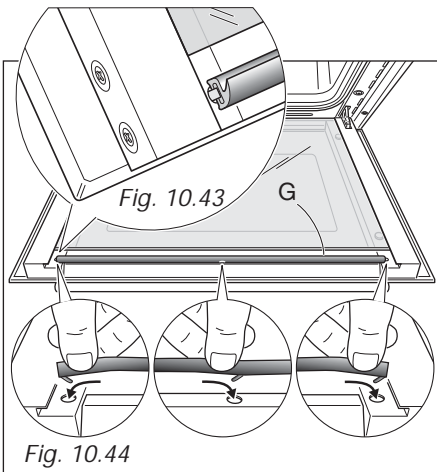
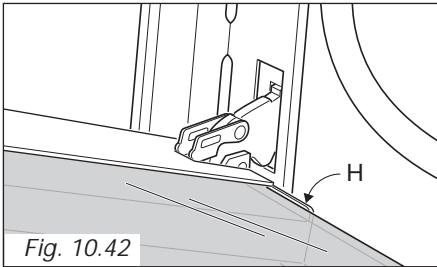
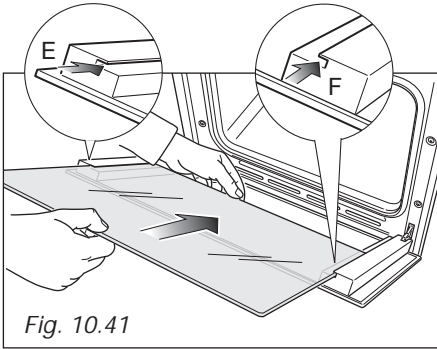
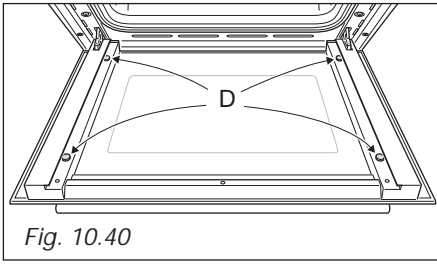
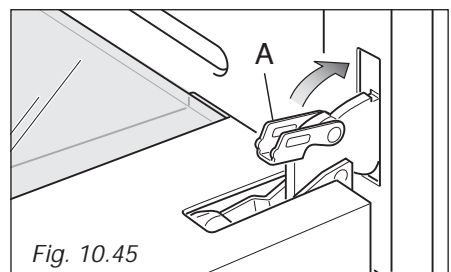
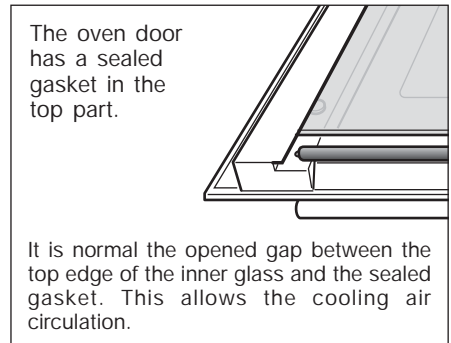

Fig. 10.39



3. Replace the inner pane:
 - Check that the four rubber pads are in place (**D** in fig. 10.40).
 - Check that you are holding the pane the correct way. You should be able to read the wording on it as it faces you.
 - Insert the pane in the left **E** and right **F** slide guides (fig. 10.41), and gently slide it to the retainers **H** (Fig. 10.42).
 - Reassemble the seal **G** in the correct way (fig. 10.43) by hooking the no. 3 fixing hooks in the proper holes (fig. 10.44).
4. Unlock the oven door by opening it completely and closing the lever **A** on the left and right hinges (fig. 10.45).



DO'S AND DO NOT'S

- ✓ Do always grill with the oven door closed.
- ✓ Do always remove the detachable handles when using the grill pan.
- ✓ Do read the user instructions carefully before using the oven for the first time.
- ✓ Do allow the oven to heat for one and a half hours, before using for the first time, in order to burn off any protective oils.
- ✓ Do clean your oven regularly.
- ✓ Do remove spills as soon as they occur.
- ✓ Do always use oven gloves when removing food shelves and trays from the oven.
- ✓ Do not allow children near the oven when in use.
- ✓ Do not allow fat or oils to build up in the oven trays, grill pan or oven base.
- ✓ Do not place cooking utensils or plates directly onto the oven base.
- ✓ Do not grill food containing fat without using the grid.
- ✓ Do not cover the grilling grid with aluminium-foil.
- ✓ Do not use the oven tray for roasting.
- ✓ Do not clean the oven without first turning off the electricity supply and allow to cool.
- ✓ Do not place hot enamel parts in water. Leave them to cool first.
- ✓ Do not allow vinegar, coffee, milk, saltwater, lemon or tomato juice to remain in contact with enamel parts.
- ✓ Do not use abrasive cleaners or powders that will scratch the surface of the enamel.
- ✓ Do not attempt to repair the internal workings of your oven.
- ✓ Do not grill with the oven door open as damage to the front panel will result.
- ✓ Do not line the oven walls with aluminium foil. Do not place baking trays or the drip tray on the base of the oven chamber.

FOR YOUR SAFETY

The product should only be used for its intended purpose which is for the cooking of domestic foodstuffs.

Under no circumstances should any external covers be removed for servicing or maintenance except by suitably qualified personnel.

Advice for the installer

Installation

11

IMPORTANT

The appliance should be installed by a **QUALIFIED INSTALLATION TECHNICIAN**. The appliance must be installed in compliance with regulations in force.

The oven can be fitted in standard units, width and depth 60 cm. Installation requires a compartment as illustrated in figures 11.1 and 11.2. On the lower side, the oven must lay on supports standing the oven weight. The 4 screws serve as fixing.

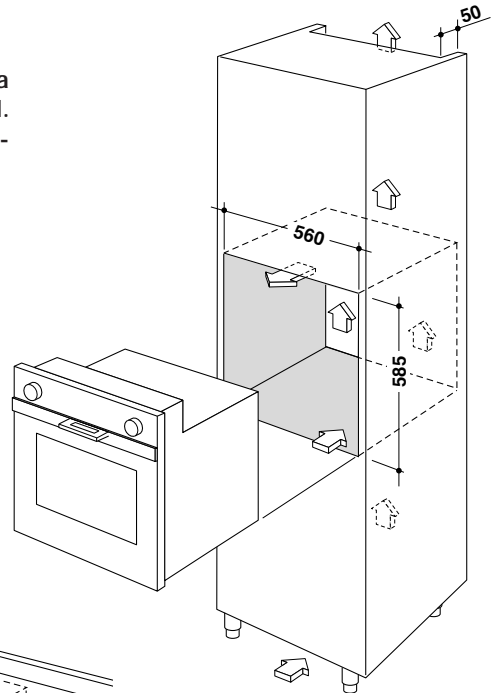

Fig. 11.1

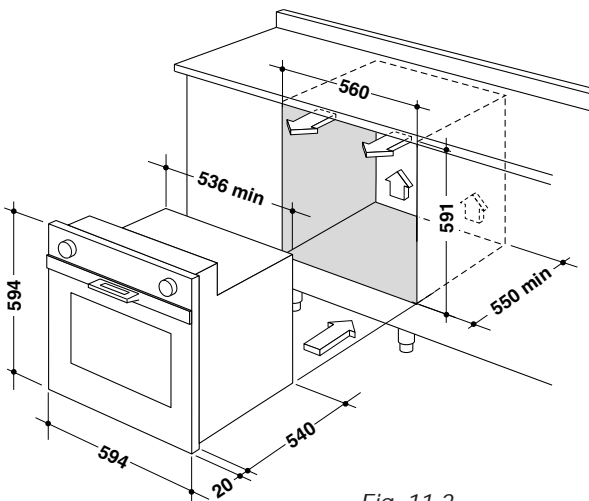

Fig. 11.2

WARNING

When correctly installed, your product meets all safety requirements laid down for this type of product category. However special care should be taken around the rear or the underneath of the appliance as these areas are not designed or intended to be touched and may contain sharp or rough edges, that may cause injury.

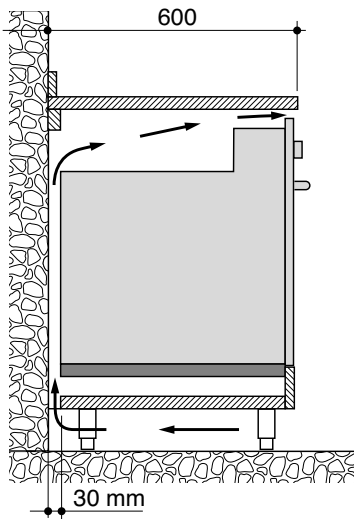

Fig. 11.3

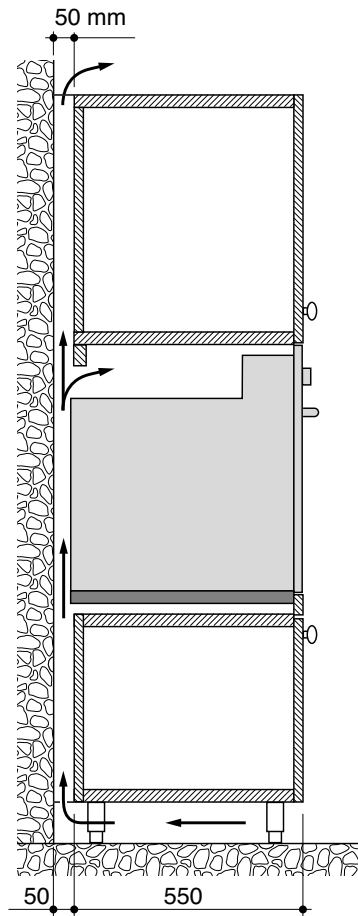

Fig. 11.4

To ensure internal ventilation, aeration channels must be provided as illustrated in the figures 11.3 and 11.4.

The walls surrounding the oven must be made of heat-resistant material. Taking care NOT to lift the oven by the door handle.

FIXING THE OVEN

Introduce the oven into the furniture opening and fix it with screws (not supplied) as figure 11.5. It is essential that the oven rests on a surface which will support its weight, as the screw fixing is only complementary.

Note

It is essential that when installing your oven adequate air circulation is allowed for within the installation. See figures 11.3 - 11.4. Inadequate air circulation may greatly impair the performance of your oven and may effect adjacent cabinets due to an increase in temperature.

Caution

Do not lift this oven by the door handle

Adjust the hinges of furniture doors adjacent to the oven to allow a 4-5 mm gap between the furniture door and the oven frame.

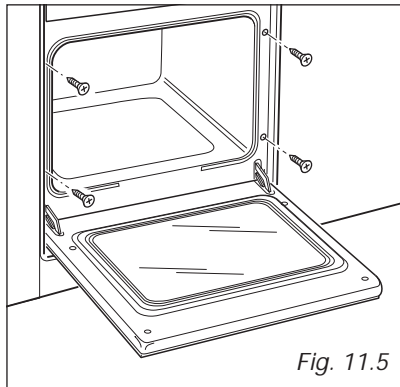

Fig. 11.5

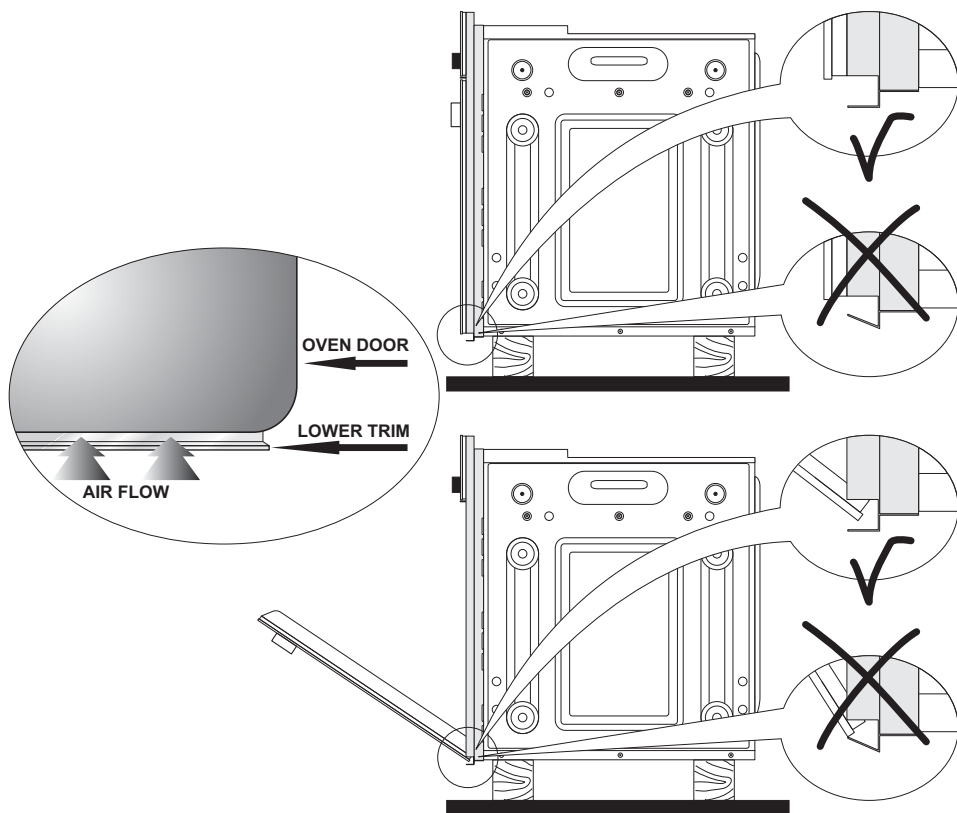

Fig. 11.6

IMPORTANT:

To avoid damage to the lower trim please note the following instructions.

The lower trim is designed to allow for good air circulation and the correct opening of the oven door.

To ensure the trim is not damaged due to the appliance being placed on the floor, the appliance should be suitably supported as in above illustrations.

After installation the appliance door should be slowly opened to ensure no damage has occurred.

No responsibility for lower trim damage will be accepted if these instructions have not been followed.

Before effecting any intervention on the electrical parts the appliance must be disconnected from the network.

GENERAL

- The connection to the electrical network must be carried out by qualified personnel and must be according to existing norms.
- The appliance must be connected to the electrical network verifying above all that the voltage corresponds to the value indicated on the specifications plate and that the cables section of the electrical plant can bear the load which is also indicated on the plate.
- If the appliance is supplied without a power supply plug and if you are not connecting directly to the mains, a standardized plug suitable for the load must be fitted.
- The colours of the wires in the appliance power cable may not correspond with the colours marked on the terminals of your electrical plug. The plug should always be wired as follows:
 - connect the green/yellow wire to the terminal marked with the letter E or the earth symbol or coloured green/yellow;
 - connect the blue wire to the terminal marked with the letter N or coloured black;
 - connect the brown wire to the terminal marked with the letter L or coloured red.

- The bi-polar plug must be connected to an outlet connected to the grounding unit in conformity to security norms.
- If the oven is to be connected directly to the mains, it must be placed with an omnipolar switch with minimum opening between the contacts of 3 mm between the appliance and the mains.
- The power supply cable must not touch the hot parts and must be positioned so that it does not exceed 75°C at any point.
- Once the oven has been installed, the switch or socket must always be accessible.
- If the power supply cable is damaged it must be substituted by a suitable cable available in the after sales service.

N.B. For connection to the mains, do not use adapters, reducers or branching devices as they can cause overheating and burning.

If the installation requires alterations to the domestic electrical system call an expert.

He should also check that the socket cable section is suitable for the power absorbed by the appliance.

The connection of the appliance to the grounding unit is mandatory. The manufacturer declines every responsibility for any inconvenience resulting from the inobservance of this condition.

CONNECTION OF THE POWER SUPPLY CABLE

Unhook the terminal board cover by inserting a screwdriver into the two hooks "A" (fig. 12.1).

Open the cable gland by unscrewing screw "F" (fig. 12.2), unscrew the terminal screws and remove the cable.

The new supply cable, of suitable type and section, is connected to the terminal board following the diagram fig. 12.3.

FEEDER CABLE SECTION TYPE HO5RR-F

230 V ~ 3 x 1,5 mm²

