

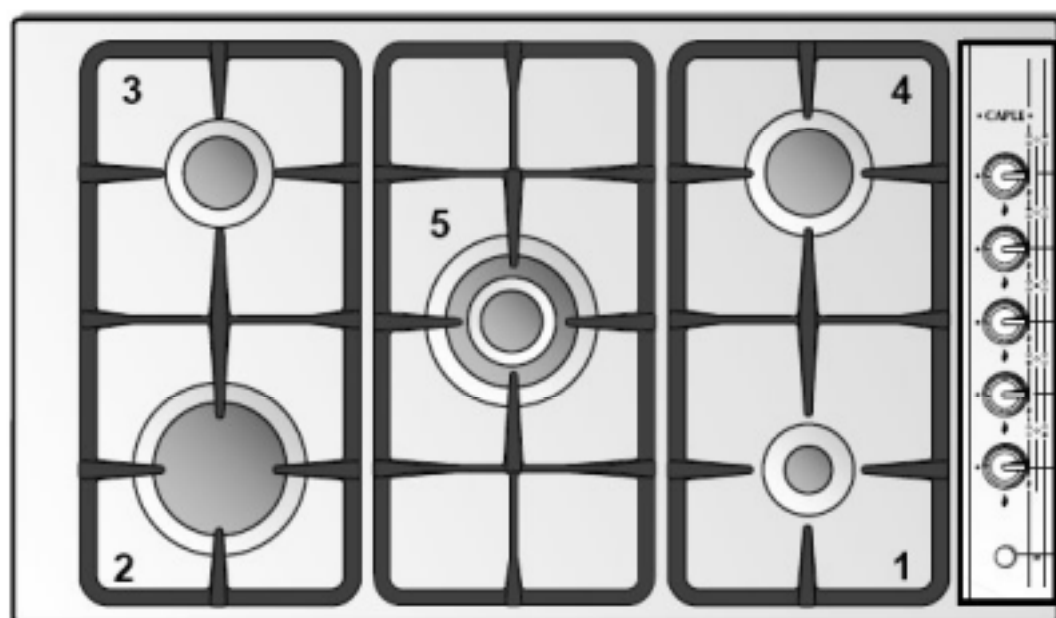

C761G/SS

Caple 90cm 5 Burner Gas Hob



INSTRUCTION MANUAL

Thank you for buying your new CAPLE Gas Hob. To ensure that you get the best results from your new CAPLE Gas Hob, we strongly suggest that you read this instruction manual thoroughly before use. This manual contains installation advice, usage instructions and a cleaning guide, as well as other important facts about your CAPLE Gas Hob. If treated with care, your CAPLE Gas Hob should give you years of trouble-free cooking.

Contents

Installation Requirements.....	3
Gas Installation	4
Installation	5
How To Use Your Gas Hob	8
Cleaning and Maintenance	11
Your Guarantee	12

For Spare Parts, Technical Advice
or Product Service call the
CAPLE HELPLINE on 0870 241 1142

(Answerphone outside office hours)

The **CE** marking confirms that the appliance conforms to the following EU directives:

- safety requirements of the "Gas" Directive 90/396/EEC;
- safety requirements of EEC Directive "Low voltage" 73/23;
- protection requirements of EEC Directive "EMC" 89/336;
- requirements of EEC Directive 93/68.

Installation Requirements

WARNING!
ELECTRICITY CAN BE
EXTREMELY DANGEROUS.
THIS APPLIANCE MUST BE EARTH-
ED.

Electrical Installation

This appliance must be connected by a qualified electrician using fixed wiring via a double pole isolating switch (fig. 1).

As the colours of the wires in the mains lead for the appliance, may not correspond with the coloured markings identifying the terminals in your spur box, proceed as follows:

- 1) The wire which is coloured green and yellow must be connected to the terminal marked **E** (Earth)  or coloured Green.
- 2) The wire which is coloured blue must be connected to the terminal marked **N** (Neutral), or coloured Black.
- 3) The wire which is coloured brown must be connected to the terminal marked **L** (Live), or coloured Red.

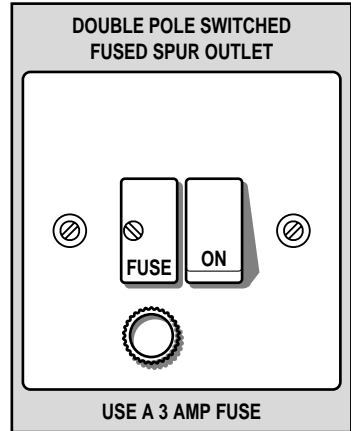

Fig. 1

Cat. I 2H - Class 3

Technical Information

Total absorbed power	11.25 kW
Double-ring burner	3.20 kW
Rapid burner (1)	3.05 kW
Rapid burner (2)	2.40 kW
Semi rapid burner	1.60 kW
Auxiliary burner	1.00 kW
Voltage	230 V Single phase

Gas Installation

Gas installation

This appliance should be fitted by a C.O.R.G.I. registered fitter.

The installation must comply with Gas Safety (installation and use) Regulations 1994.

It is illegal to provide any assistance in the installation of gas appliance except to C.O.R.G.I registered installers.

Any C.O.R.G.I registered fitter requiring help must provide name, address and registration number. Information supplied will be validated before help is provided.

This appliance is predisposed and adjusted to operate with Natural Gas at 20 mbar.

After connecting to the mains, check that the couplings are correctly sealed, using soapy solution, but never a naked flame.



INJECTORS TABLE

Cat: I 2H

BURNERS	Nominal input [kW]	Reduced input [kW]	Natural Gas - 20 mbar	
			By-pass [1/100 mm]	Ø injector [1/100 mm]
Auxiliary (A)	1,00	0,32	40	65*
Semi-rapid (SR)	1,60	0,39	43	85*
Rapid (R2)	2,40	0,58	55	110*
Rapid (R1)	3,05	0,67	60	115 (.15*)
Double-ring (DR)	3,20	0,77	62	125*

* = Injector brand

Lubrication of the gas taps

If the gas tap becomes stiff, it is necessary to dismount it accurately clean it with gasoline and spread a bit of special grease resistant to high temperatures on it.

The operations must be executed by a qualified technician.

Installation

The hob must be installed by a qualified technician and in compliance with local safety standard.

Take care not to lose or mishandle any parts when unpacking the appliance.

Positioning the appliance

The hob must be installed a minimum of 50 mm from the back wall and 150 mm from any vertical surface either side of the hob.

Adjacent units must be a minimum of 450 mm above the work surface.

If you are installing a cooker hood above the hob there must be a minimum height of 750 mm between the appliance.

If a cooker hood is not installed, there must be a minimum height of 900 mm between cabinets above the hob.

This hob must not be installed above refrigeration products.

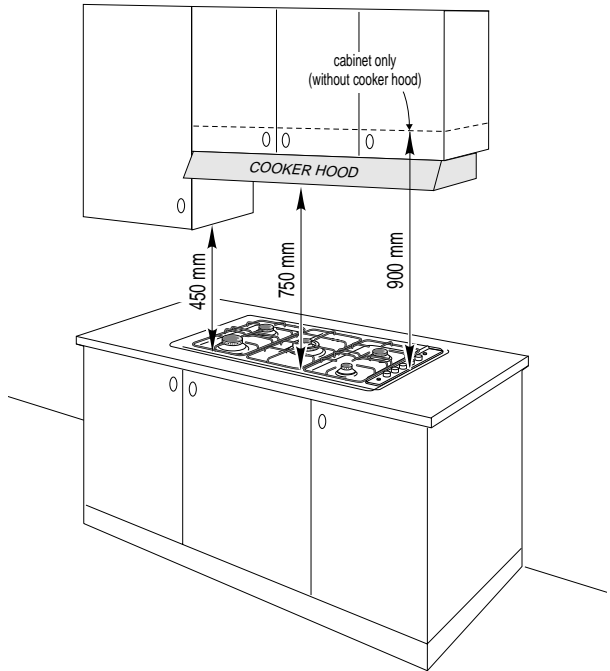

Fig. 2

Ventilation

All rooms require a window which can be opened or equivalent, while some rooms require a permanent vent in addition to a window.

This unit must not be used in a room with less than 5 m³.

Room Volume	Air vent necessary (effective area)
5 m ³	100 cm ²
5 m ³ to 10 m ³	50 cm ²
Greater than 11 m ³	No air vent necessary
A room 5 m ³ to 10 m ³ with a door opening to the outside	No permanent air vent necessary

The above requirements allow use of a gas oven and grill but if there are other fuel burning appliances in the same room BS5440 part 2: 1989 (ventilation) should be consulted to determine the necessary air venting requirements.

Installation

1. The hob requires a space in the kitchen work surface as shown in fig 3.

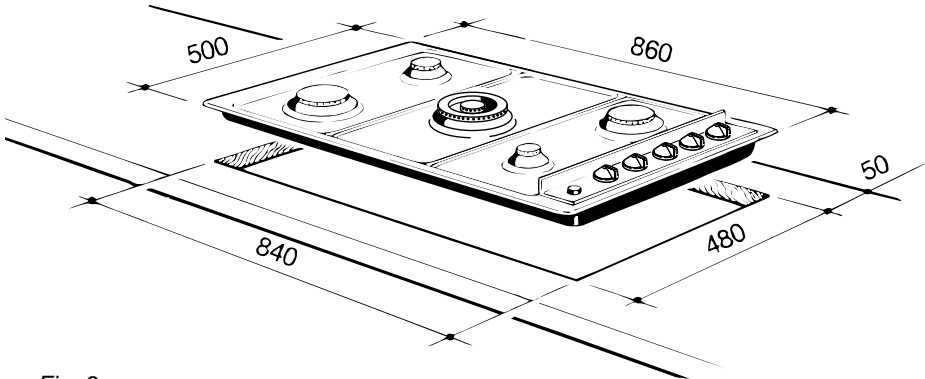

Fig. 3

NOTE: A partition between the base of the hob and the cupboard below should be fitted 100 mm below the worktop if the cupboard is to be used for storage. Never place perishable foods in the cupboard below the hob.

2. Apply the adhesive seal around the edge of the hob, making sure that the ends do not overlap or leave a space (fig. 4).
3. Attach the hob to the worktop using the brackets supplied as indicated in figure 5.
4. Tighten carefully.
5. Using a sharp tool, trim any excess gasket which protrudes from the edge of the hob.
6. Assemble the three piece burners. Take care to properly locate the assembled burner on the burner base (fig. 6).

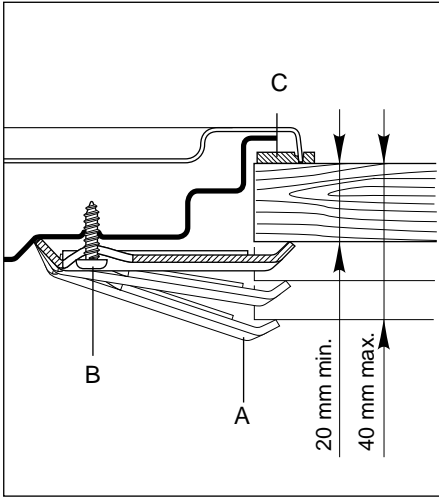

Fig. 4

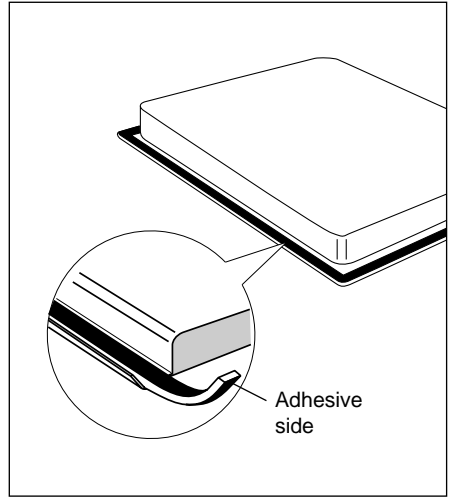
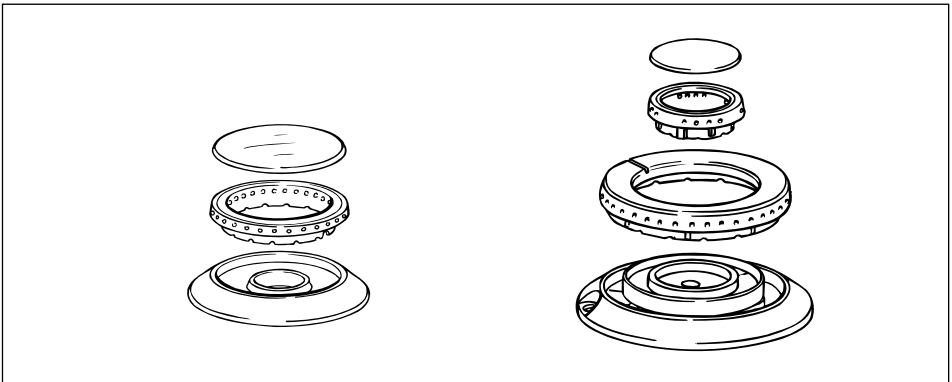

Fig. 5

Fig. 6



How to use your gas hob

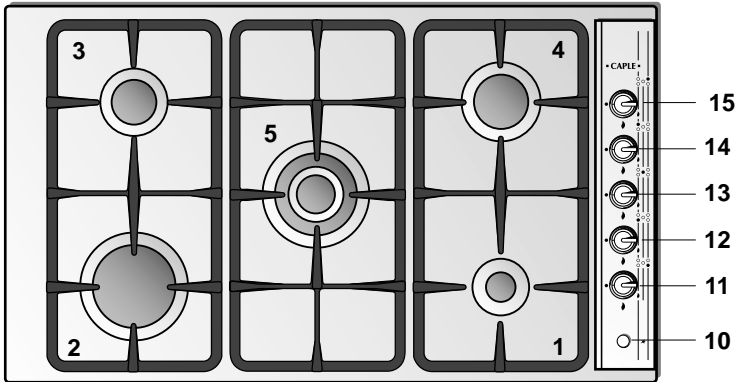

Fig. 7

COOKING HOB

1. Auxiliary burner (A) - 1,00 kW
2. Rapid burner (R1) - 3,05 kW
3. Semirapid burner (SR) - 1,60 kW
4. Rapid burner (R2) - 2,40 kW
5. Double-ring burner 3,20 kW



CONTROLS DESCRIPTION

10. Electric lighter button
11. Burner control knob 1 (A)
12. Burner control knob 2 (R1)
13. Burner control knob 5 (DR)
14. Burner control knob 3 (SR)
15. Burner control knob 4 (R2)

Use of the burners

The arrival of the gas at the burner is controlled by a knob (fig. 8) which operates the safety closing tap.

When the mark on the knob coincides with the symbols on the panel at the side, we will have:

- symbol  tap off (burner off)
- symbol:  full flow (burner at maximum)
- symbol:  slow (burner at minimum).

To open the tap which allows the gas to reach the burner push the knob and turn it to the left.

To close it, turn the knob to the right until the safety device releases.

The maximum flow is used for boiling, while the slow flow is used for simmering food or keeping it on the boil.

All the operating positions must be chosen between the maximum and minimum positions, never between the maximum and off positions.

Lighting the burners

Turn the knob to full flow and push the button with the ★ symbol (fig. 9) until the burner lights, then adjust the flame.

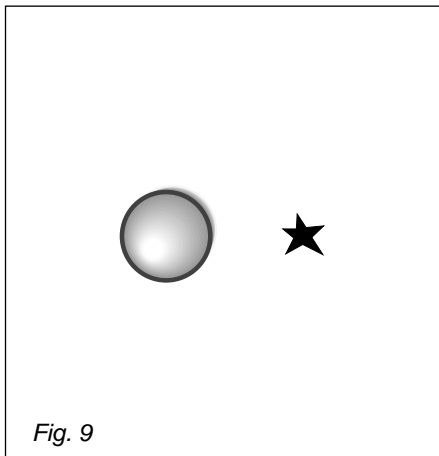
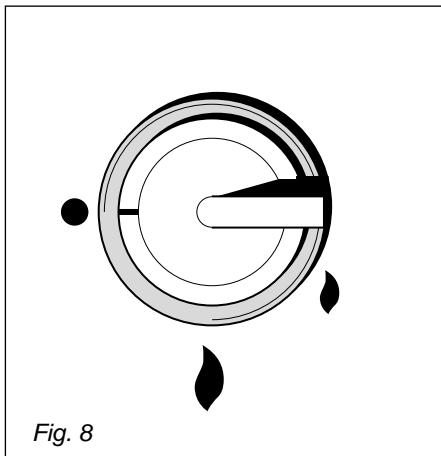

How to use your gas hob

Cooking hints

The burners are different sizes, and can be used in different ways; the largest for boiling, to seal meat or foods that are cooked quickly and the smallest for stews and sauces.

Always ensure that you use the correct size of saucepan.

For fast boiling, make sure that the flame just reaches the edge of the pan. Flames going up the side of the pan means wasted heat and the contents of the pan will take longer to boil.

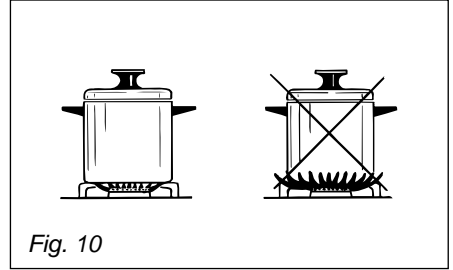

Warning:

**During cooking the hob becomes very hot, especially around the cooking areas.
Keep young children away.**

Cleaning and Maintenance

Advice for the user

- When the appliance is not being used, switch off the gas inlet tap. Check the state of the connection hose to the bottle or to the gas distribution duct occasionally; it must be in perfect condition and must be replaced if there are any defects or depending on the date of use (case of a connection where the hose can be inspected).
- Regular lubrication of the taps must be performed only by qualified staff. If there are operating problems, contact the After-Sales Service Centre.

General advice

- **Before you begin cleaning, you must ensure that the appliance is switched off.**
- It is advisable to clean when the appliance is cold and especially when cleaning the enamelled parts.
- Avoid leaving alkaline or acidic substances (lemon juice, vinegar, etc.) on the surfaces.
- Avoid using cleaning products with a chlorine or acidic base.
- Do not use a steam cleaner because the moisture can get into the appliance thus make it unsafe.

Enamelled parts

All the enamelled parts must only be cleaned with a sponge and soap or other non-abrasive products. Preferably clean with a cloth.

Stainless steel

Clean with a suitable product. Always dry carefully.

Black burners (“oxi-black” coating)

They can be removed and washed only with soapy water.

Detergents can be used but must not be abrasive or corrosive.

Do not use abrasive sponges or pads.

Do not put in dishwasher.

After each cleaning, make sure that the burner-caps, as well as the burners, have been well wiped off and **CORRECTLY POSITIONED**.

It is essential to check the correct position of the burner-caps as the least displacement from the housing may cause serious problems.

For appliances with electric lighting, check that the electrode is always clean, to allow regular production of sparks.

Troubleshooting

If you acquire a problem with your hob, check the following points before calling an engineer.

1. The power is switched on.
2. The controls are switched on.
3. Both the fuse and the mains fuse are intact.
4. The gas supply is connected to the appliance.

If you are in any doubt about carrying out these checks, call the **CAPLE Helpline on 0870 241 1142**.

CAPLE “Built-in” Service

Should you require service at any time, please contact the **Caple Helpline on 0870 241 1142.**

Caple have a nationwide service network of engineers who will respond quickly to your call.

Always replace spare parts with genuine **Caple** spares. These are available from authorised **Caple Service Centres** or by mail order from our **National Service Stores, simply telephone 0870 241 1142.**

When ordering parts always quote the model number and serial number of your appliance.

YOUR GUARANTEE

CAPLE guarantees all parts of this product for one year from the date of purchase. During that time, should it become necessary CAPLE engineers will replace or repair all defective parts free of charge, except for parts subject to fair wear and tear, such as lightbulbs.

Parts and the engineers labour costs are chargeable after the first 12 months.

To qualify for benefits under the guarantee, you must be able to provide proof of date of purchase and the appliance must have been supplied, installed and used for domestic purposes only in accordance with CAPLE instructions.

Consequential losses and accidental damage to the product are not covered by the guarantee.

This guarantee does not affect your statutory or common law rights.

CAPLE cannot be responsible for the results of using this appliance for any other purposes other than those described in these instructions.