

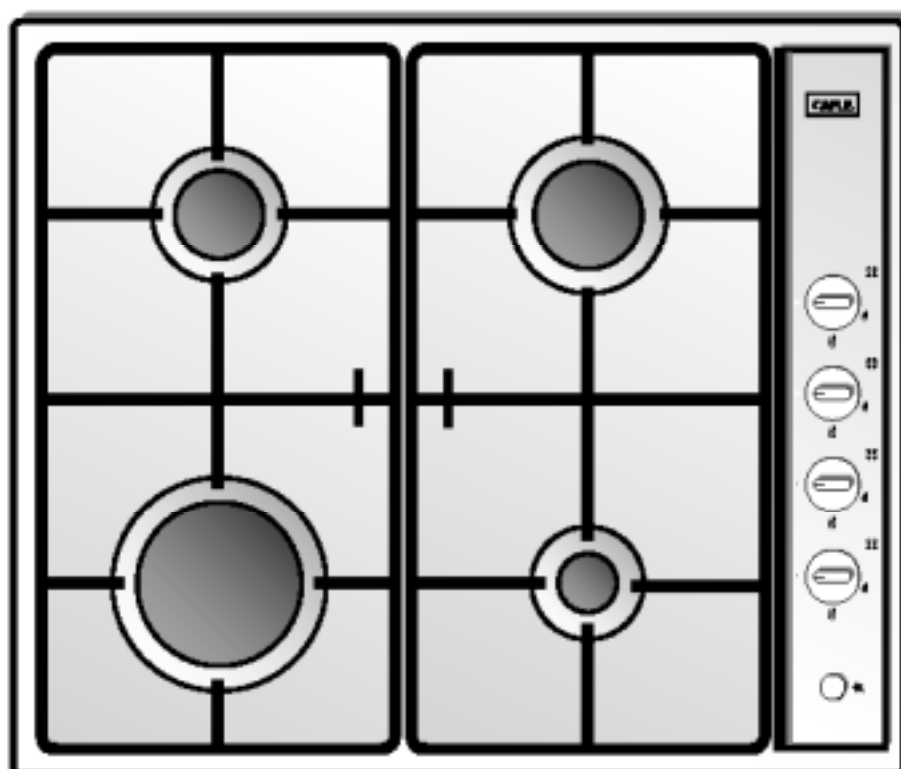

C700G/BLU

Cable Gas Hob Blue



INSTRUCTION MANUAL

Thank you for buying your new CAPLE Gas Hob. To ensure that you get the best results from your new CAPLE Gas Hob, we strongly suggest that you read this instruction manual thoroughly before use. This manual contains installation advice, usage instructions and a cleaning guide, as well as other important facts about your CAPLE Gas Hob. If treated with care, your CAPLE Gas Hob should give you years of trouble-free cooking.

Contents

Installation Requirements.....	3
Installation	4
How To Use Gas Hob	6
Your Guarantee	8

Technical Information

Cat. **I 2H** - Class **3**

Total absorbed power	8.05 kW
Rapid burner (1)	3.05 kW
Rapid burner (2)	2.40 kW
Semi rapid burner	1.60 kW
Auxiliary burner	1.00 kW
Voltage	230 V Single phase

For Spare Parts, Technical Advice
or Product Service call the
CAPLE HELPLINE on 01245 322770

(Answerphone outside office hours)

Installation Requirements

WARNING!
ELECTRICITY CAN BE
EXTREMELY DANGEROUS.
THIS APPLIANCE MUST BE
EARTHED.

Electrical Installation

This appliance must be connected by a qualified electrician using fixed wiring via a double pole isolating switch (fig. 1).

As the colours of the wires in the mains lead for the appliance, may not correspond with the coloured markings identifying the terminals in your spur box, proceed as follows:

- 1) The wire which is coloured green and yellow must be connected to the terminal marked **E** (Earth)  or coloured Green.

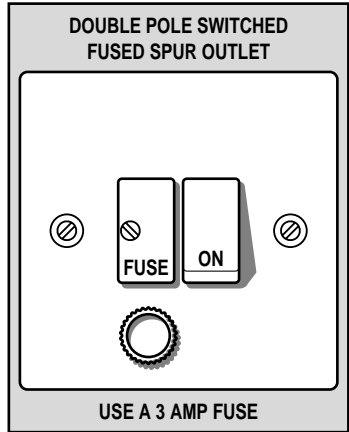

Fig. 1

- 2) The wire which is coloured blue must be connected to the terminal marked **N** (Neutral), or coloured Black.
- 3) The wire which is coloured brown must be connected to the terminal marked **L** (Live), or coloured Red.

Gas installation

This appliance should be fitted by a C.O.R.G.I. registered fitter.

The installation must comply with Gas Safety (installation and use) Regulations 1994.

It is illegal to provide any assistance in the installation of gas appliance except to C.O.R.G.I registered installers.

Any C.O.R.G.I registered fitter requiring help must provide name, address and registration number. Information supplied will be validated before help is provided.

This appliance is predisposed and adjusted to operate with Natural Gas at 20 mbar.

GB
INJECTORS TABLE
Cat: I 2H

BURNERS	Nominal input [kW]	Reduced input [kW]	Natural Gas - 20 mbar	
			By-pass [1/100 mm]	Ø injector [1/100 mm]
Auxiliary (A)	1,00	0,32	40	65*
Semi-rapid (SR)	1,60	0,39	43	85*
Rapid (R2)	2,40	0,58	55	110*
Rapid (R1)	3,05	0,67	60	115 (.15*)

* = Injector brand

Installation

Take care not to lose or mishandle any parts when unpacking the appliance.

Positioning the appliance

The hob must be installed a minimum of 50 mm from the back wall and 150 mm from any vertical surface either side of the hob.

Adjacent units must be a minimum of 366 mm above the work surface.

If you are installing a cooker hood above the hob there must be a minimum height of 750 mm between the appliance.

If a cooker hood is not installed, there must be a minimum height of 900 mm between cabinets above the hob.

This hob must not be installed above refrigeration products.

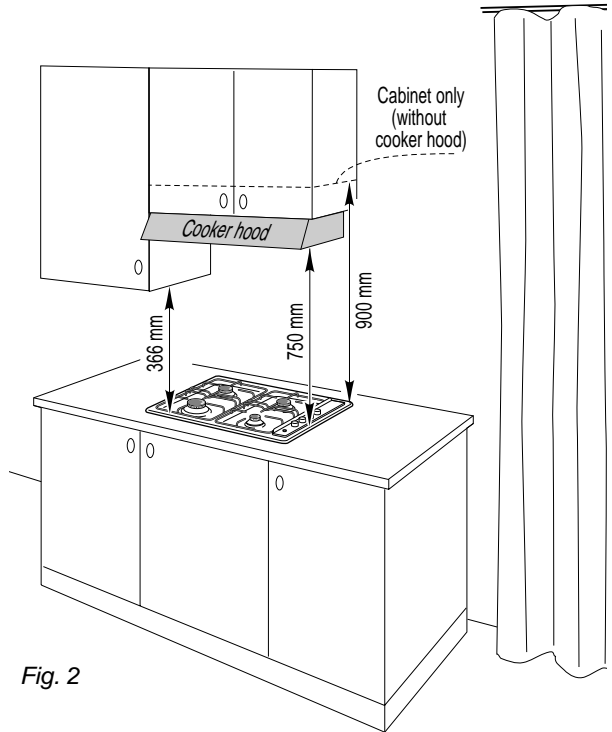

Fig. 2

Ventilation

All rooms require a window which can be opened or equivalent, while some rooms require a permanent vent in addition to a window.

This unit must not be used in a room with less than 5 m³.

Room Volume	Air vent necessary (effective area)
5 m ³	100 cm ²
5 m ³ to 10 m ³	50 cm ²
Greater than 11 m ³	No air vent necessary
A room 5 m ³ to 10 m ³ with a door opening to the outside	No permanent air vent necessary

The above requirements allow use of a gas oven and grill but if there are other fuel burning appliances in the same room BS5440 part 2: 1989 (ventilation) should be consulted to determine the necessary air venting requirements.

Installation

1. The hob requires a space in the kitchen work surface as shown in fig 3.

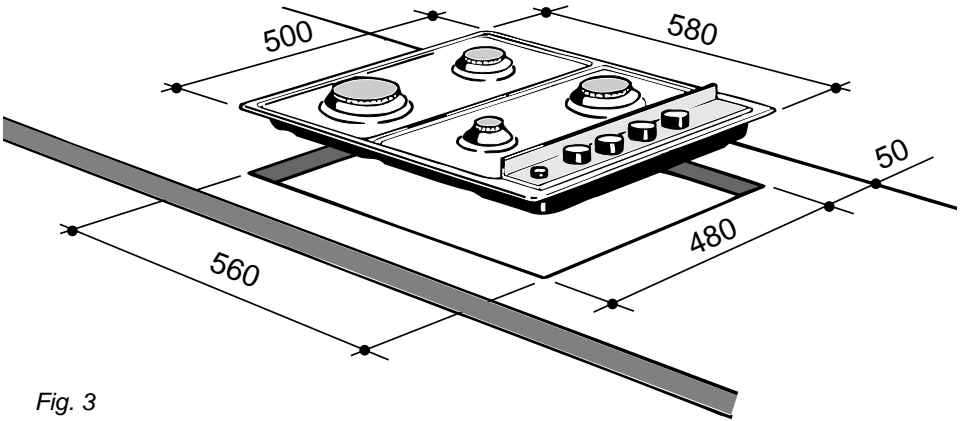

Fig. 3

NOTE: A partition between the base of the hob and the cupboard below should be fitted 100 mm below the worktop if the cupboard is to be used for storage. Never place perishable foods in the cupboard below the hob.

2. Apply the adhesive seal around the edge of the hob, making sure that the ends do not overlap or leave a space (fig. 4).
3. Attach the hob to the worktop using the brackets supplied as indicated in figure 5.
4. Tighten carefully.

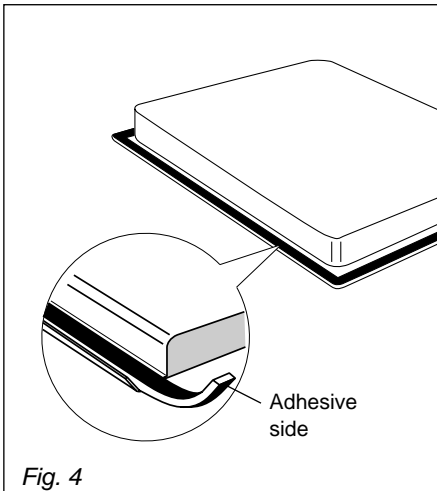

Fig. 4

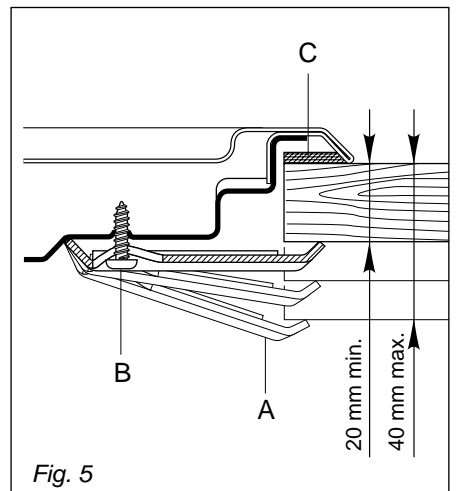

Fig. 5

How to use your gas hob

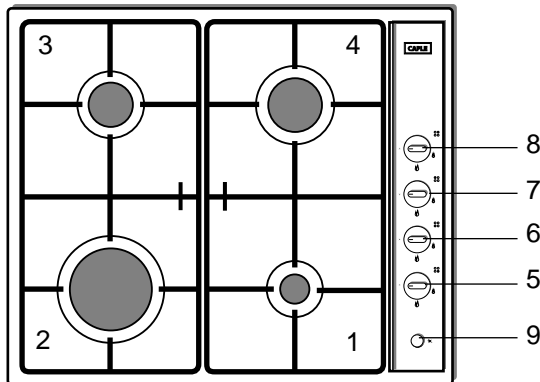

Fig. 6

BURNERS

1. Auxiliary burner
2. Rapid burner (R1)
3. Semi-rapid burner (SR)
3. Rapid burner (R2)

CONTROL PANEL

5. Burner 1 (A) control knob
6. Burner 2 (R1) control knob
7. Burner 3 (SR) control knob
8. Burner 4 (R2) control knob
9. Electrical ignition push button

- Check that the electricity is switched on to allow spark ignition.
- Make sure that all controls are turned to zero.
- The gas flow to the burner is controlled by a knob operating on a safety tap. You control the flow by turning the knob indicator to line up with the following symbols:

symbol  : Off

symbol  : Maximum

symbol  : Minimum

- To ignite, simply push the required knob down and turn it to maximum, then press ignition continuously until the burner lights.
When the flame is lit, you can control the temperature with the control knob.
- To switch off, turn the knob clockwise until you hear the safety click.
- Please note that, if you are using a burner at the minimum setting, you turn the knob clockwise past the maximum setting before reaching the off position.

How To Use Your Gas Hob

Cooking hints

The burners are different sizes, and can be used in different ways; the largest for boiling, to seal meat or foods that are cooked quickly and the smallest for stews and sauces.

Always ensure that you use the correct size of saucepan.

For fast boiling, make sure that the flame just reaches the edge of the pan.

Flames going up the side of the pan means wasted heat and the contents of the pan will take longer to boil.

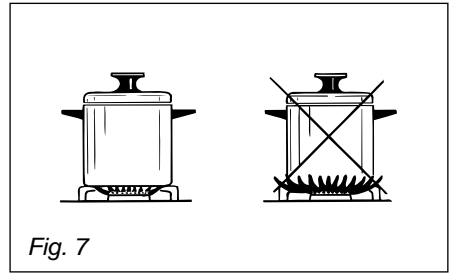

Cleaning your hob

Your gas hob has an enamelled finish, so you should use a non-abrasive cleaner.

An abrasive cleaner will scratch the surface and could erase the control markings.

Cream cleaners may clog the holes in the burners. When cleaning, ensure that these holes are kept clean and free from debris. Failure to do so will result in poor flame pattern and possible scorching of cooking utensils.

Remember to let the hob cool down before you clean it.

Troubleshooting

If you acquire a problem with your hob, check the following points before calling an engineer.

1. The power is switched on.
2. The controls are switched on.
3. Both the fuse and the mains fuse are intact.
4. The gas supply is connected to the appliance.

Should you still require an engineer then call the CAPLE Helpline on 01245 322770.

CAPLE “Built-in” Service

Should you require service at any time, please contact the **Caple Helpline on 01245 322770**.

Caple have a nationwide service network of engineers who will respond quickly to your call.

Always replace spare parts with genuine **Caple** spares. These are available from authorised **Caple Service Centres** or by mail order from our **National Service Stores, simply telephone 01245 322770**.

When ordering parts always quote the model number and serial number of your appliance.

YOUR GUARANTEE

CAPLE guarantees all parts of this product for one year from the date of purchase. During that time, should it become necessary CAPLE engineers will replace or repair all defective parts free of charge, except for parts subject to fair wear and tear, such as lightbulbs.

Parts and the engineers labour costs are chargeable after the first 12 months.

To qualify for benefits under the guarantee, you must be able to provide proof of date of purchase and the appliance must have been supplied, installed and used for domestic purposes only in accordance with CAPLE instructions.

Consequential losses and accidental damage to the product are not covered by the guarantee.

This guarantee does not affect your statutory or common law rights.

CAPLE cannot be responsible for the results of using this appliance for any other purposes other than those described in these instructions.