



C611E/GRN

Caple Liberty Electric Hob Green

TECHNICAL INFORMATION

C 611E/GRN

P630CP0517

tav. 1

cat. 18.P1977

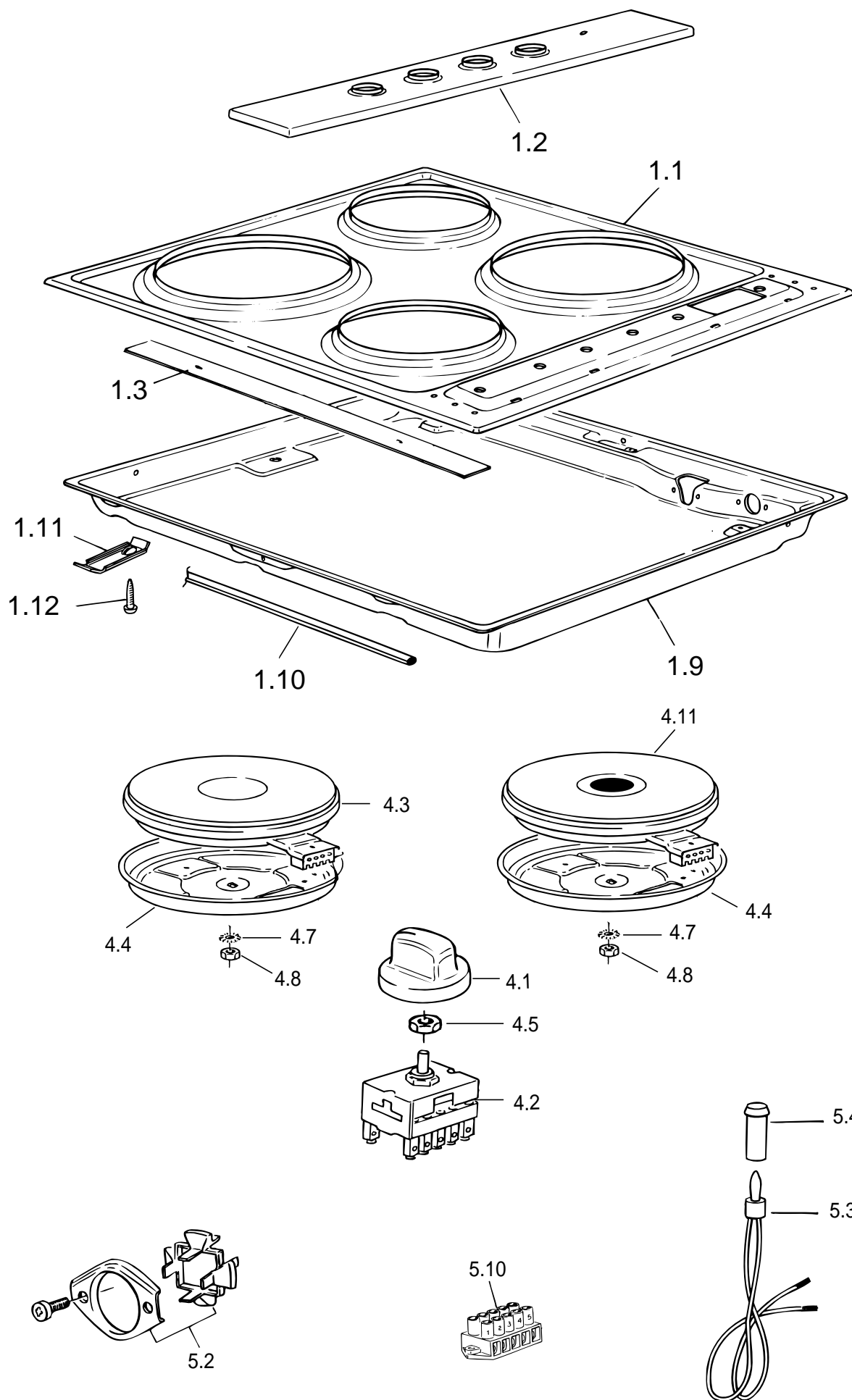

REF.	CODE	DESCRIPTION
1.1	331630417	Hob top
1.2	35P18867C2	Control panel
1.9	4116321	Burner casing
1.10	053026	Seal
1.11	094154	Fixing bracket
1.12	001130	Screw
1.13	58B6303	Bar
4.1	2185C02291	Knob (Black)
4.2	050033	Normal/rapid electric plate switch
4.3	04706230	Normal electric plate - Ø 145 - 1000 W - 230 V
=	04703230	Normal electric plate - Ø 180 - 1500 W - 230 V
4.4	103084R	Normal/rapid plate protection - Ø 145
=	103081R	Normal/rapid plate protection - Ø 180
=	58B6301	Normal plate protection - Ø 180
4.5	214063	Nut
4.7	003020	Washer
4.8	214027	Nut
4.11	04764230	Rapid electric plate - Ø 145 - 1500 W - 230 V
=	04765230	Rapid electric plate - Ø 180 - 2000 W - 230 V
5.2	052001	Wire fastener
5.3	073022	Control lamp L 270
5.4	073023	Control lamp cover
5.10	051025	Terminal block
-	113621	Wiring
-	1101799	Instruction booklet

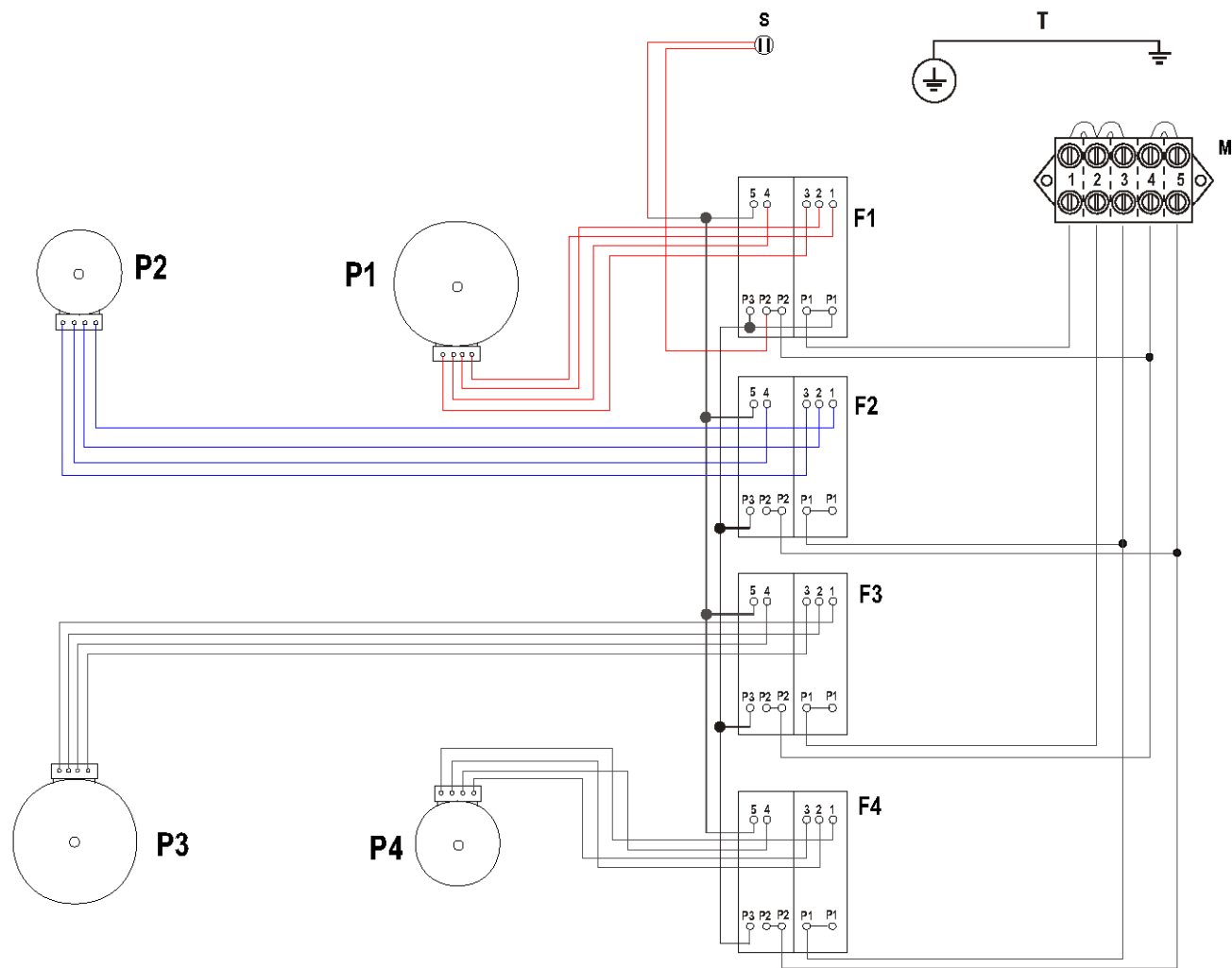

ELECTRIC DIAGRAM KEY

- F1\F4 Electric plates changers
- P1 Electric plate 2000W-230V
- P2 Electric plate 1000W-230V
- P3 Electric plate 1500W-230V
- P4 Electric plate 1500W-230V
- S Pilot lamp
- M Terminal block
- T Earth connection



C611E/GRN

Cable Liberty Electric Hob Green