

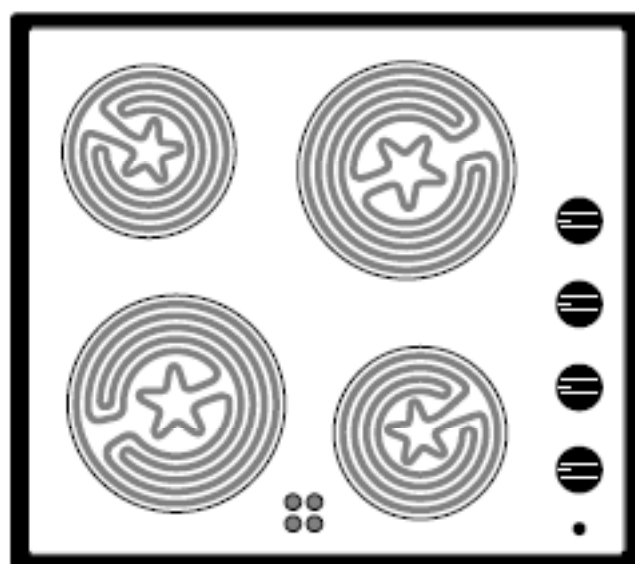

C801C/W

Caple Ceramic Hob White



TECHNICAL INFORMATION

Mod.: "C 801 C/B, C 801 C/W"

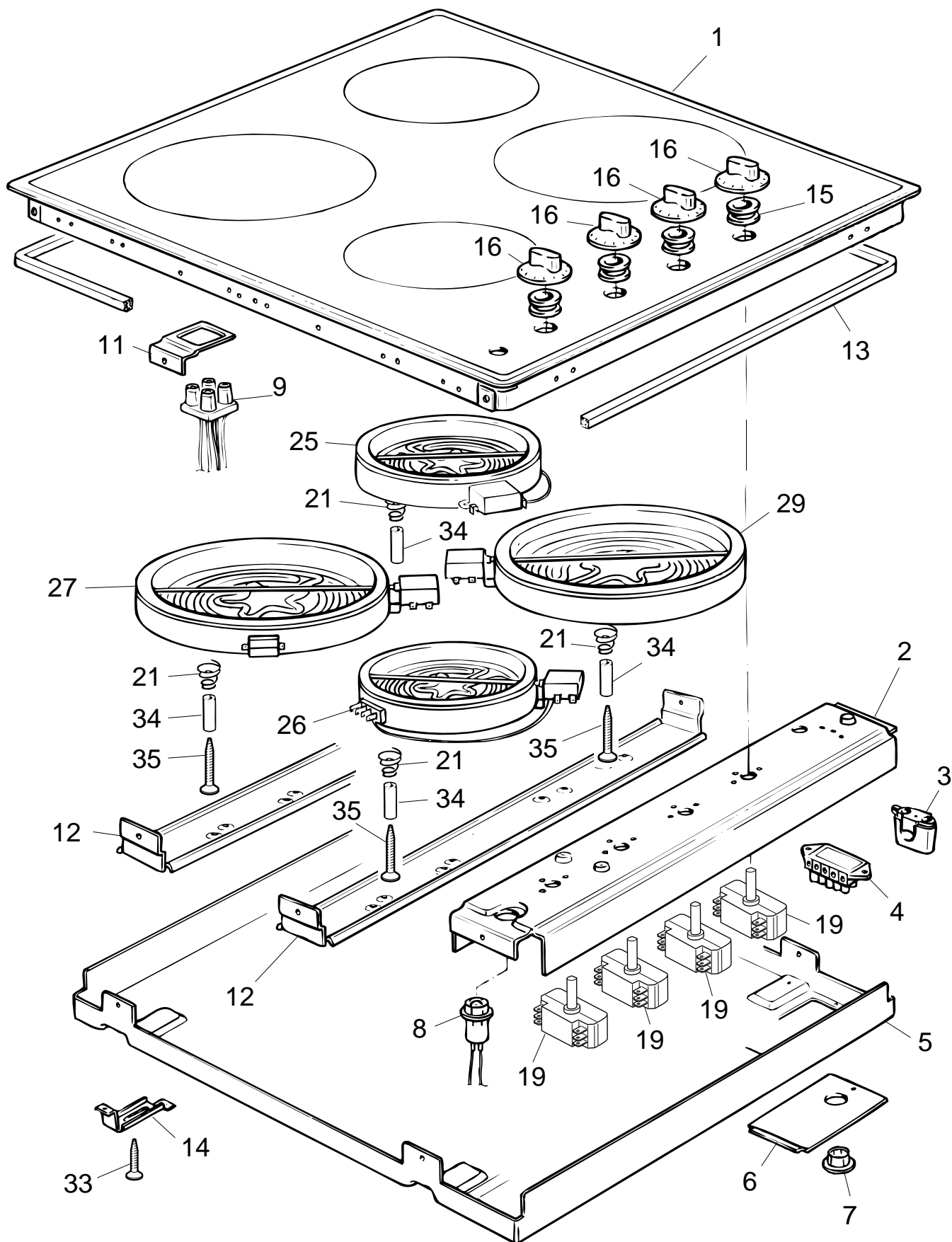

VITROCERAMIC HOBS

Mod.: "C 801 C/B, C 801 C/W"

<u>REF.</u>	<u>CODE</u>	<u>DESCRIPTION</u>	
1	355VC40	Glass with frame - Mod. C 801 C/W	
=	355VC41	Glass with frame - Mod. C 801 C/B	
2	51BCV01	Control support	
3	052006	Wire fastener	
4	051025	Terminal block	
5	411VC01	Casing	
6	51BVC03	Shield	
7	052007	Wire ring	
8	073026	Control lamp	
9	073027	Control lamp	
11	094112	Control lamp support	
12	51BVC02	Hotplates support	
13	053042	Seal	
14	094117	Bracket	
15	040027	Rubber ring	
16	218X923075	Commutator knob (White)	
=	218X925075	Commutator knob (Brown)	
19	050039	Commutator	
21	035075	Spring	
25	04713230I	Quick-light star hotplate Ø 145 - 230V - 1200W	
26	04714230I	Quick-light star hotplate Ø 145 - 230V - 1200W	
27	04718230I	Quick-light star hotplate Ø 195 - 230V - 1900W	
29	04716230I	Quick-light star hotplate Ø 180 230V - 1700W	
33	001053	Screw	
34	085043	Sleeve	
35	001111	Screw	
–	110928	Instruction booklet	113393/E Wiring

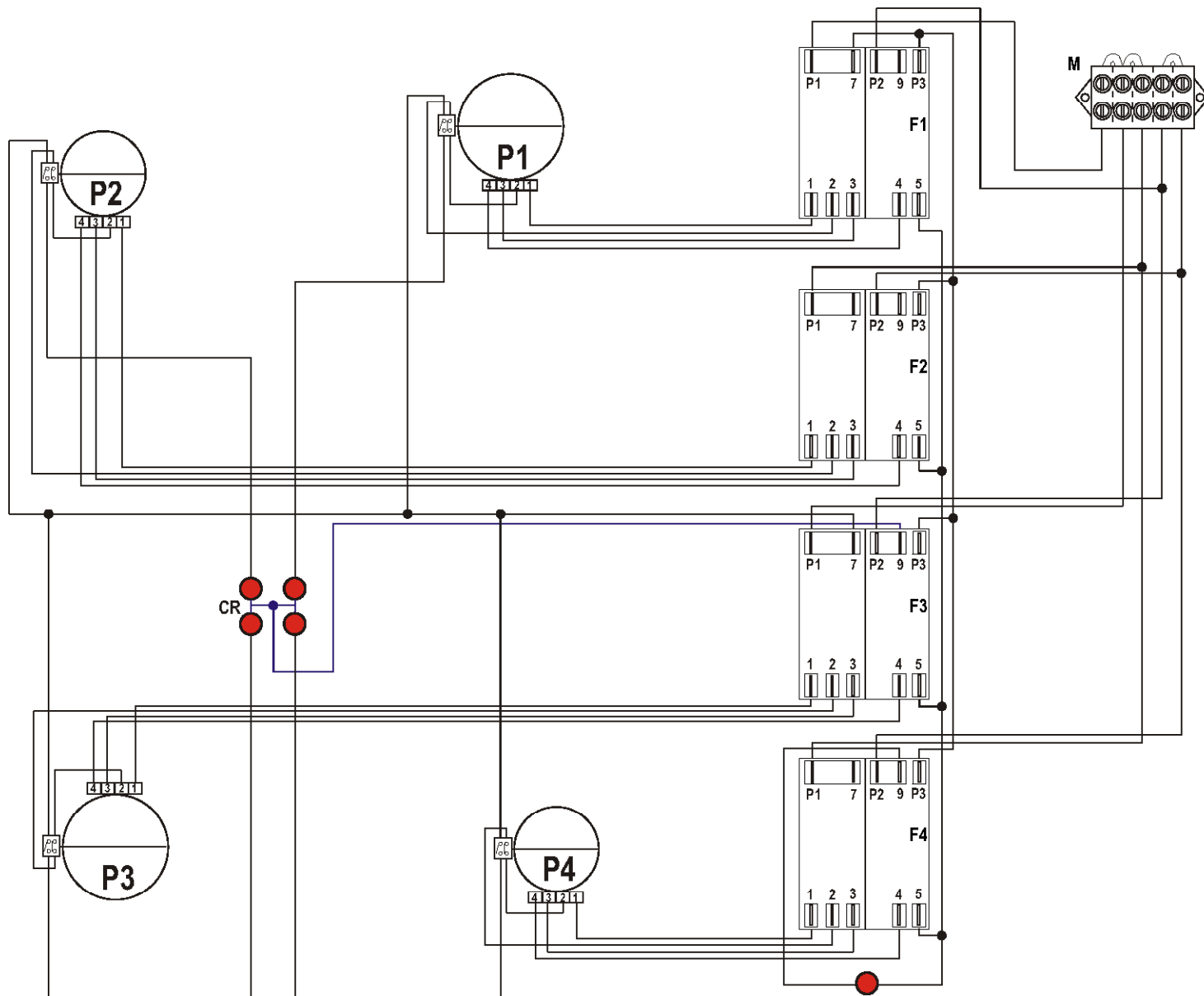

ELECTRIC DIAGRAM KEY

- F1/F4 Radiant plates switches
- P1 Radiant plate 1900W-3C-230V
- P2 Radiant plate 1200W-3C-230V
- P3 Radiant plate 1700W-3C-230V
- P4 Radiant plate 1200W-3C-230V
- S Pilot lamp
- M Terminal block
- GS Residual heat lamps



C801C/W

Caple Ceramic Hob White