



CM465SS

Caple Built-in Coffee Machine Stainless Steel



Technical Manual

## CM465SS Caple Built-in Coffee Machine

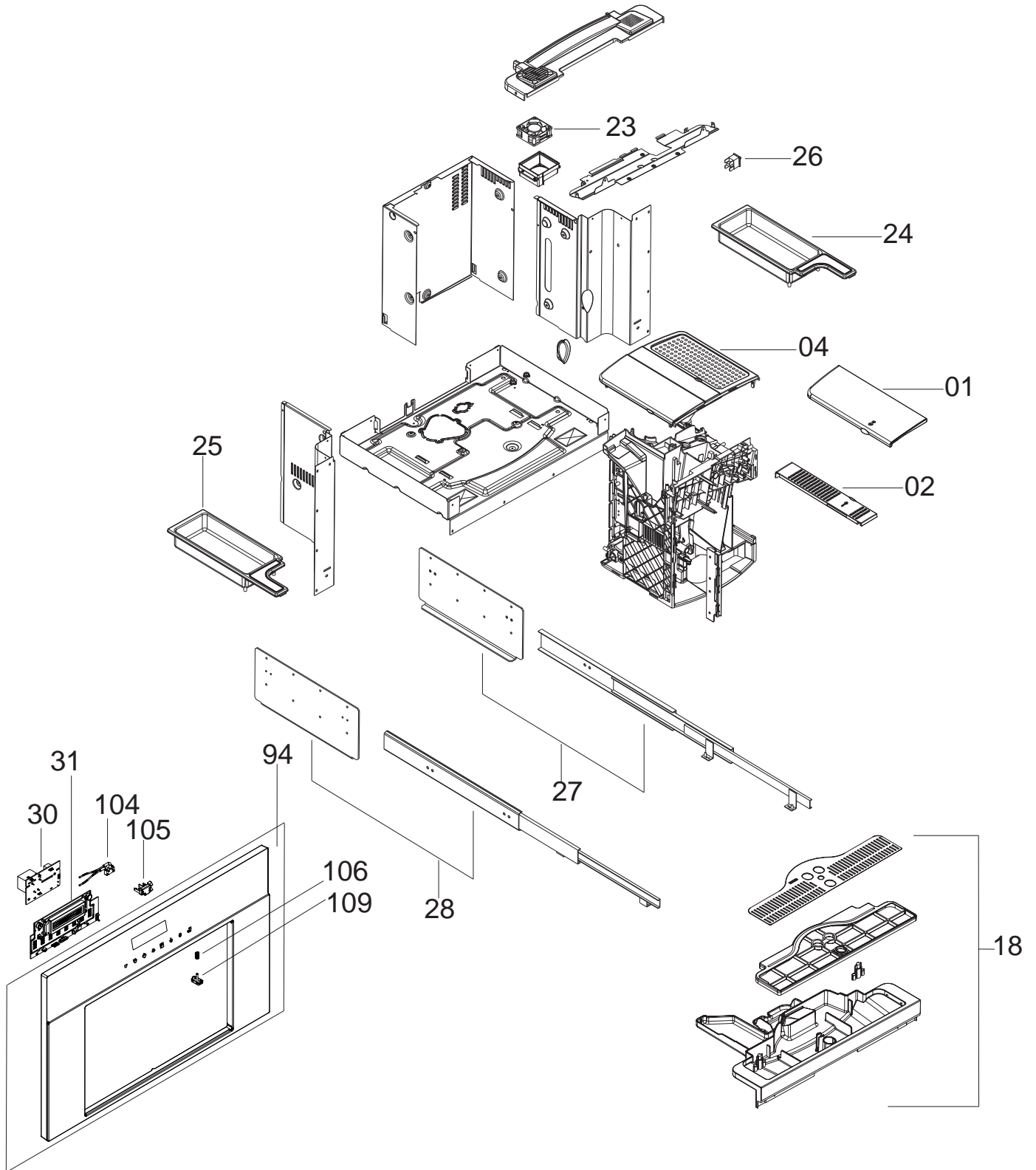



CM465SS Caple Built-in Coffee Machine

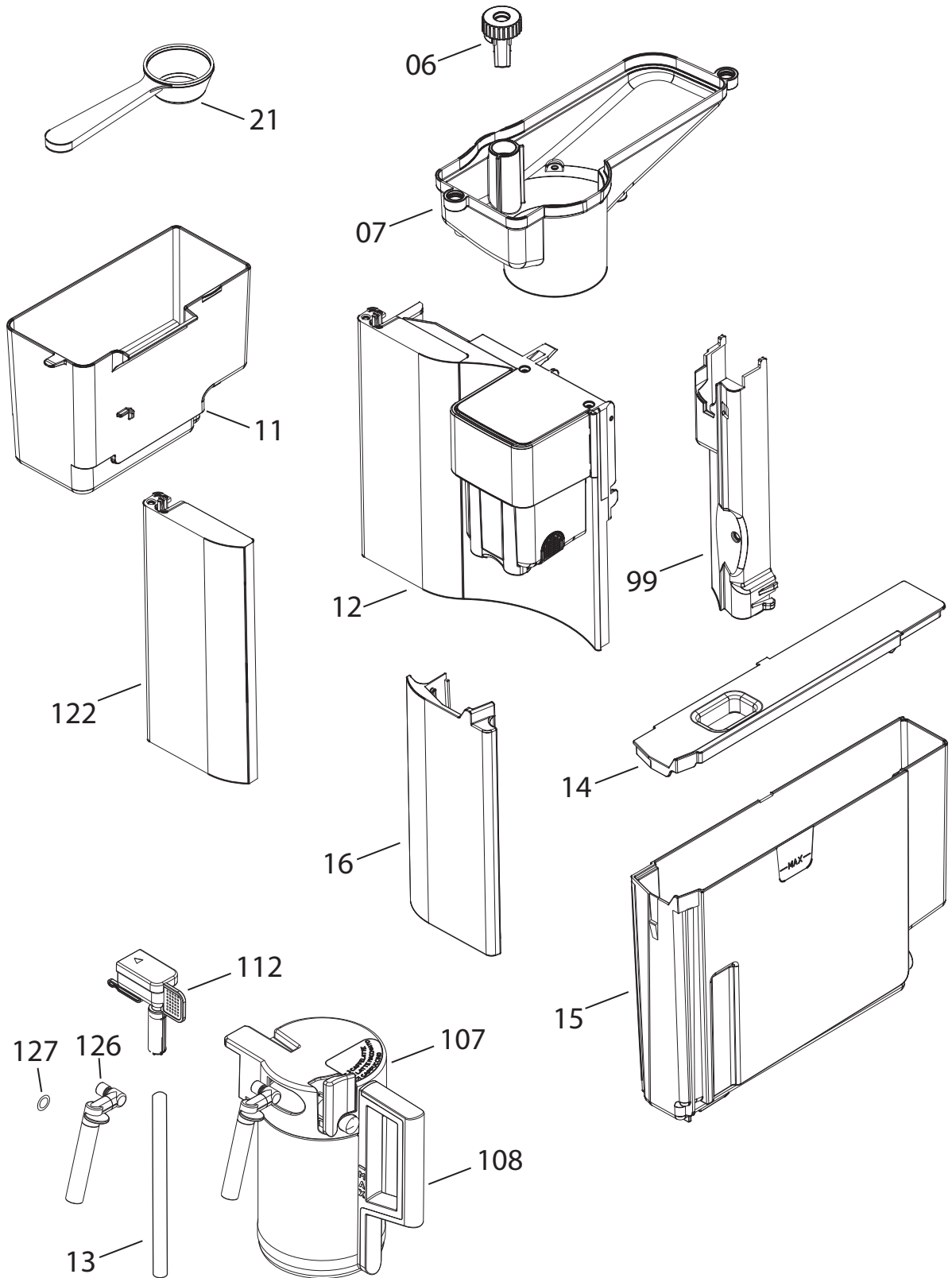

## CM465SS Caple Built-in Coffee Machine

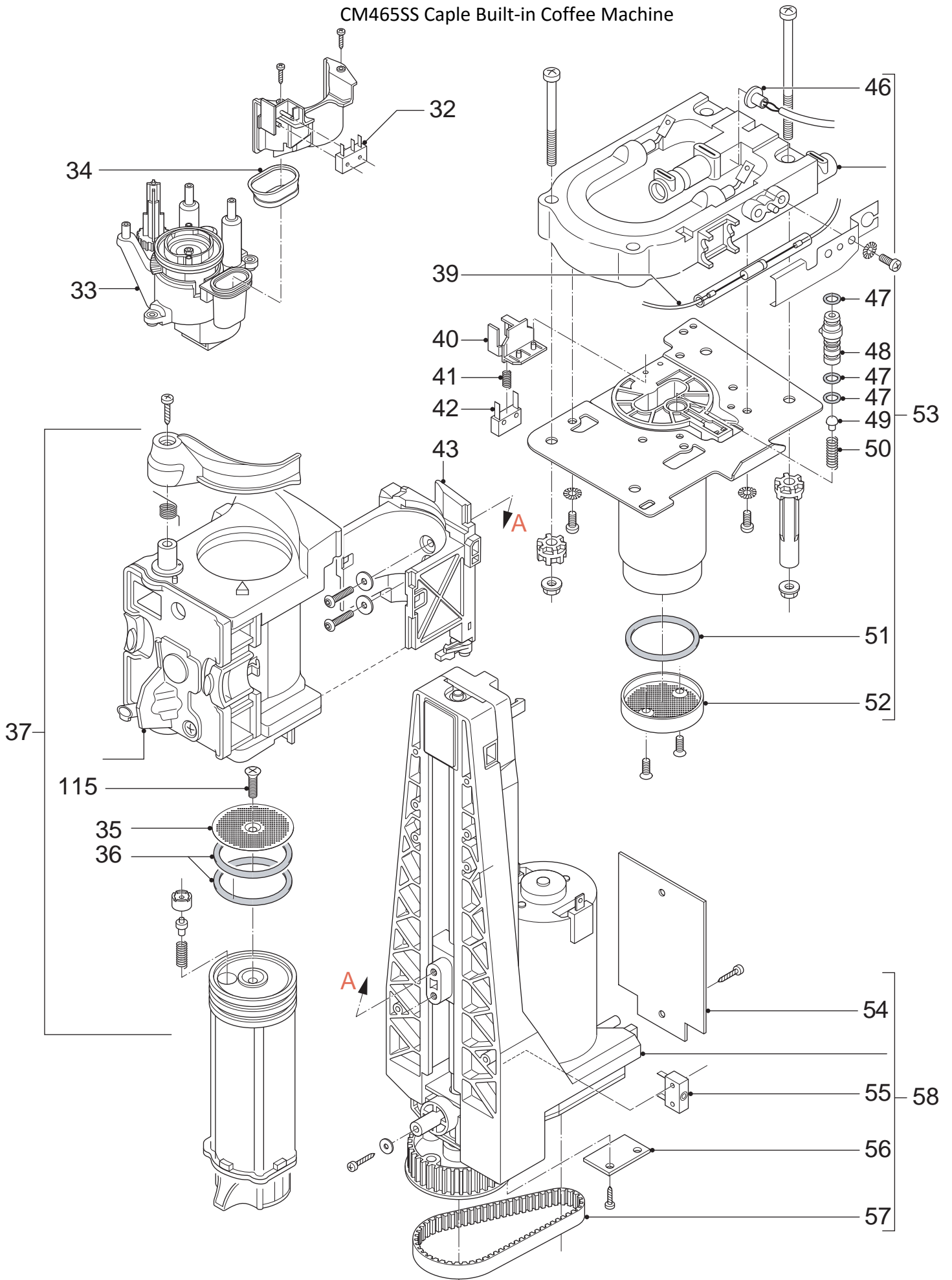

TUBE SERIES

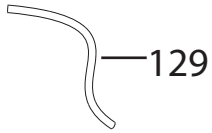

CM465SS Cagle Built-in Coffee Machine

TUBE SERIES WITH BUSHES

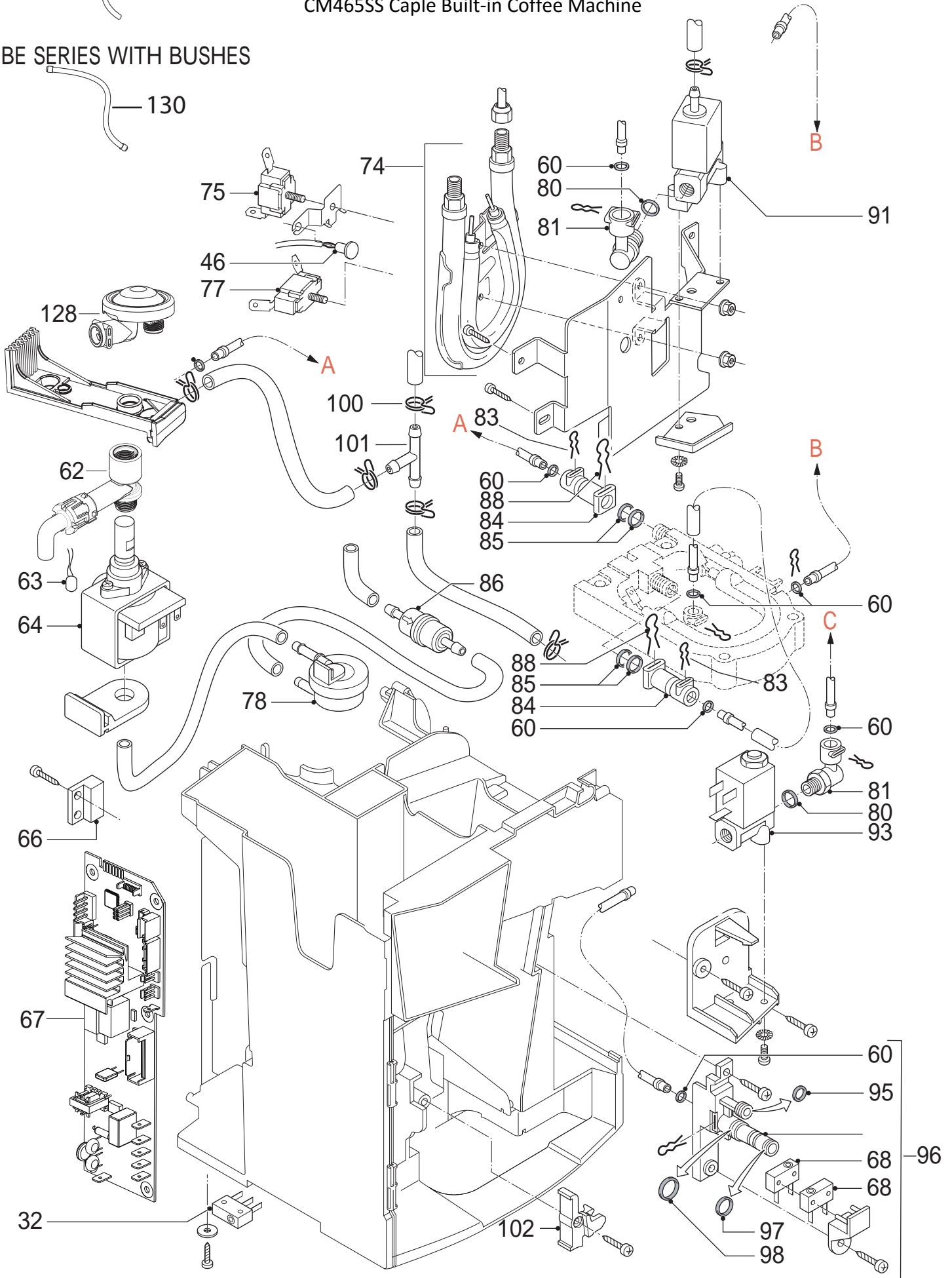
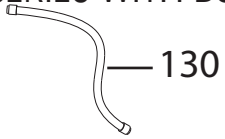



## CM465SS Caple Built-in Coffee Machine

Position	Part Number	Description
0	5513216661	POWER SUPPLY CORD SCHUKO
001	5332143500	COVER
002	5332143400	COVER
004	5332262600	CLOSURE
006	5913210471	KNOB
007	5513220281	TANK
011	5313228721	TRAY
012	7313233391	DOOR ASSY
013	5332234800	TUBE
014	5332226800	TANK COVER
015	7332199300	WATER TANK
016	5332248500	PROFILE
018	7313247071	PAN ASSY.
021	5332107900	MEASURING SPOON
023	5113210191	VENTILATOR
024	5332248800	TRAY
025	5332248900	TRAY
026	5132112500	SWITCH
027	7332222300	RUNNER RIGHT
028	7332222400	RUNNER LEFT
030	5213211031	BOARD LED
031	5213220181	BOARD DISPLAY
032	5132105400	MICROSWITCH
033	7313230461	COMPLETE GRINDER
034	5332144900	GASKET
035	6013213181	FILTER (TAI-FENG)
036	5332149100	O-RING
037	5513227911	INFUSION KIT
038	5032526800	WIRING TCO
039	5032526900	WIRING TCO
040	5332142200	SUPPORT
041	6132104700	SPRING
042	5132104100	MICROSWITCH
043	7332166600	SLIDER
046	5217100200	SENSOR NTC
047	5313217751	O-RING
048	5332213000	PIN



CM465SS Caple Built-in Coffee Machine

049	5332148400	VALVE
050	6132106900	SPRING
051	5332149100	O-RING
052	5332139200	FILTER
053	5513227901	GENERATOR
054	5213220501	MOTOR BOARD (CHIAPHUA)
055	5132110500	MICROSWITCH
056	5213213971	HALL SENSOR
057	5313243071	BELT
058	7313250251	TRANSMISSION KIT (CHIAPHUA)
060	5313217701	O-RING D=3,85
062	7313219421	VALVE
063	5213211801	PROTECTOR
064	5113211281	PUMP
066	5232104600	SENSOR REED
067	5213216501	POWER BOARD
068	5132104100	MICROSWITCH
074	5513227931	VAPORIZER KIT
075	5232105000	TCO
077	5232105000	TCO
078	5213214671	FLOWMETER
080	5313217741	O-RING
081	5313218341	CONNECTION
083	6132101300	CLIP
084	5332239200	CONNECTOR
085	5313228791	GASKET
086	5513220521	FILTER
088	6113210021	CLIP
091	5213218471	SOLENOID VALVE
093	5213218321	SOLENOID VALVE
094	N/A	FRAME ASSEMBLY
095	5332196000	O-RING
096	5513214821	COUPLING CARAFE
097	5313217751	O-RING
098	5332177500	O-RING
099	5332249200	COVER
100	9824800009	CLIP CLAMP
101	5313216541	CONNECTION



CM465SS Caple Built-in Coffee Machine

102	5332142600	HOOK
104	5132114100	SPRING MICROSWITCH
105	5313215881	SUPPORT
106	6113210261	SPRING
107	7313245221	COVER ASSEMBLY
108	7313229391	CARAFE
109	5313215901	BUTTON ON/OFF
112	5513212801	PIPETTE
115	9812631250	SCREW
122	5313215541	FRONT PIECE
126	5532144200	TUBE DISTRIBUTING
127	5332144800	O-RING D=6
128	5513211371	REGULATOR
129	5332178100	TUBE (SIL NAT)DI=4 L=270
129	5332110600	TUBE (SIL NAT)DI=4 L=220
129	5332111500	TUBE (SIL NAT)DI=7 DE=10 L=120
129	5332115400	TUBE (SIL NAT)DI=5 L=145
129	5332177800	TUBE (SIL NAT)DI=4 L=200
130	5513219841	TUBE PTFE L=135 NUT 1BUSHE
130	5513213821	TUBE PTFE DI2-DE4 L=170 2BUSHES
130	5513213501	TUBE PTFE DI2-DE4 L=150 2BUSHES
130	5513212881	TUBE PTFE DI2-DE4 L=270 2BUSHES
130	5513213801	TUBE PTFE DI2-DE4 L=180 2BUSHES
130	5513219851	TUBE PTFE L=335 NUT 1BUSHE

# SERVICE TRAINING COURSE

## CAPLE CM465/CM465GM/CM465SS



# Contents

---

- ❖ **INTRODUCTION**
- ❖ **KEY FEATURES**
- ❖ **MACHINE DESCRIPTION**
- ❖ **TECHNICAL DATA**
- ❖ **WATER CIRCUIT**
- ❖ **MAIN COMPONENTS**
- ❖ **TEMPERATURE MEASUREMENT**
- ❖ **WIRING DIAGRAM**
- ❖ **DIAGNOSTIC / TROUBLESHOOTING**
- ❖ **MAINTENANCE**

---

# Introduction

# Introduction

---

This document is aimed to provide useful technical informations about appliances to authorized engineers. Is always required to operators, to follow these preliminary steps before proceed any other operation:

1. Verify the nameplate, check the serial number to deduce the age of the appliance ;
2. Check and download the documentation on <http://dls.delonghigroup.com/> (DLS site);
3. Now you can access to user manual and (if present) service manual and technical bulletins (is always suggested to check all these documents);
4. Remove the infuser and check the piston movement to ensure it's not stuck, if is ok, put it into the machine again, if isn't, check "infuser cleaning" in this document, paragraph "maintenance";
5. Switch on the machine and access to the statistic mode (instructions are included in the manual) in order to understand how much the machine has been used;
6. Perform the load test mode in order to ensure that component are working correctly;
7. If a problem is found, check if any technical bulletin has been raised in DLS discussing about the same problem, otherwise check the troubleshooting included in this document

---

# Key Features

# Key features

---

- Control panel with direct selection keys for cappuccino, latte macchiato, caffelatte
- Removable, dishwasher-safe milk container, can be stored separately in the refrigerator
- Patented milk frothing system
- Vario regulator for milk foam consistency
- Additional milk frothing nozzle
- Removable low-maintenance brewing unit
- "Pre-brew" aroma system for perfect coffee enjoyment
- 250 g bean container
- Suitable for coffee beans and coffee powder
- Height-adjustable coffee spout and hinged drip tray for up to 15 cm high glasses
- Frontal removable 1.8 l water tank
- Removable drip tray with water level indicator
- Programmable shutdown



---

# Technical data

# Technical data

MAIN		
Voltage	V/Hz	220-240 /50/60
Absorbed power	W	1350
Pressure	Bar	15
Water tank cap.	Litres	1.8
Dimensions	L x H x P	282 x 374 x 441 mm
Weight	Kg	11.4
Cable length	m	1.45
COFFEE SECTION / SEZIONE CAFFE'		
Temperature probe	°C	98
Thermal fuse TCO	°C	192
Heating element	W	600 + 600 = 1200
Pump	TYPE	ULKA EPSGW- W 48
STEAM SECTION / SEZIONE VAPORE		
Temperature probe	°C	145
Thermal fuse TCO	°C	318
Heating element	W	1000
Pump	TYPE	ULKA EPSGW- W 48

---

# Machine Description

# Machine description

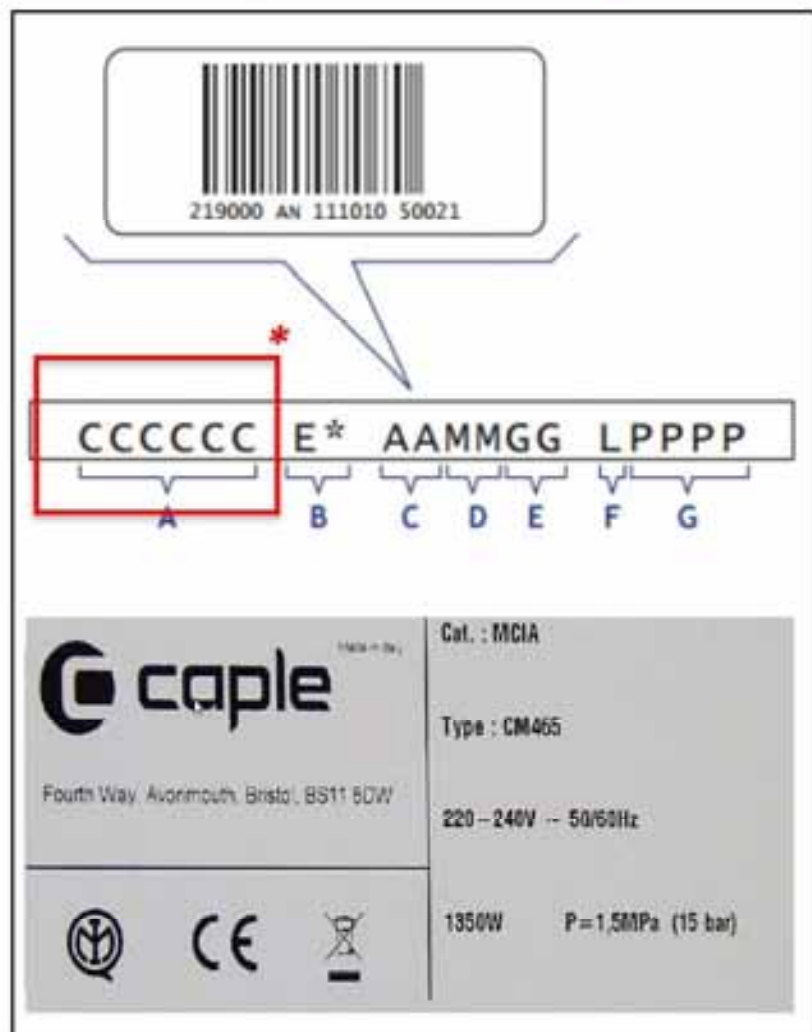

## HOW TO READ MACHINE'S NAMEPLATE

The identification labels for product recognition are affixed in the machine (see figure).

The serial number consists of 19 numbers that identify the machine:



- A. Last digits of the finished product SAP code
- B. 2-letter Execution Code
- C. Year of manufacture (last two digits of the year)
- D. Month of manufacture (e.g., 01= January, 02= February, etc.)
- E. Finished product day of manufacture
- F. Finished product assembly line
- G. 4-digit progressive number (e.g., 0001, 0002, 9999, etc)

# Machine description

219000 AN 111010 50021

CCCCCC E\* AAMMGG LPPPP

A B C D E F G

 Fourth Way, Avonmouth, Bristol, BS11 6DZ	Col. : MCIA
	Type : CM465
	220 – 240V – 50/60Hz
	1350W P=1,5MPa (15 bar)

## HOW TO READ MACHINE'S NAMEPLATE

Serial Number composition: ASSCC XXX AA Last digit of production year SS Production week CC Print date automatically calculated since 1992 (ex. production week fourth, production year 2003; the serial number will be: 30411) XXX Production site (ex. S02, S06, S08, etc.).

## HOW TO FIND THE EXACT MODEL IN DLS SITE:

Write in the search bar "0123" (de'longhi code for fully automatic coffee machines), followed by the first 6 numbers of the nameplate\* (for example 0132215111)

# Machine description

---

## DISPLAY



2. 'MENU' to activate or deactivate menu
3. 'RETURN' to exit the selected mode
4. 'Rinse'
5. 'SCROLL' to scroll forwards through the menu and display
6. 'COFFEE STRENGTH' to select strength or preground
7. 'SCROLL' to scroll backwards through the menu and display
8. Touch key to select the type/quantity of coffee (espresso, smallcup, medium cup, large cup, mug)
9. 'OK' to confirm the selected function
10. Touch key 'One cup of coffee'
11. Touch key 'Two cups of coffee'
12. Touch key 'Cappuccino'
13. Touch key 'Hot water deliver'

# Machine description

## PRODUCT OVERVIEW

- A. Main switch  
(Aa) - On / Off button
- B. Handles
- C. Nozzle
- D. Water tank (removable)
- E. Cup tray
- F. Drip tray grill (removable)
- G. Service door
- H. Height adjustable coffee dispenser
- I. Control panel
- J. Coffee bean holder cover
- K. Ground coffee chute cover
- L. Brewing unit
- M. Power cable
- N. Milk container:
  - N1. Cover (removable)
  - N2. Slider CAFFELATTE/CAPPUCCINO (removable)
  - N3. CLEAN button
  - N4. Milk dispenser pipe (removable)
  - N5. Suction pipe (removable)
- O. Hot water nozzle (removable)
- P. Measuring spoon for preground coffee
- Q. Waste coffee container (can be taken out)
- R. Knob for setting the grind level
- S. Coffee bean container
- T. Place for the measuring spoon
- U. Filling chute for preground coffee
- V. Coffee guide
- W. Place for accessories (left and right)
- X. IEC Connector
- Y. LED

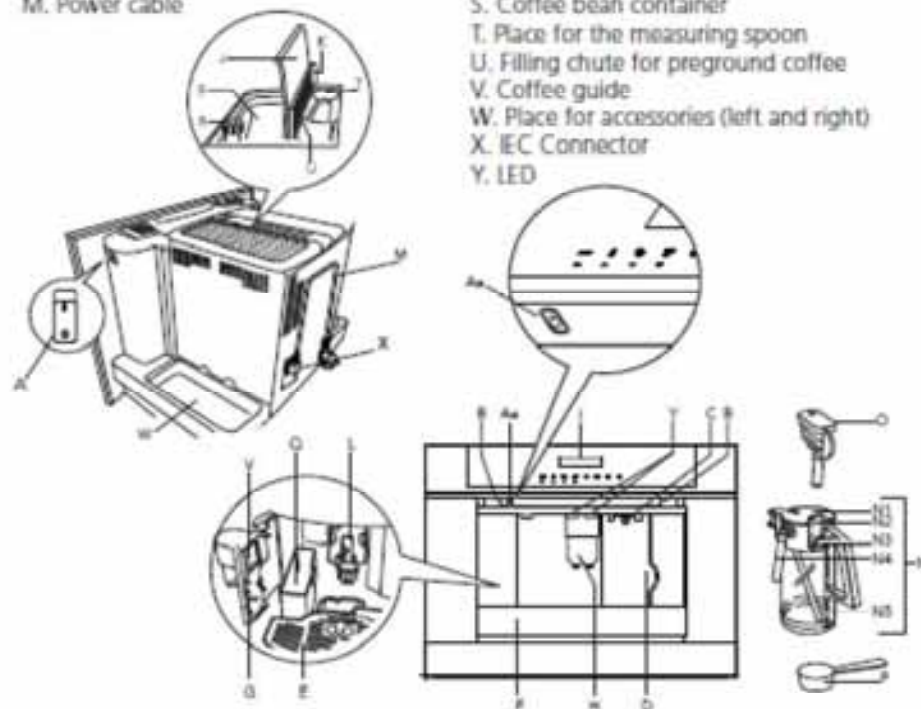

# Machine description

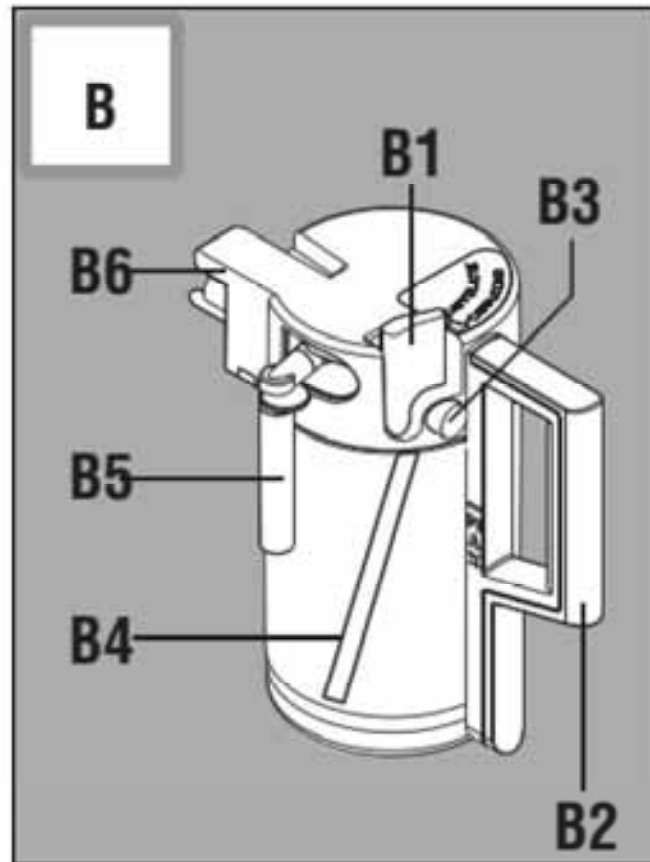

## ***MILK CONTAINER'S DESCRIPTION***

**B1. Froth regulator**

**B2. Milk container handle**

**B3. CLEAN button**

**B4. Milk intake tube**

**B5. Frothed milk spout**

**B6. Lid with milk frother**

# Machine description

---

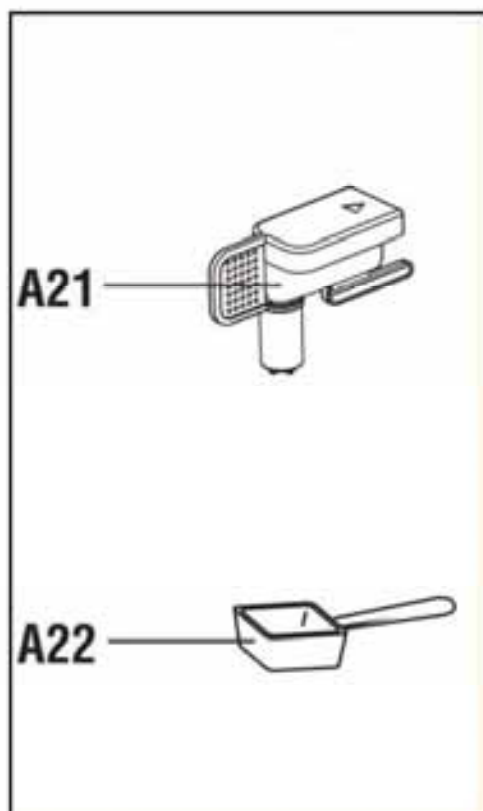

## ***ACCESSORIES DESCRIPTION***

**A21. Hot water spout**

**A22. Measure**

---

# Water circuit



# Water circuit

**STEAM**

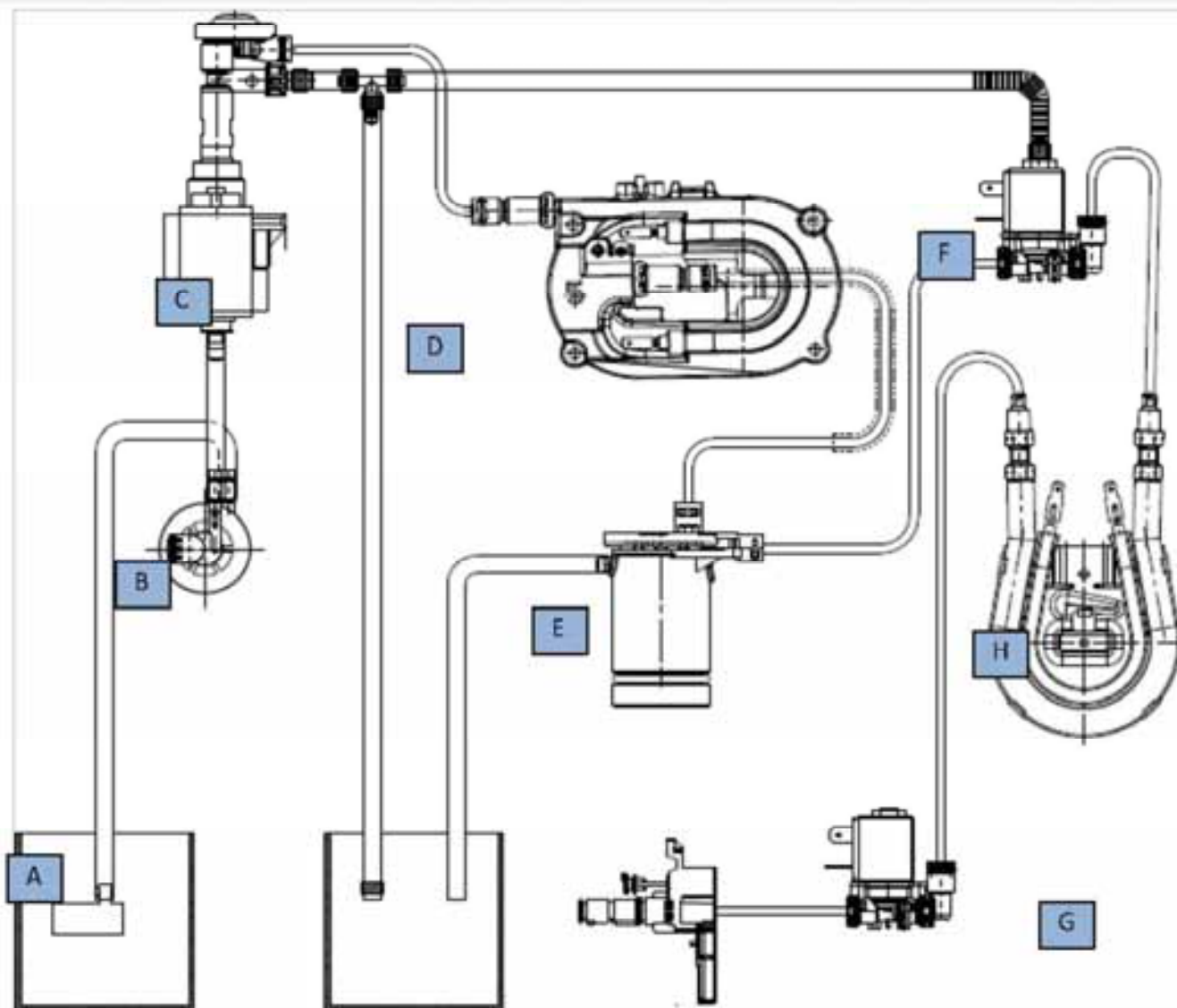

---

# Main Components

# Main components

## A WATER TANK:

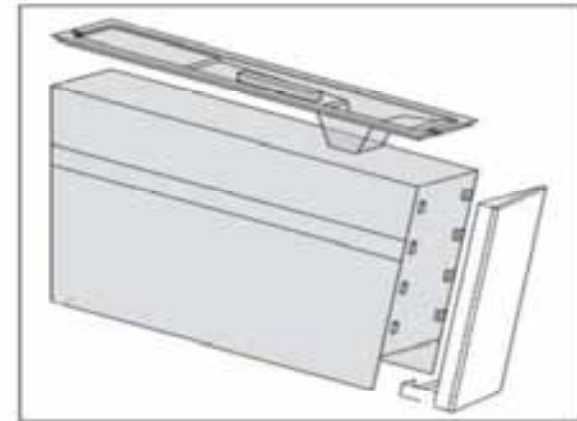
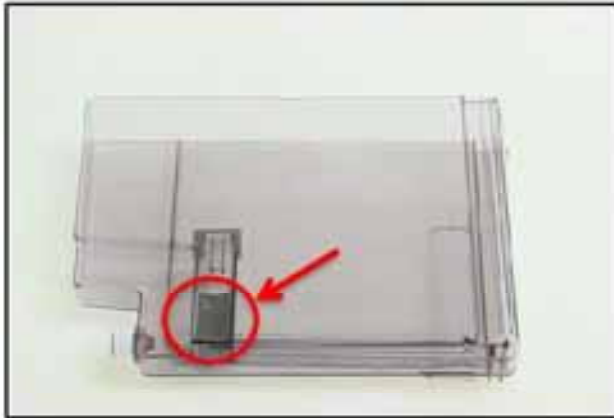

- Machine's tank have a capacity of 1.8 liters;
- It's equipped with a magnetic float (red circle, Pic.1) aimed to control the water level;
- In some models is possible to add a filter for water softening (Pic. 2) as explained in related manual

# Main components

## B FLOW METER

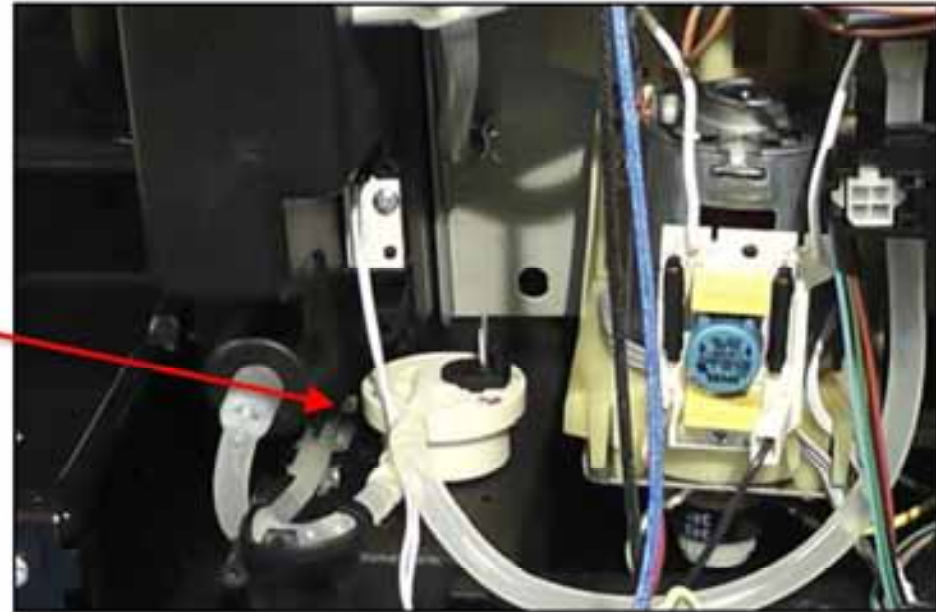

-This part allow the machine to calculate the quantity of water produced

-This calculation is executed by a sensor that read the magnetic impulses coming from the “mill” rotation, located inside it

-Is located between water tank (water filter, if included) and pump

# Main components

## C PUMP UKLA EP5

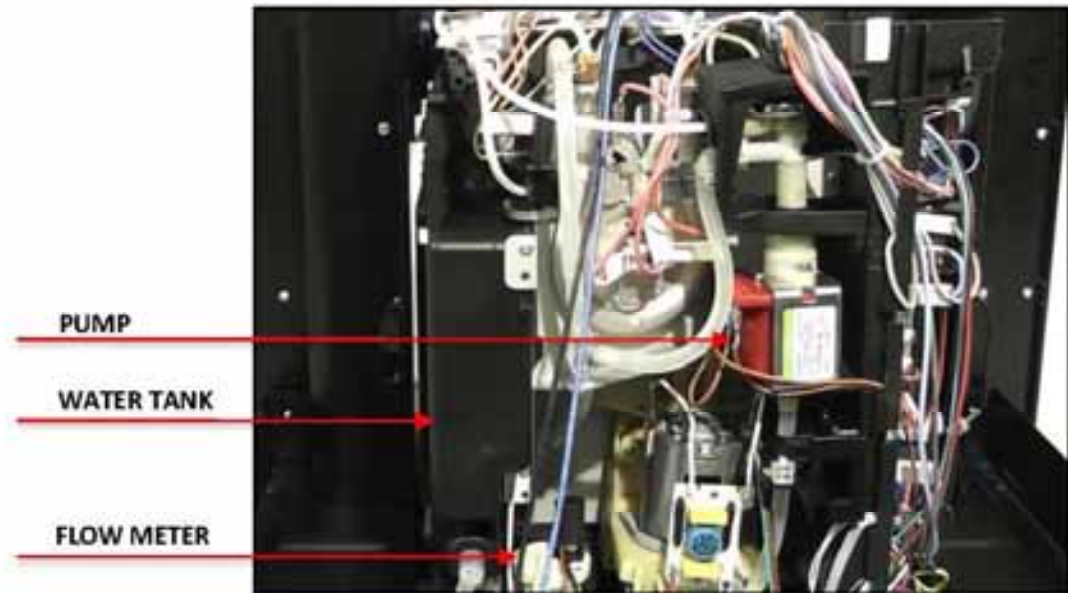

-Piston pump with maximum pressure 15 bar ( $\pm 10\%$ ), 230V-50 Hz;

COFFEE PRODUCTION: Pump is activated in a continuous mode,

STEAM PRODUCTION: Slow pulsing mode,

HOT WATER PRODUCTION: Fast pulsing mode,

-The pump is automatically activated for few seconds when the appliance is turned on, off or if a rinse is required from the user;

-Machine's equipped with auto pump priming function.

# Main components

## D GENERATOR (THERMOBLOCK)

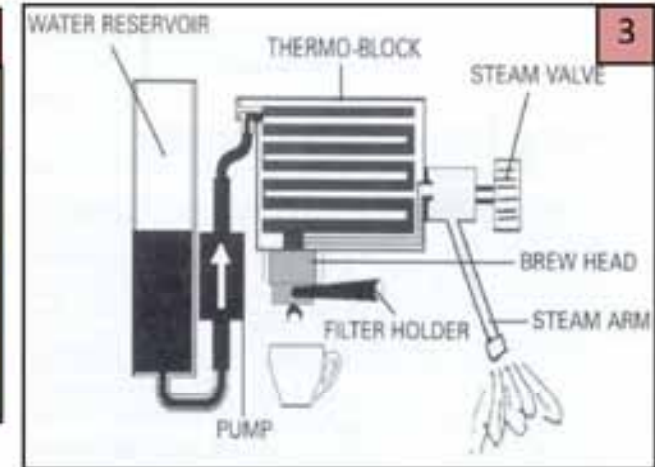
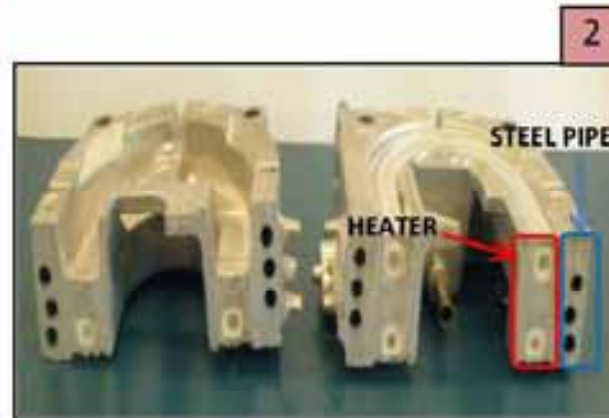
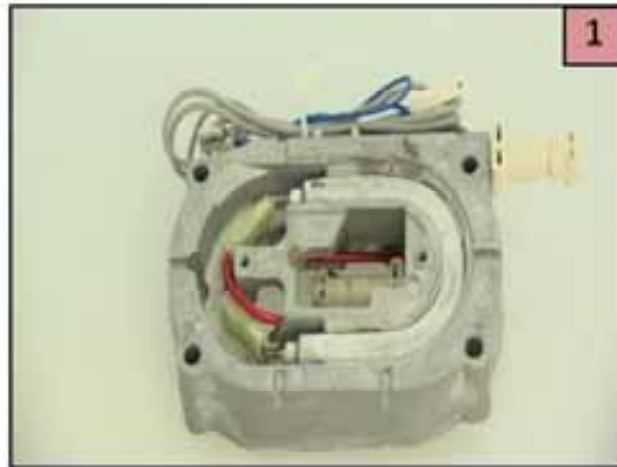

-Have an aluminium structure, It use a coiled piping in stainless steel material beside to 2 heating elements ( $600 + 600 = 1200W$ );

-Allow to better control the temperature's stability during coffee pouring;

-NTC probe is inserted in the body close to the thermo block's outlet (set:  $98^{\circ}C$ ), TCO is also present (set.  $192^{\circ}C$ );

-It need regular de-scaling procedure as maintenance.

# Main components

## E INFUSION KIT (MECHANICAL VALVE)

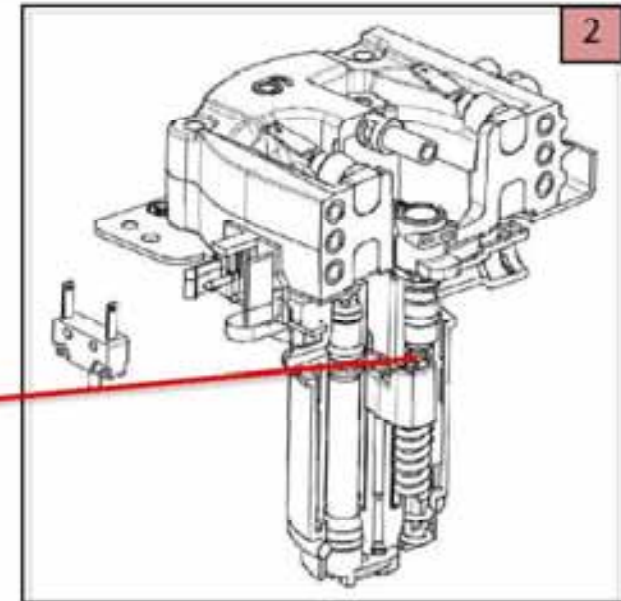
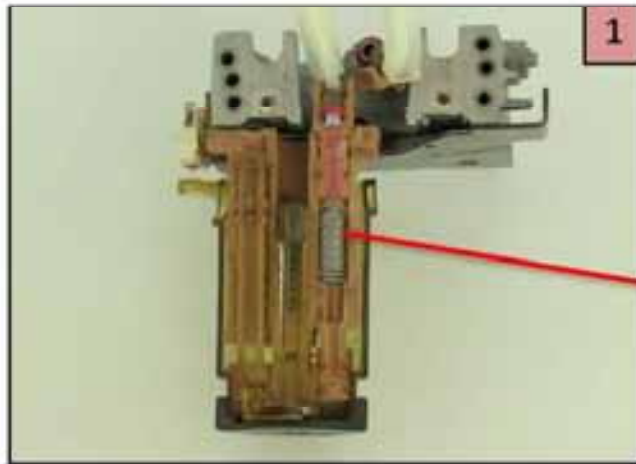

- The mechanical valve let possible the water pouring once the valve itself is pressed from the infuser;
- Stops the water flow when is in rest position and opens it when it's pressed;
- Circuit open to a discharge pipe once the infuser release the pressure to the valve;
- Water flow is also controlled by a valve which is frequently known as "mushroom valve".

# Main components

## E INFUSION KIT (MECHANICAL VALVE)

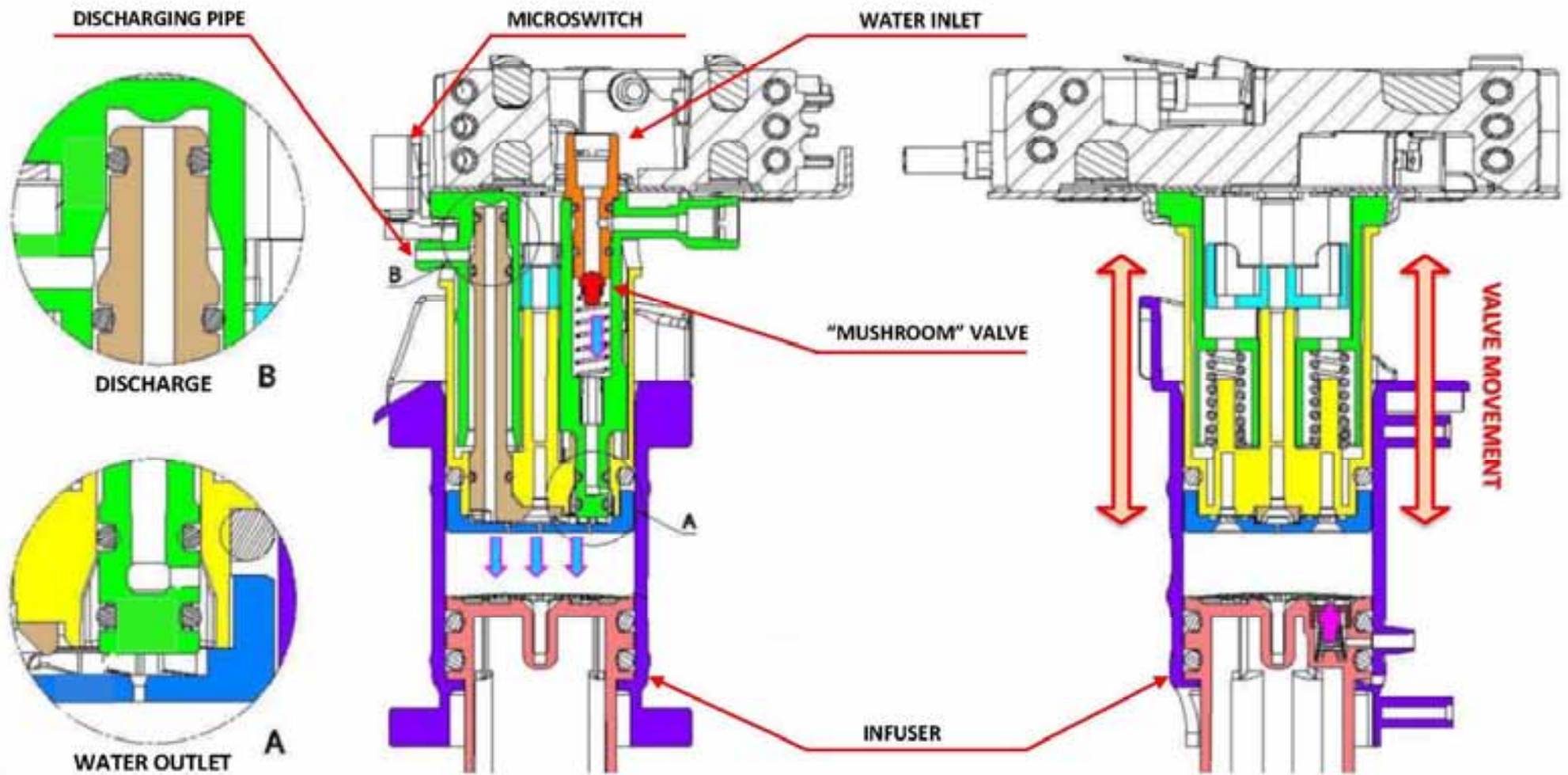

# Main components

## E INFUSION KIT (MECHANICAL VALVE)

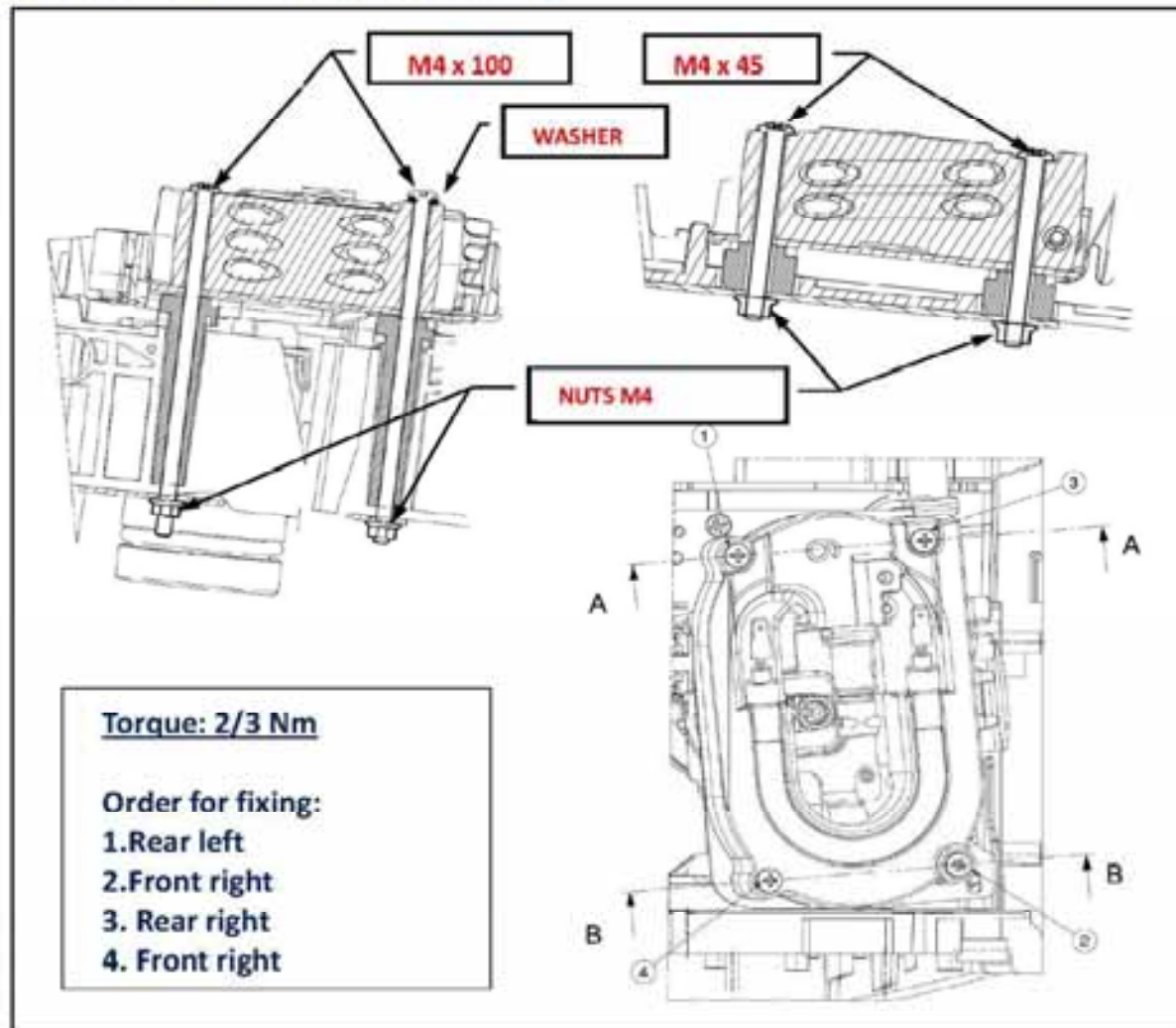

# Main components

## F G SOLENOID VALVES



-Solenoid valves could have 2 or 3 ways: inlet, outlet, discharge (only 3 ways), AC, 230V, 50Hz;

-Solenoid valves have the function to switch from a state to another, basing on the normal state of the valve;

-To make commutate the valves is necessary to provide alternate current to the solenoid;

-Is possible to verify its response using the auto diagnosis mode of the machine.

# Main components

## H GENERATOR (STEAM)

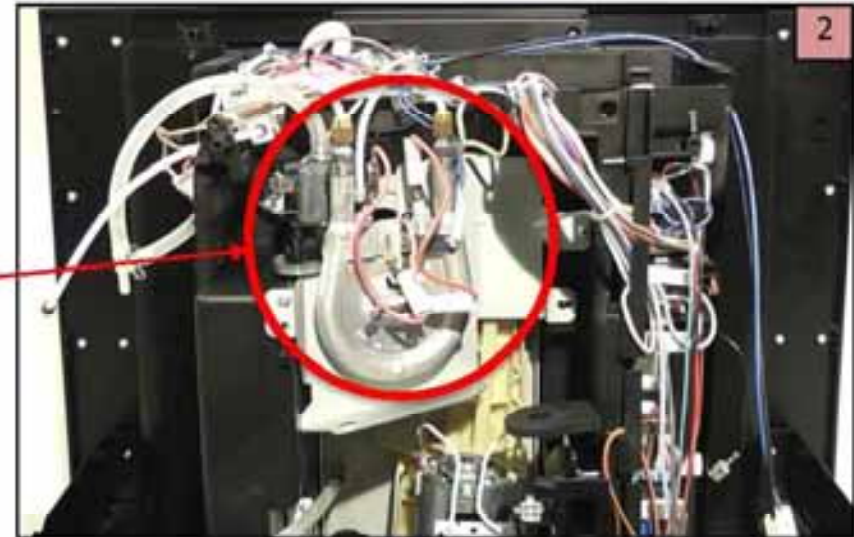

- 1000W , NTC setting : 145°C, TCO setting: 318°C;
- It's an independent boiler that Allow the preparation of cappuccino beverages in a much shorter timing respect to a single boiler machine;
- The steam circuit could be independent to the coffee circuit or integrated to it (basing on models);
- The double boiler makes the system more efficient but increases energy consumption.

# Main components

## TRANSMISSION KIT

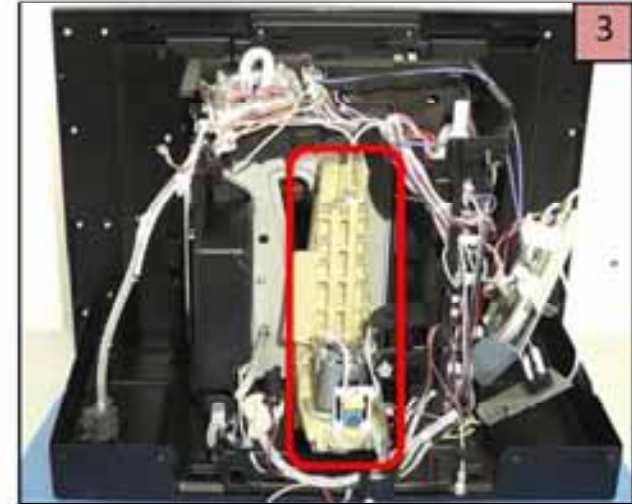
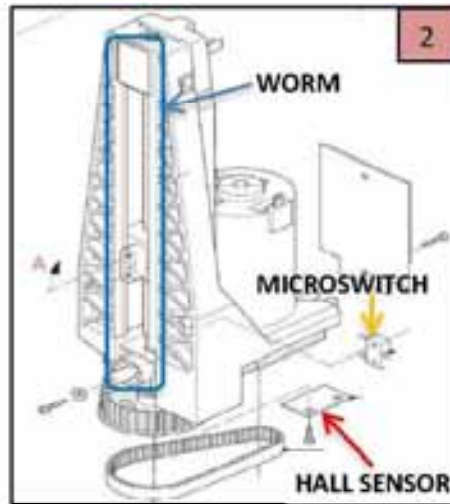

- It's driven by an electrical DC motor (direct current) 230/240V;
- This movement have to be very precise because is the responsible of the coffee pressing, detail that can change drastically the taste of coffee;
- The calculation of its movement is executed from a hall sensor which calculate the rotations of a worm;
- Motor is provided with an apposite electronic card to reduce the interferences

# Main components

## INFUSER



TORQUE: 2,3 – 2,5 NM

TORQUE: 1,2 – 1.5 NM



LEVER FOR POD  
RELEASING

CYLINDER /  
MAIN BODY

COFFEE OUTLET

COFFEE FILTER

O-RINGS

PISTON

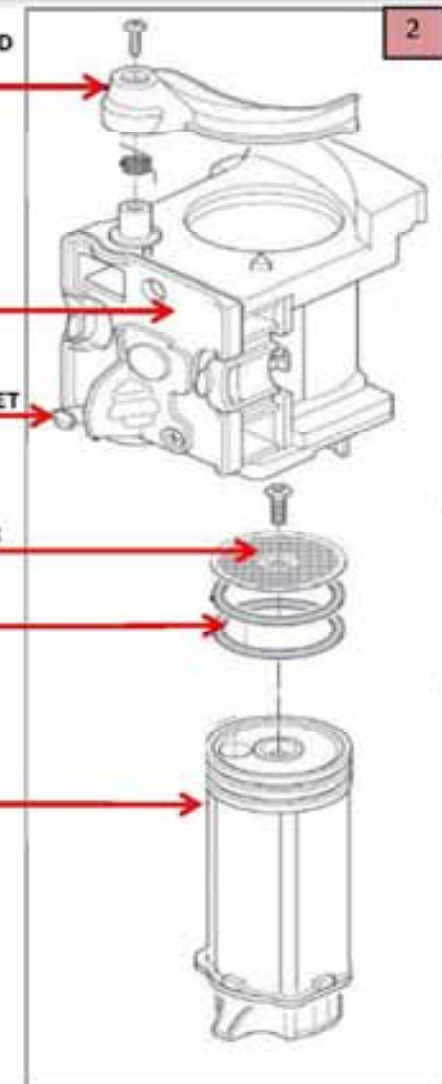

The infuser is positioned in the last part of the coffee circuit, it's connected to the transmission kit and its move along to it.

-Have the role to receive the coffee powder and to press it against the mechanical valve, as well as is responsible to let flow the water coming from the mechanical valve, through the coffee pod and eventually out from coffee outlet (in direction of coffee dispenser).

-Can be extracted and cleaned easily

-Have variable capacity (from 7 to 14 gr);

# Main components

## ***INFUSER MOVES AS FOLLOW DESCRIPT***

- 1. ZERO POSITION:**  
Infuser completely down, lower switch is pressed, pod releasing lever is pushed out (Pod into drip tray);
- 2. INFUSER EXTRACTION:**  
This position is reached when machine switch off, is possible to remove the infuser;
- 3. READY FOR COFFEE:**  
Infuser is positioned under the grinder output, ready to receive coffee powder;
- 4. TOP POSITION:**  
Infuser is pressed against the mechanical valve, ready for coffee pouring.

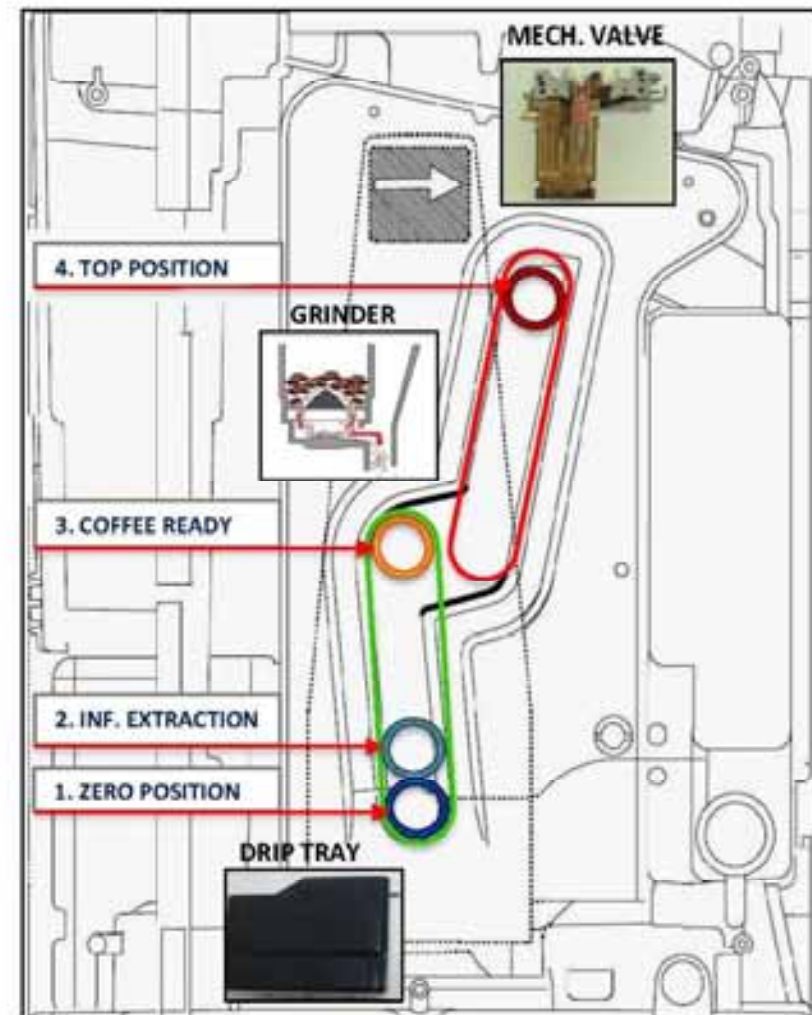

# Main components

## INFUSER

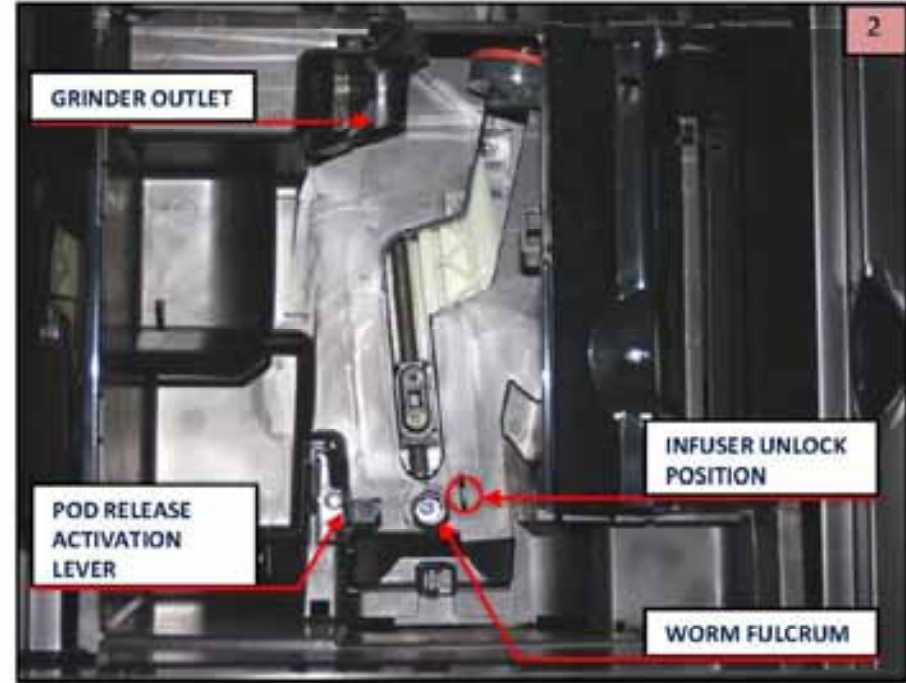
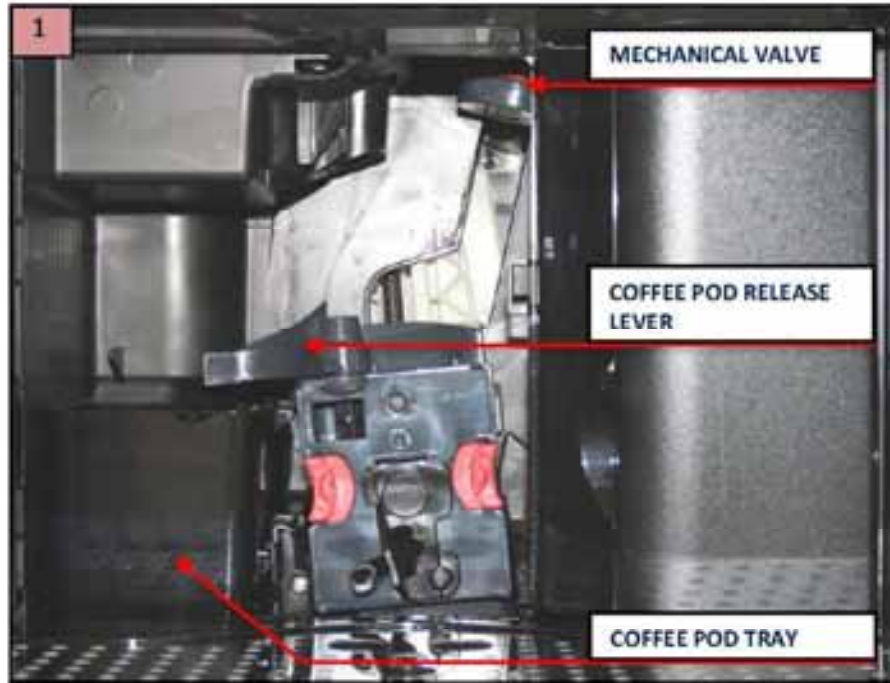

- In picture 1 is shown infuser in its lower position "0", lever it's out for release the pod into the pod tray;
- "0" position doesn't correspond to extraction position, which is upper and with pod levers back;
- In picture 2 you can see highlighted the worm fulcrum, levers for infuser unlock and pod release activation lever.

# Main components

## GRINDER

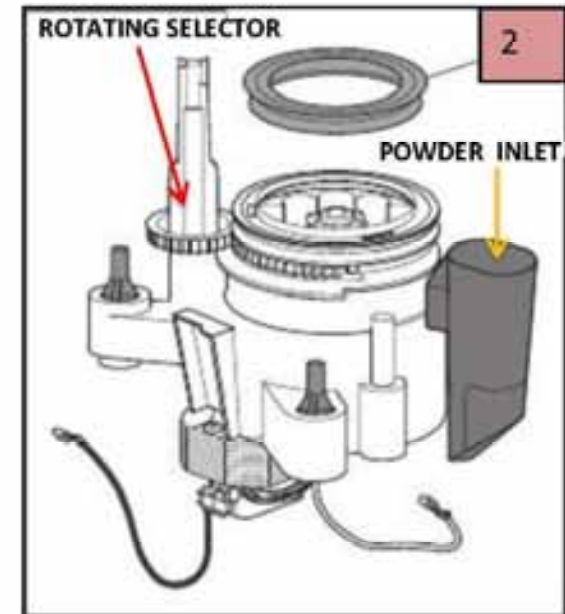
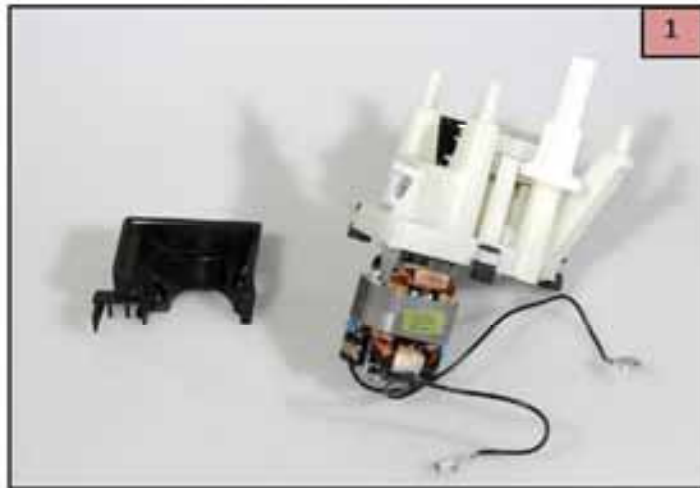

- It grind coffee beans to obtain powder(pic.3)
- It is driven by an electric motor AC (alternate current) 230/240V;
- Is possible to set the dimension of the ground obtained by a rotating selector (Pic.2) up to 13 different settings,

# Main components

## GRINDER

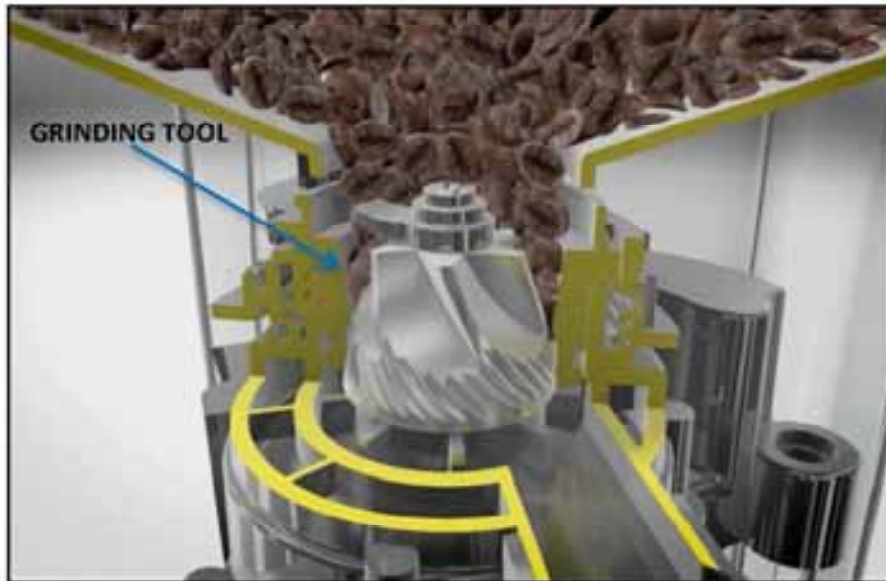

**STANDARD GRINDING TIME (FACTORY SETTING, SELECTION: NORMAL): 5,6 SEC**

*NOTE: machine's grinding time is adaptive: basing on the infuser's position, machine deduce the quantity of coffee present and change the grinding time in order to obtain the quantity of coffee requested.*

- Settings can be modified by set the selector (see procedure: "grinder set up").
- Grinder is provided with a clutch in order to protect the part from foreign particles;
- After being grounded, coffee is released into the infuser passing through a tubeless connection, this outlet is shared with the coffee powder's inlet (Pic.2).

---

# Parameters and Their Measurement

# Parameters and their measurement

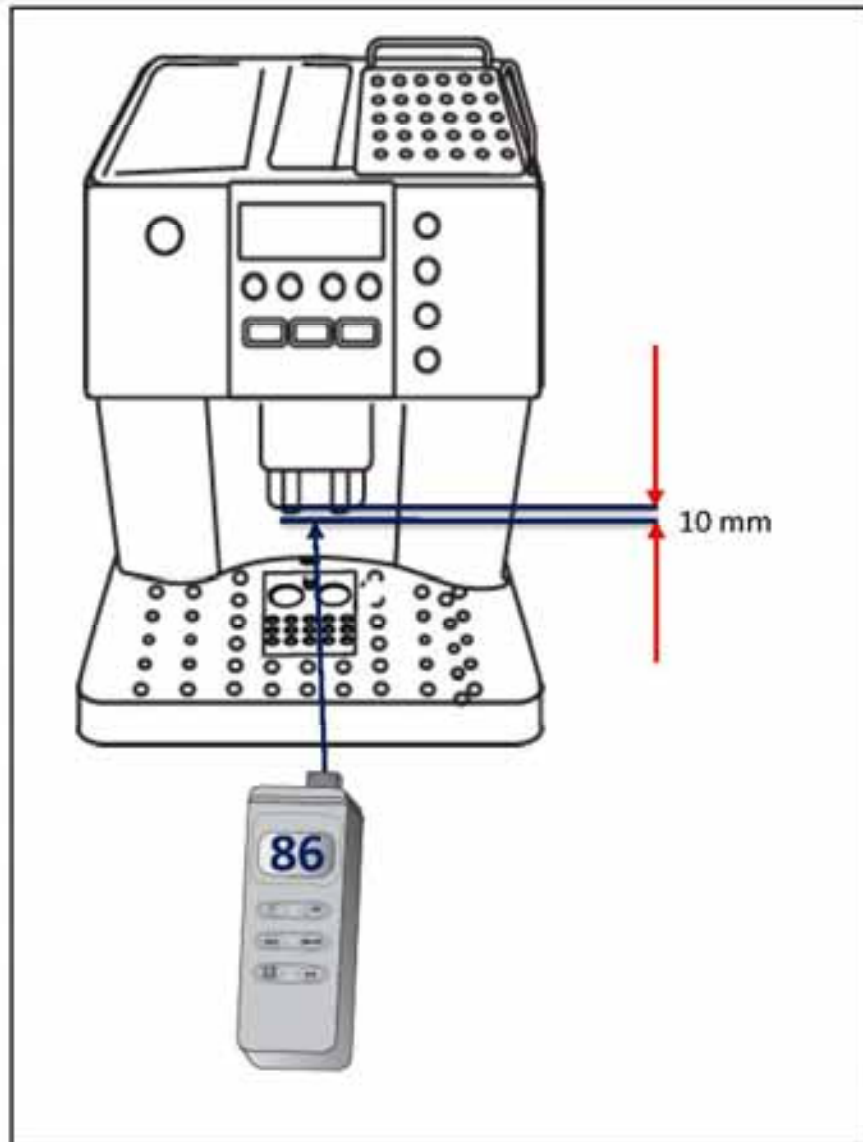

## **WHEN TEMPERATURE TEST IS NEEDED:**

Complains about coffee temperature are quite frequent, mainly are due to incorrect machine adjustments or to a not correct expectation from customer side.

A measurement of the temperature of the coffee must be performed each time you encounter these complaints.

## **HOW TO PERFORM THE TEST:**

1. Turn the machine on;
2. Running a rinsing cycle;
3. Set the temperature to (max);
4. Press and select the option "LONG COFFEE";
5. Wait for there to be at least 20 ml of coffee in the container;
6. Measure the flow temperature 2-10 mm away from the spout (as indicated in the figure).

The indicative temperature must be  $86^{\circ}\text{C} \pm 3^{\circ}\text{C}$

# Parameters and their measurement

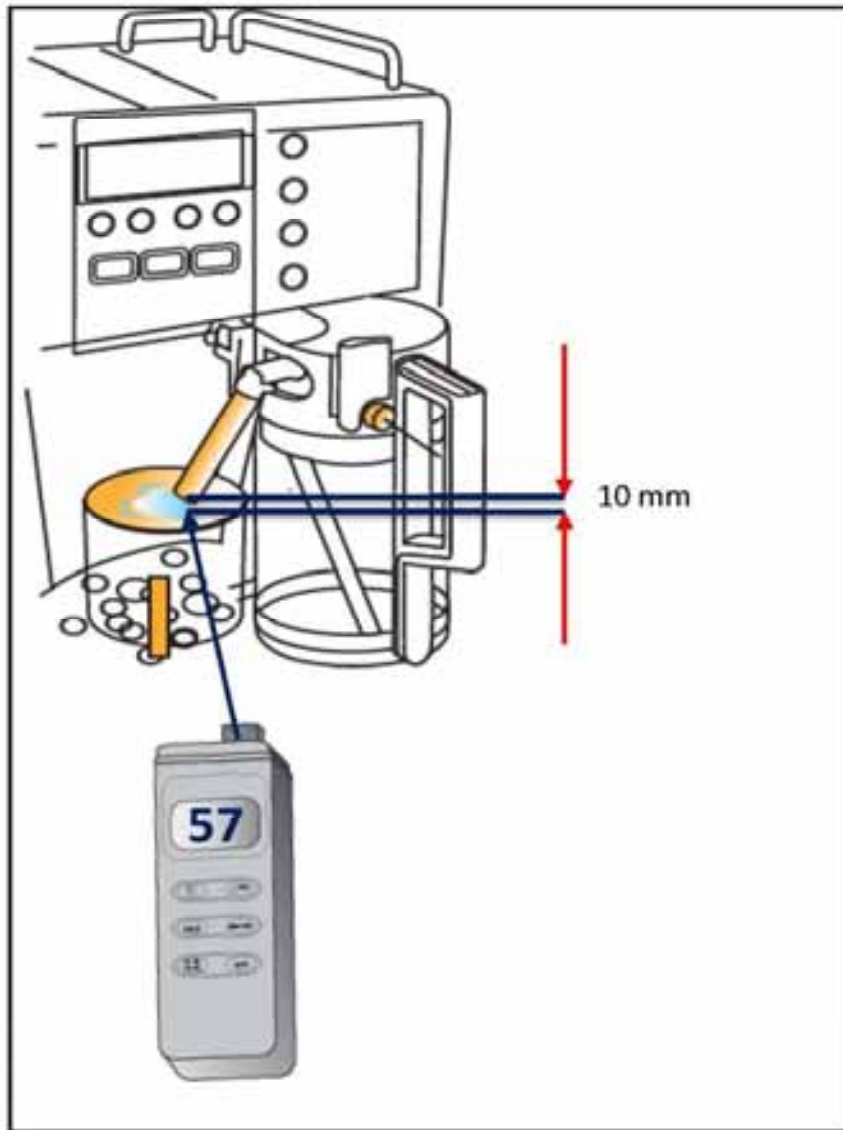

## **WHEN TEMPERATURE TEST IS NEEDED:**

Whenever get complains on milk's temperature or quality

## **HOW TO PERFORM THE TEST:**

- 1 Turn the machine on.
2. Fill the milk container with 200 ml of semi-skimmed milk at a temperature of  $5^{\circ}\text{C} \pm 2^{\circ}\text{C}$ . Insert the lid on the container and install it on the machine. Turn the froth knob to (MAX). Place a 250 ml Pirex graduated receptacle in correspondence of the milk spout.
- 3 .Use a K-type digital thermometer with thermocouple sensor and place it under the milk spout.
4. Press MILK and deliver 100 ml of milk.
5. Measure the milk temperature while it is delivered.

## **VERIFY AS FOLLOWING:**

Appearance of the froth: no splashes

Milk temperature:  $57^{\circ}\text{C} - 67^{\circ}\text{C}$ .

Froth amount: the final result in the Pirex cont must be 1/2 milk and 1/2 froth.

---

# Wiring Diagrams

# Wiring diagrams/PCB

---

## *MAIN PCB (POWER CONTROL BOARD)*

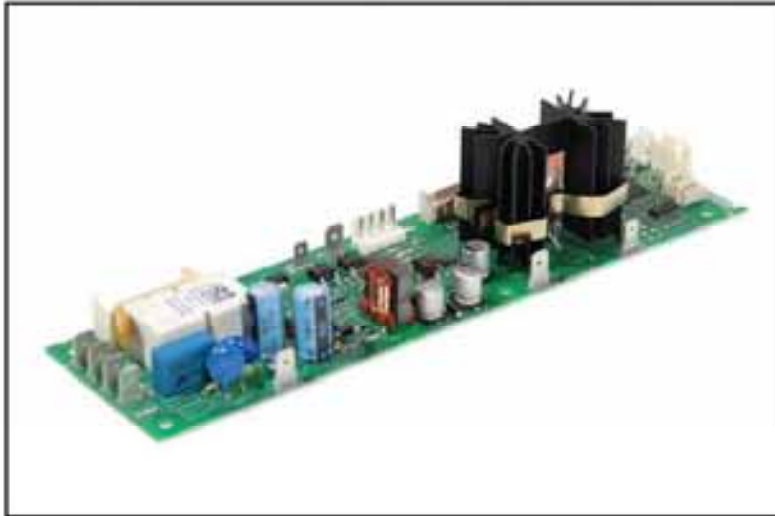

- Main PCB is the component that define all the logics of the machine's operations;
- It's very important to use the same code of PCB if used for a replacement, a wrong PCB code would compromise drastically the functions of the appliance;
- in following pages you can find documentation related to wiring connections:

# Wiring diagrams/PCB

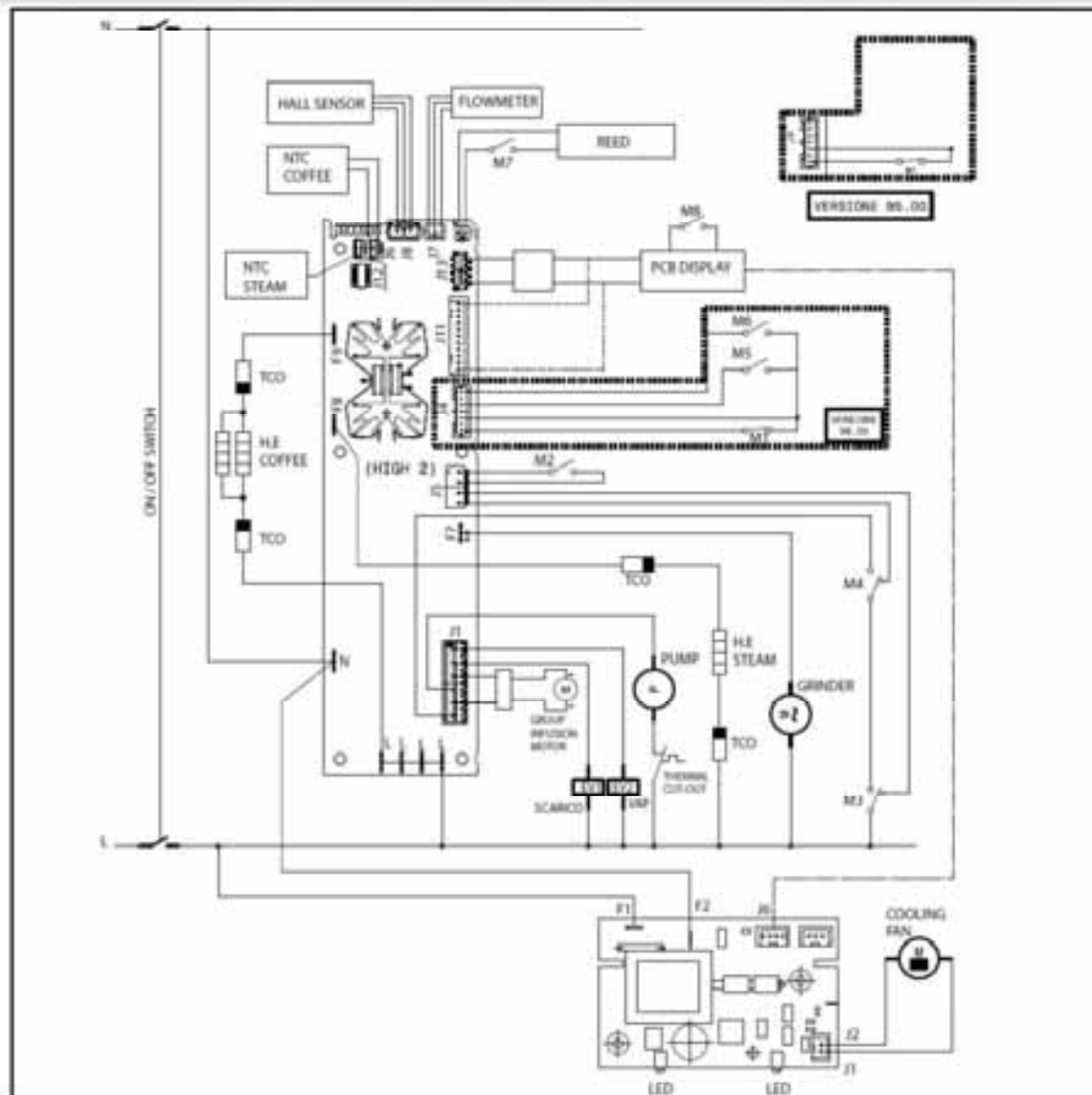

## THEORETICAL OUTLINE

M1 Microswitch upper

M2 Microswitch lower

M3 Microswitch drawer

M4 Microswitch door

M5 Microswitch milk container

M6 Microswitch steam spout

M7 Microswitch water tank

EV1 Electrovalve 3 ways

EV2 Electrovalve 2 ways

EV3 Electrovalve 2 ways











TCO Termofusibile Thermal cut off

HE Heating element

---

# Diagnostic and Troubleshooting

# Diagnostic and troubleshooting

LOAD TEST MODE				
	Test	Procedure	Pressing each icon below, we can manually check the devices	
			icon	devices
	LOAD TEST MODE	<p>with the machine in stand-by (plugged in with the main switch on I, but machine OFF), open the Service door. Keep the icons, MENU *, , , pressed till on the display is shown the message "SELECT TEST" (min. 6 seconds). Close the door and then press on the icon , *. The display will show the message: "LOAD TEST MODE"</p> <p>To exit to the test, turn OFF the power.</p>	On / Stand by	Vaporizer On
			Grinder On	
			Pump On	
MENU			Motor Up	
			Motor Down	
			Heating On	
			EV1 On + Fan	
			EV1+EV2 + Light	
			EV2	



# Diagnostic and troubleshooting

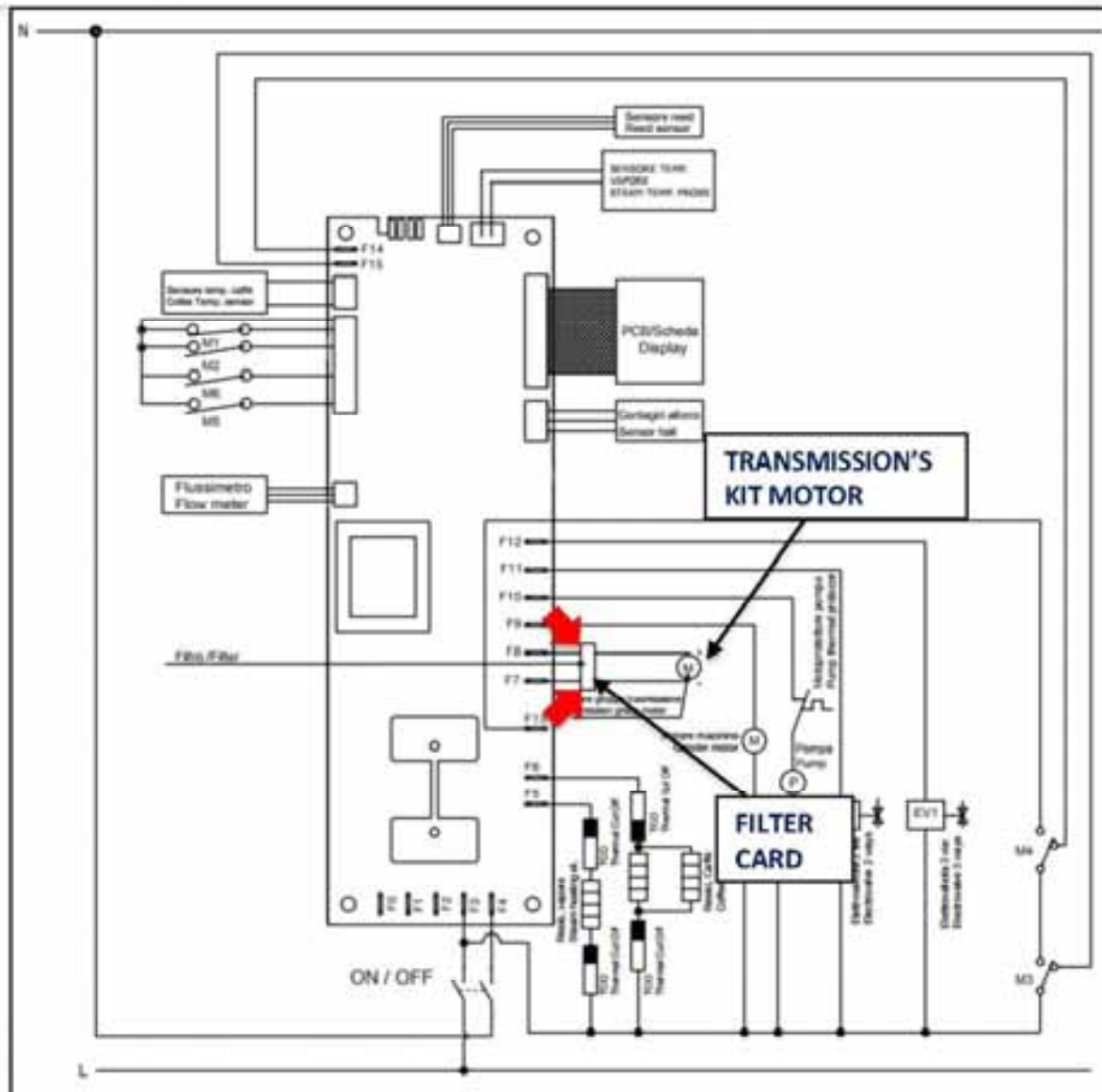

## **VERIFICATIONS WITH TESTER (TRANSMISSION):**

To verify transmission's kit value, is suggested to check it on the filter card connectors (highlighted with red arrow)

Indicative Value: 200V (DC)

# Diagnostic and troubleshooting

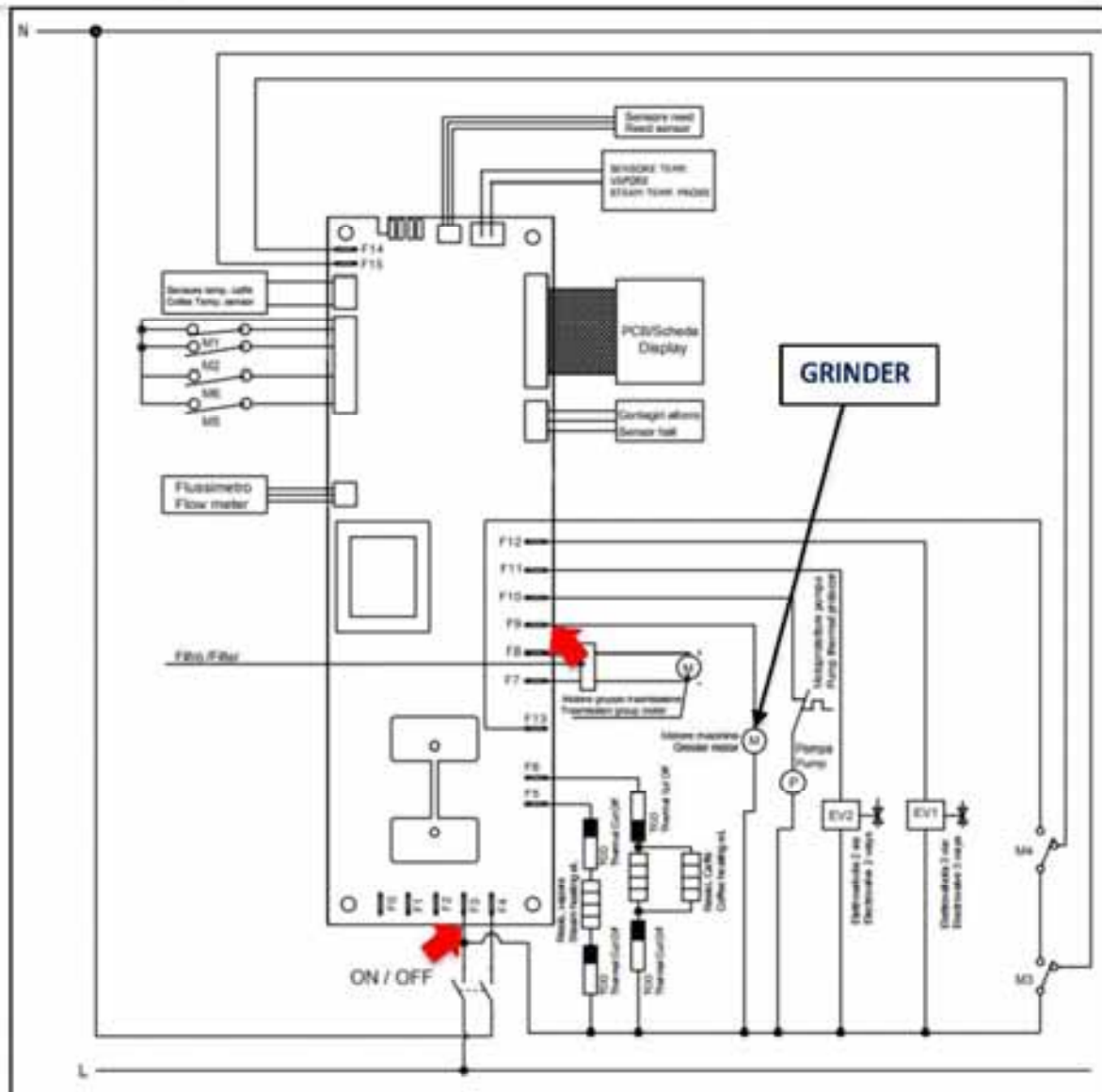

## **VERIFICATIONS WITH TESTER (GRINDER):**

To verify grinder value, is suggested to check it on the related PCB connectors (highlighted with red arrow)

Indicative Value: 230 V (AC)

# Diagnostic and troubleshooting

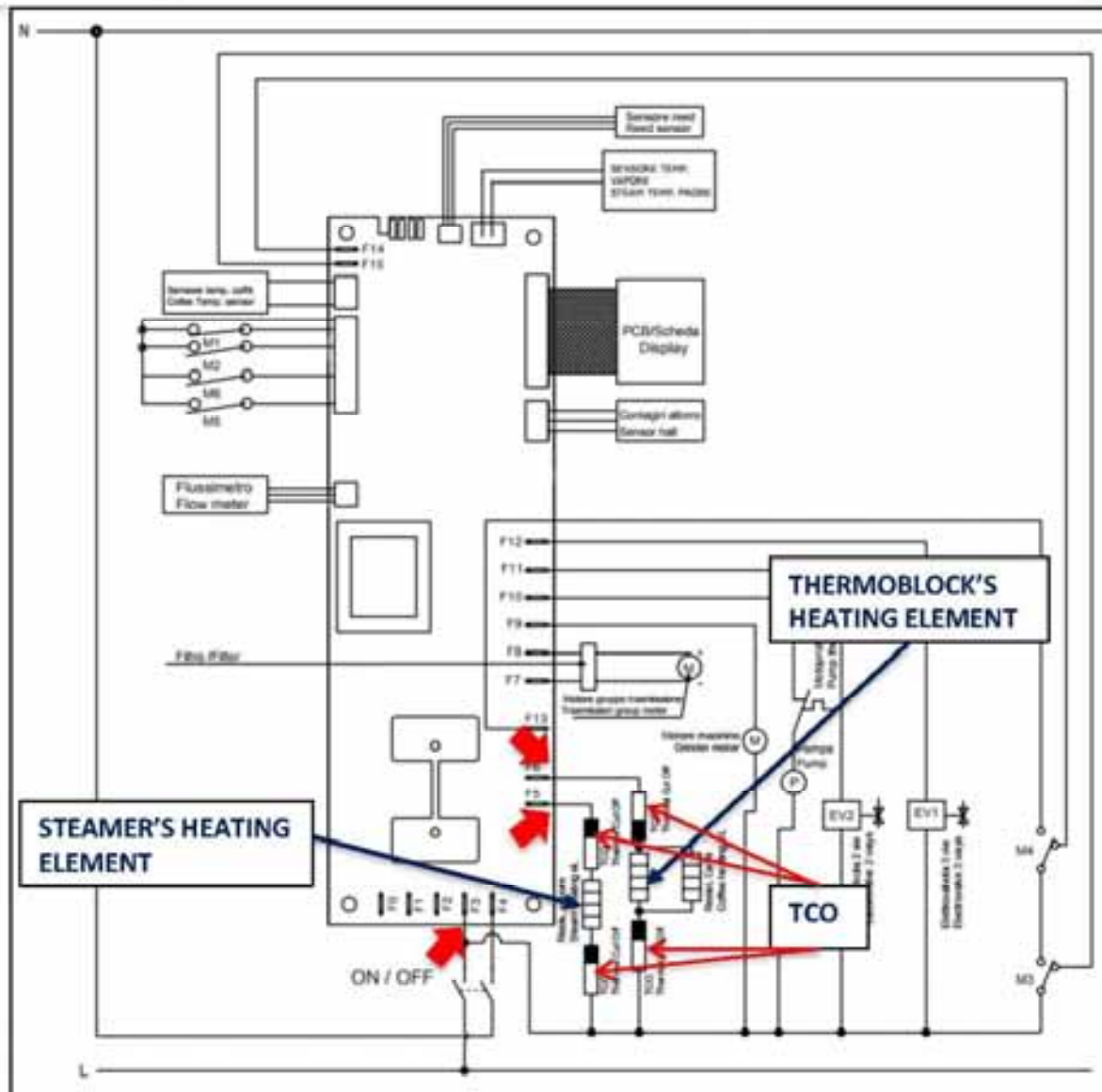

## VERIFICATIONS WITH TESTER (HEATERS):

To verify thermoblock and steamer heater value, is suggested to check it on the related PCB connections (highlighted with red arrow)

### THERMOBLOCK:

Indicative values: 230 V (AC)  
37,7  $\Omega$

### STEAMER:

Indicative values: 230 V (AC)  
52,9  $\Omega$

# Diagnostic and troubleshooting

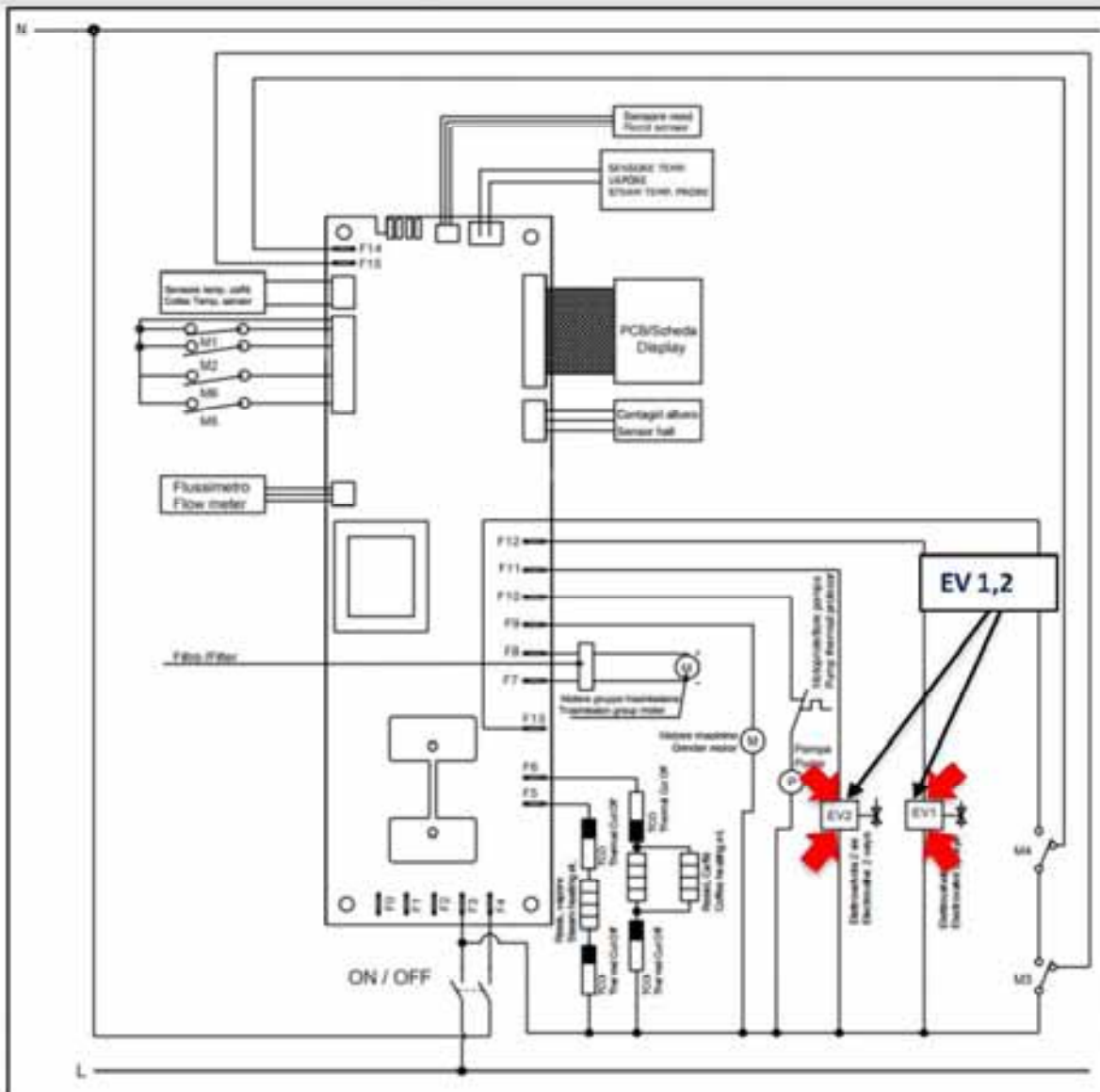

## VERIFICATIONS WITH TESTER (EL. VALVES):

To verify grinder value, is suggested to check it on the related Electrovalves connectors (highlighted with red arrow)

Indicative Value: 220V (AC)

# Diagnostic and troubleshooting

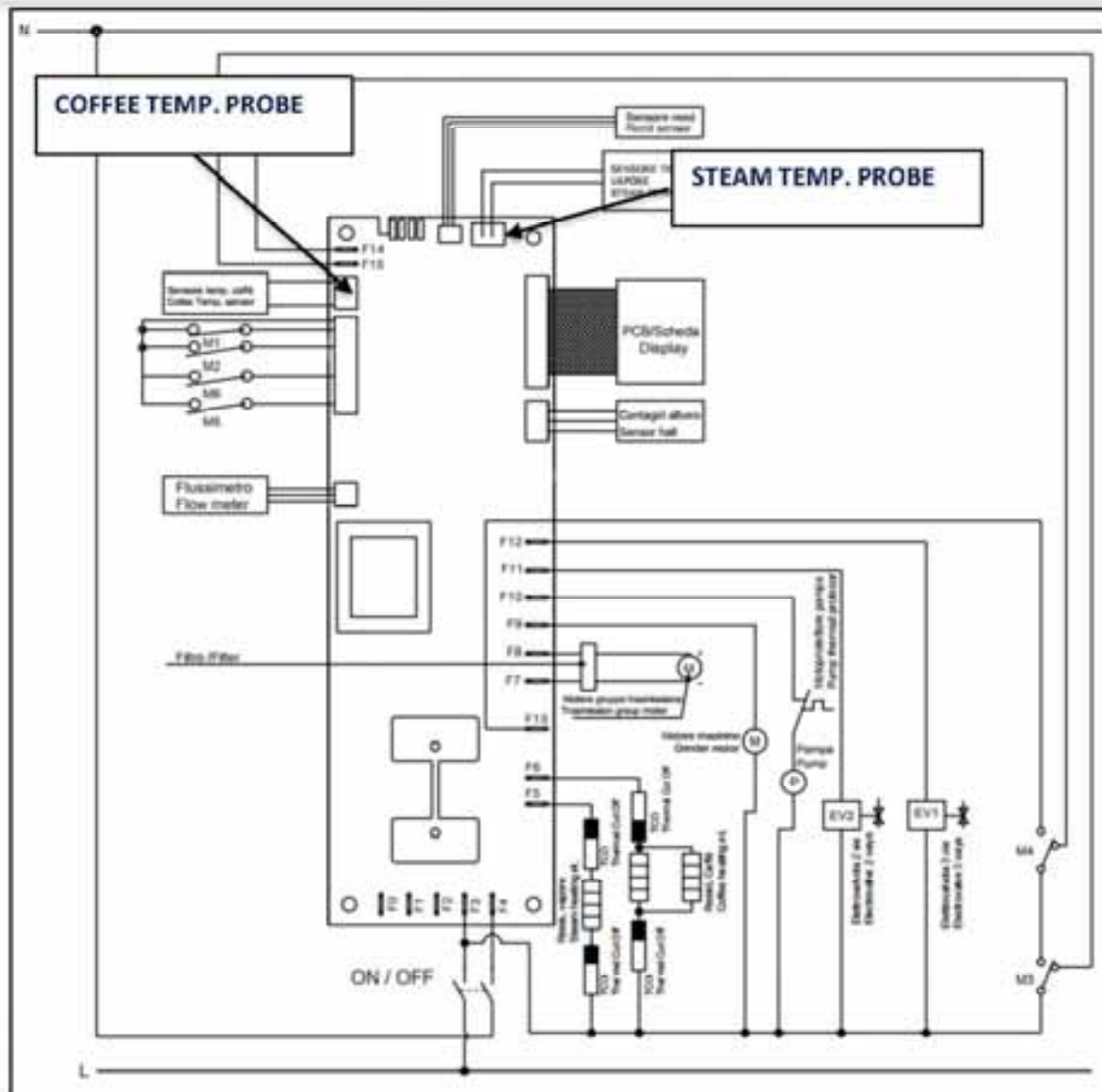

## VERIFICATIONS WITH TESTER (PROBES):

To verify grinder value, is suggested to check it on the related PCB connectors (highlighted with red arrow)

## Indicative Values:

Check following page indicating correct value for related environment's temperature

# Diagnostic and troubleshooting

## TEMPERATURE PROBES OHM VALUES

Temp. [°C]	R Nom [Ω]	R Min [Ω]	R Max [Ω]
-10	595038	555067	635009
-5	455053	425872	484234
0	350858	329386	372330
5	271575	255719	287430
10	211861	200065	223656
15	166517	157680	175354
20	131815	125151	138479
25	105059	100002	110116
30	84281	80421	88141
35	68035	65073	70997
40	55249	52964	57534
45	45124	43353	46895
50	37057	35678	38436
55	30592	29514	31670
60	25383	24537	26229
65	21163	20497	21830
70	17728	17201	18254
75	14916	14499	15333
80	12605	12274	12936
85	10697	10433	10960
90	9113	8903	9323
95	7794	7627	7962
<b>100</b>	<b>6691</b>	<b>6557</b>	<b>6825</b>

# Diagnostic and troubleshooting

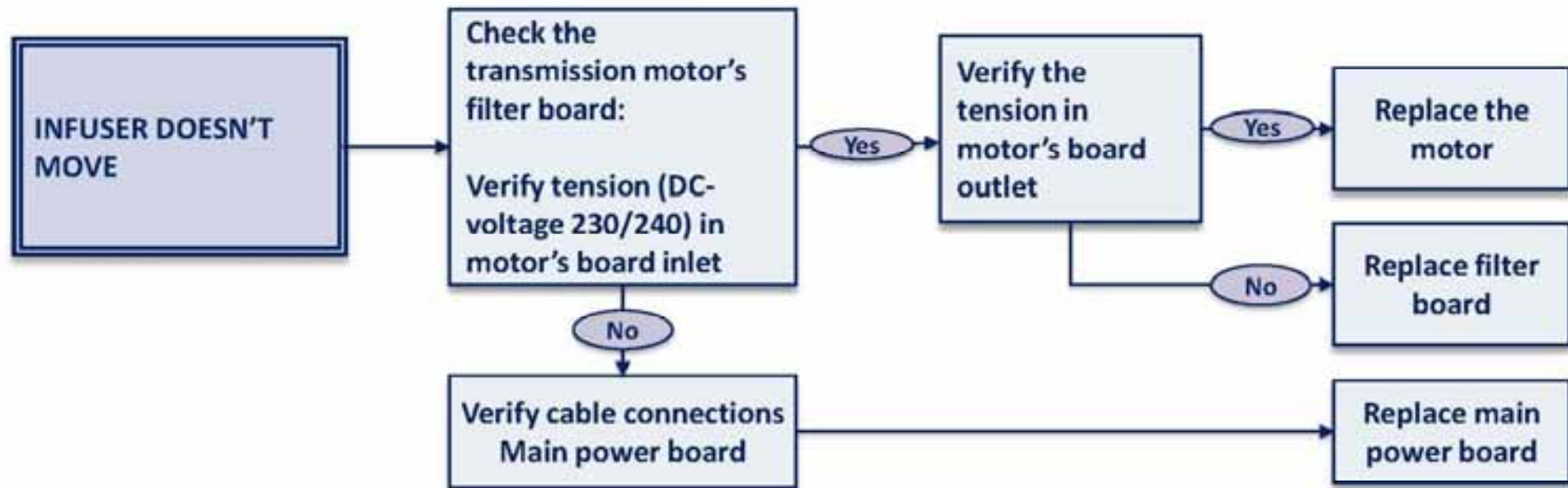

# Diagnostic and troubleshooting

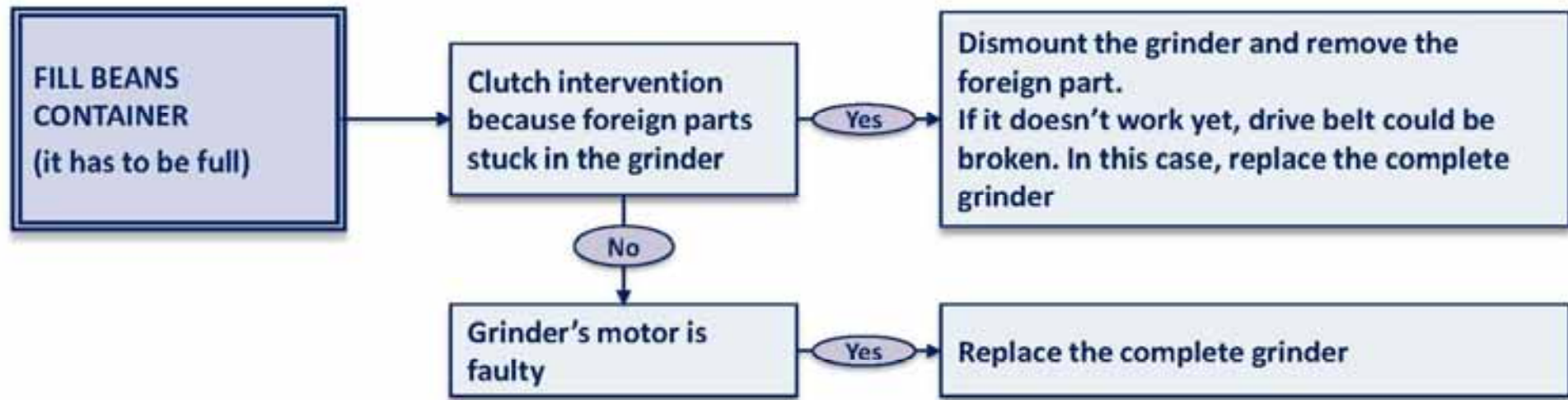

# Diagnostic and troubleshooting

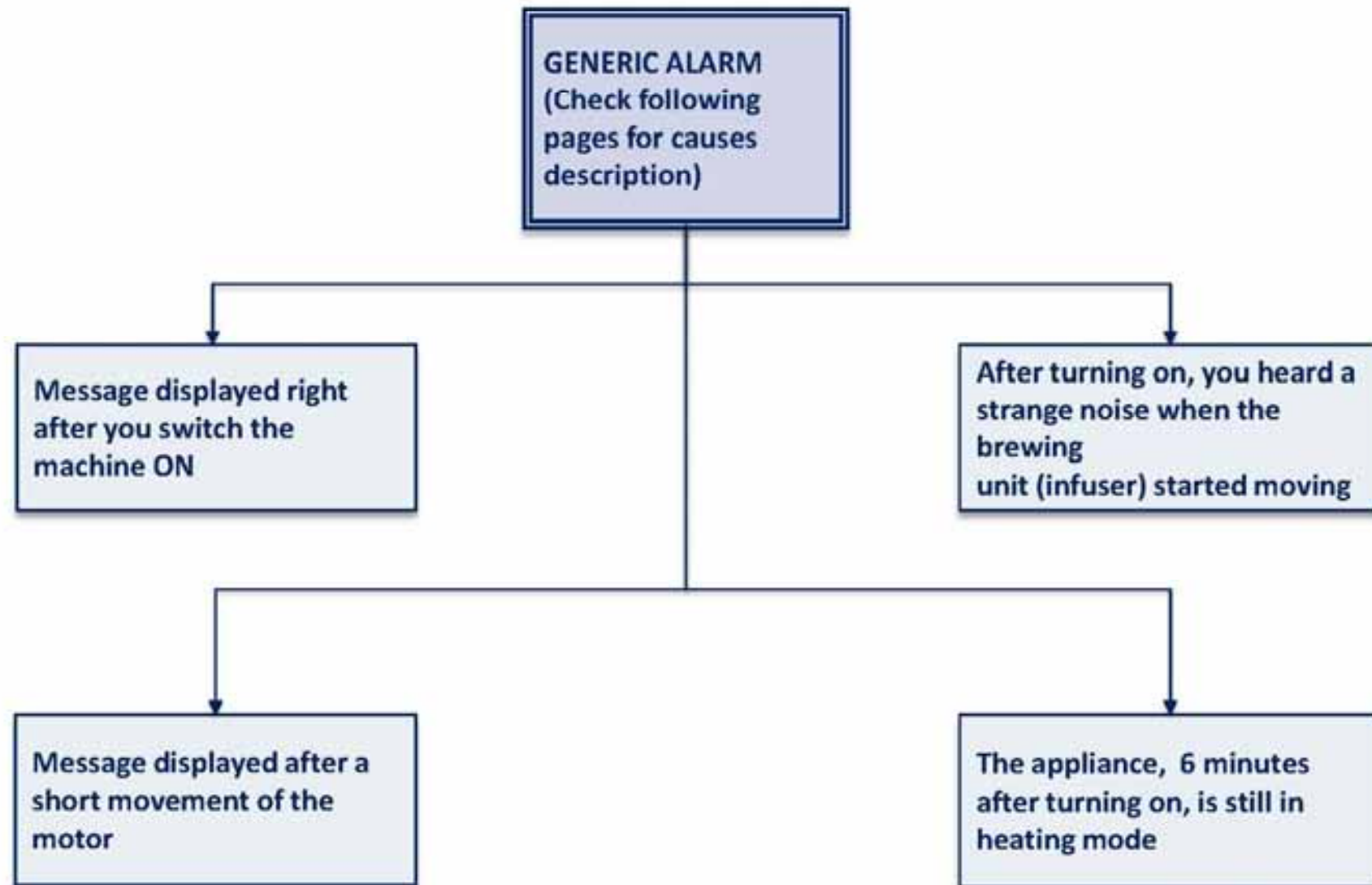

# Diagnostic and troubleshooting

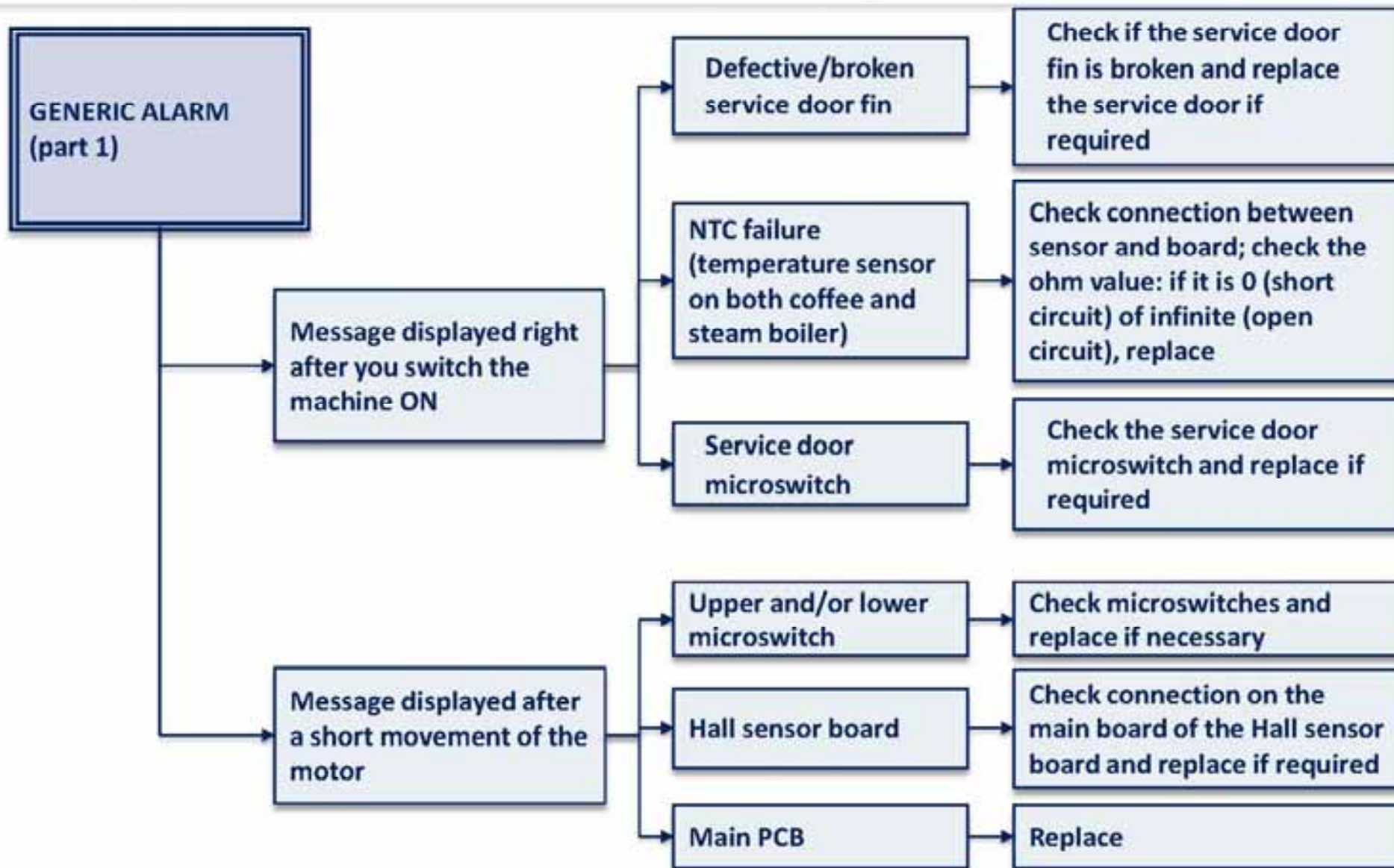

# Diagnostic and troubleshooting

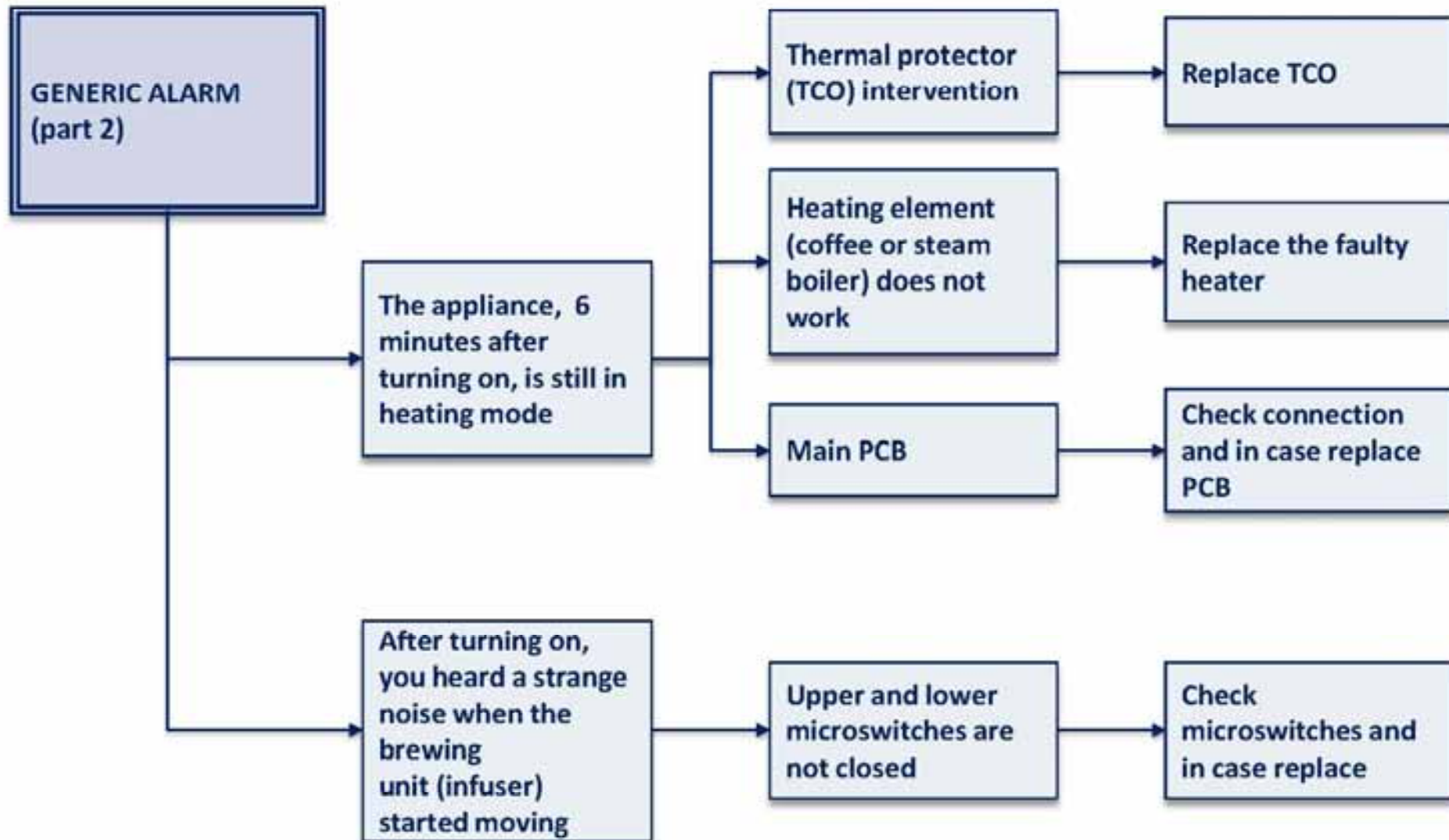

# Diagnostic and troubleshooting

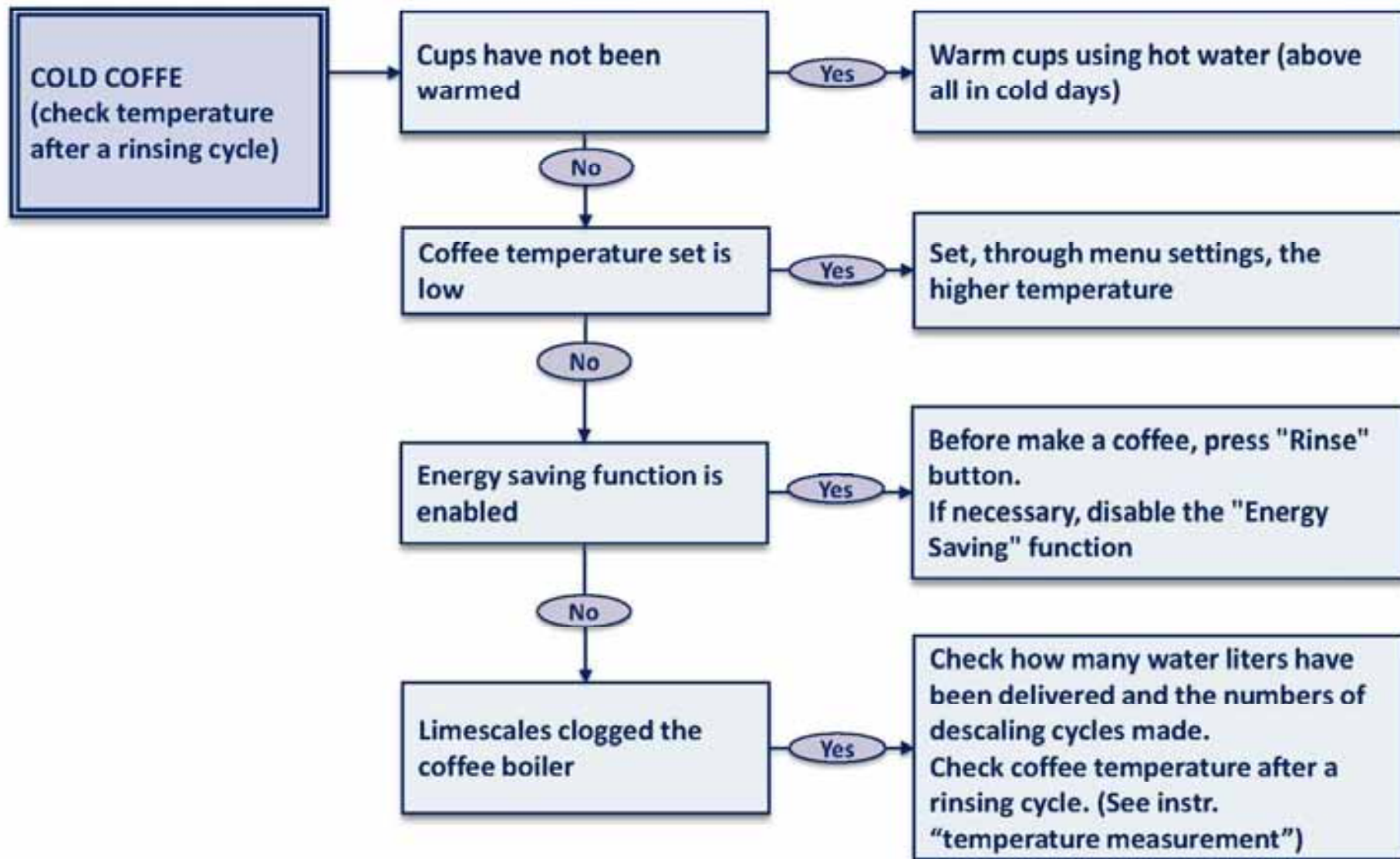

# Diagnostic and troubleshooting

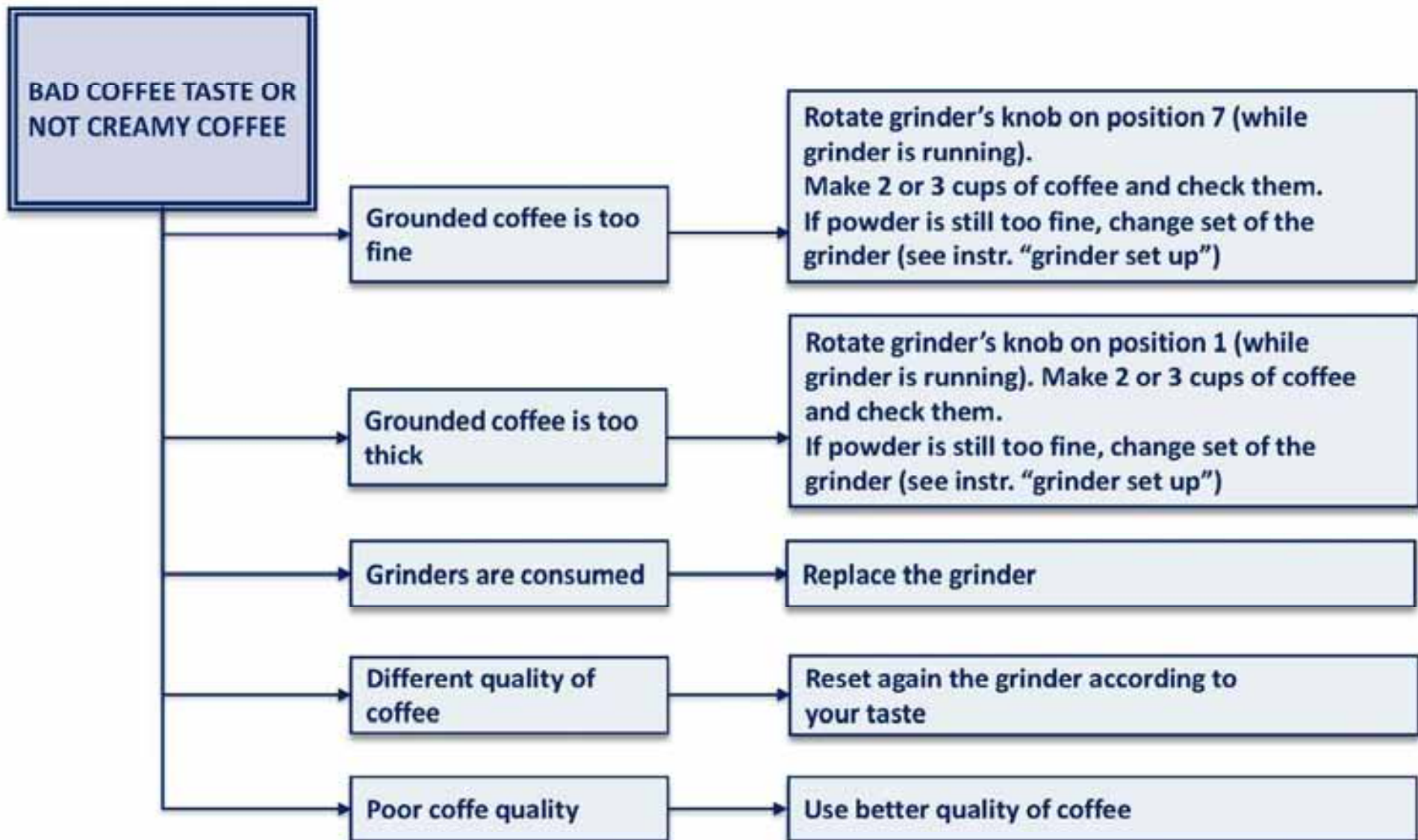

# Diagnostic and troubleshooting

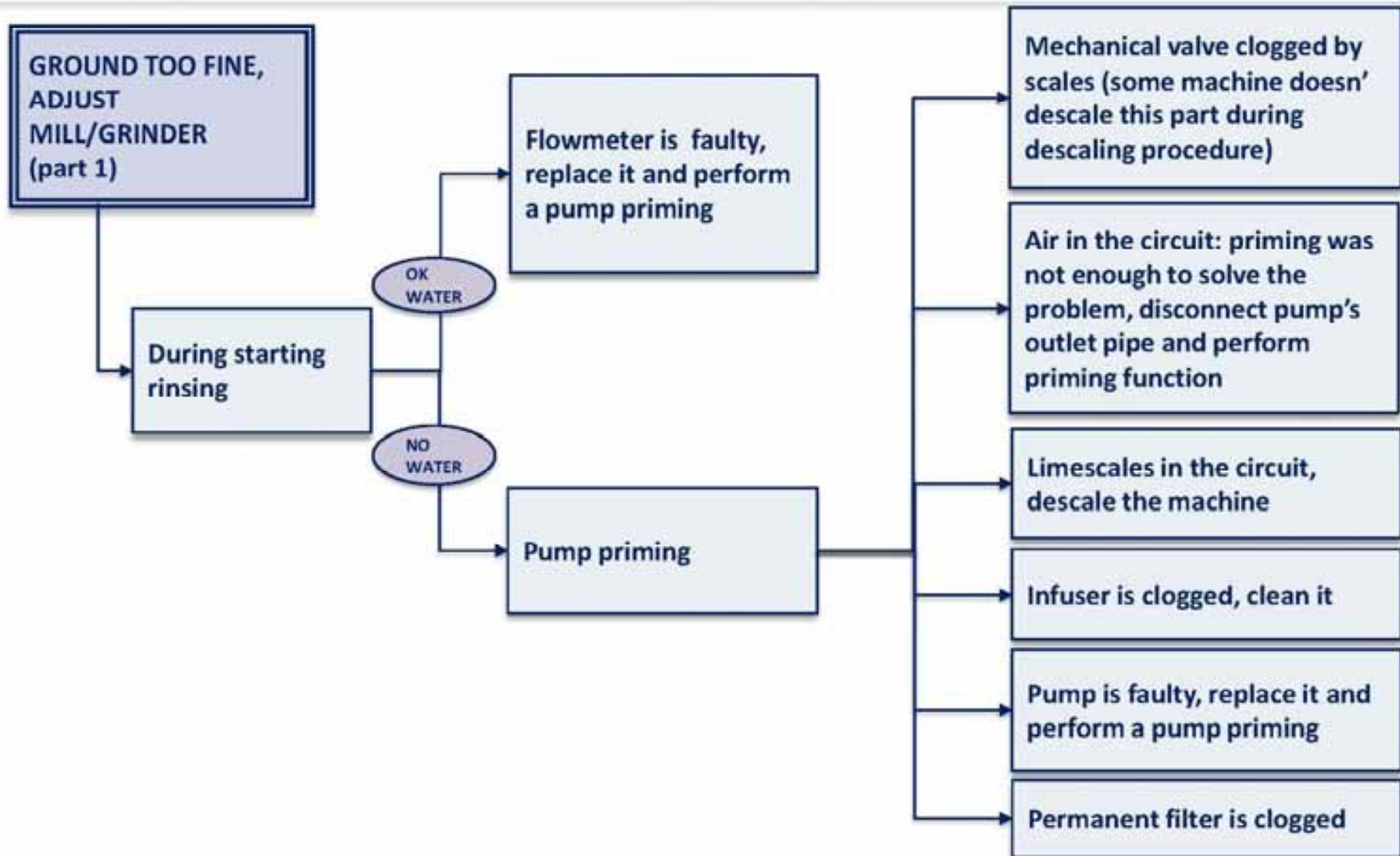

# Troubleshooting

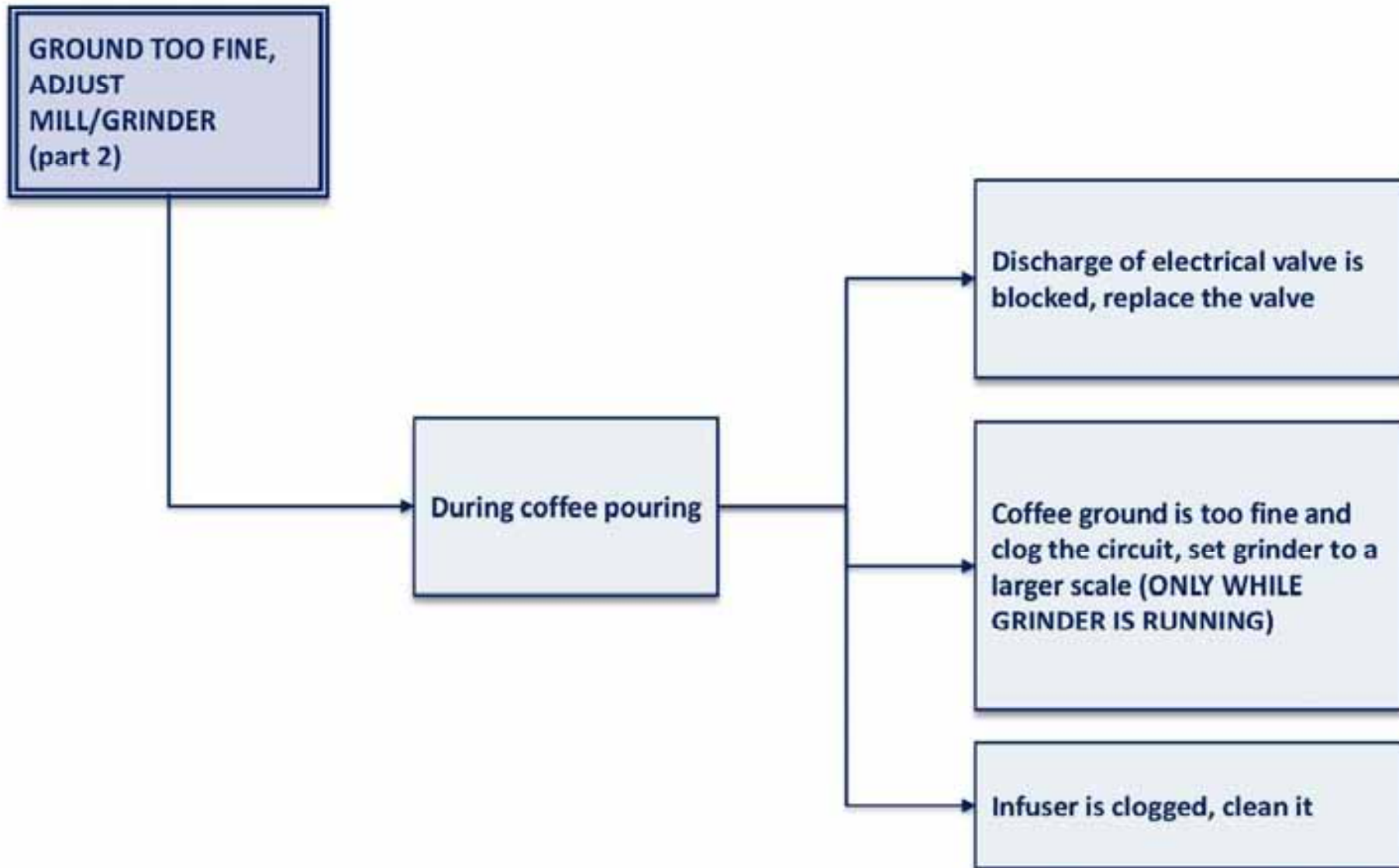

# Diagnostic and troubleshooting

---

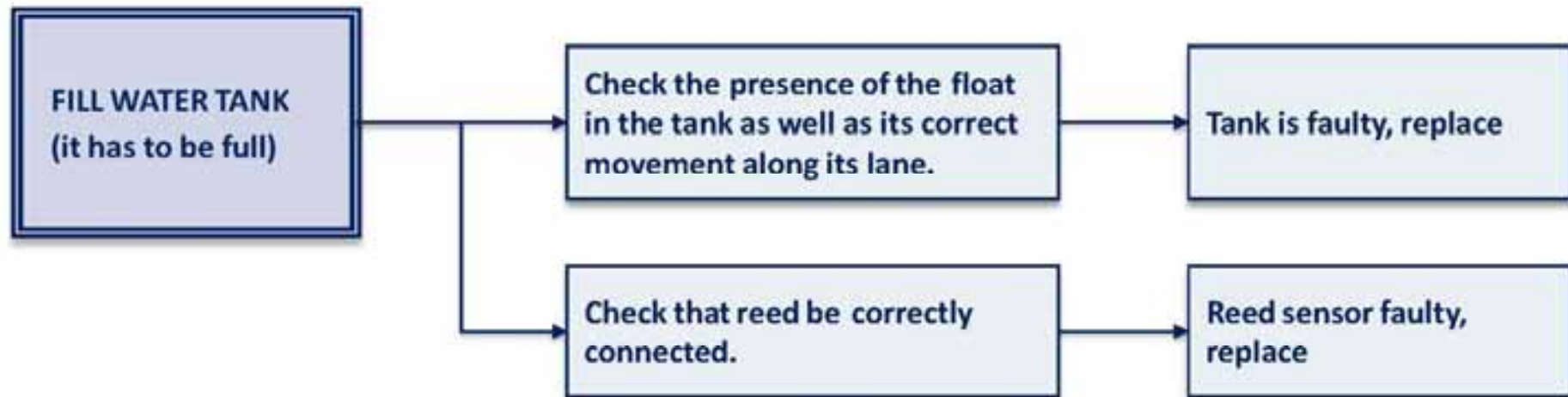

# Diagnostic and troubleshooting

---

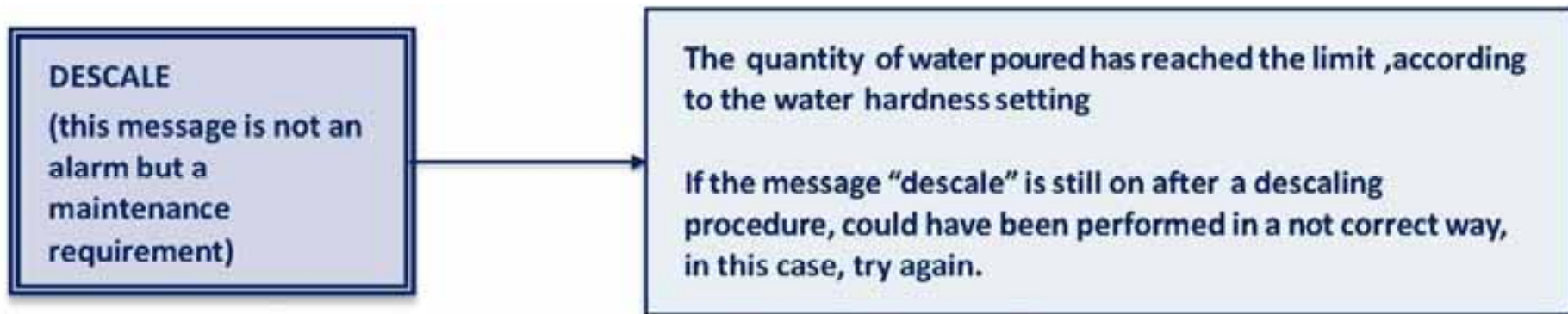

---

# Cleaning and Maintenance

# Cleaning and maintenance

## DESCALING

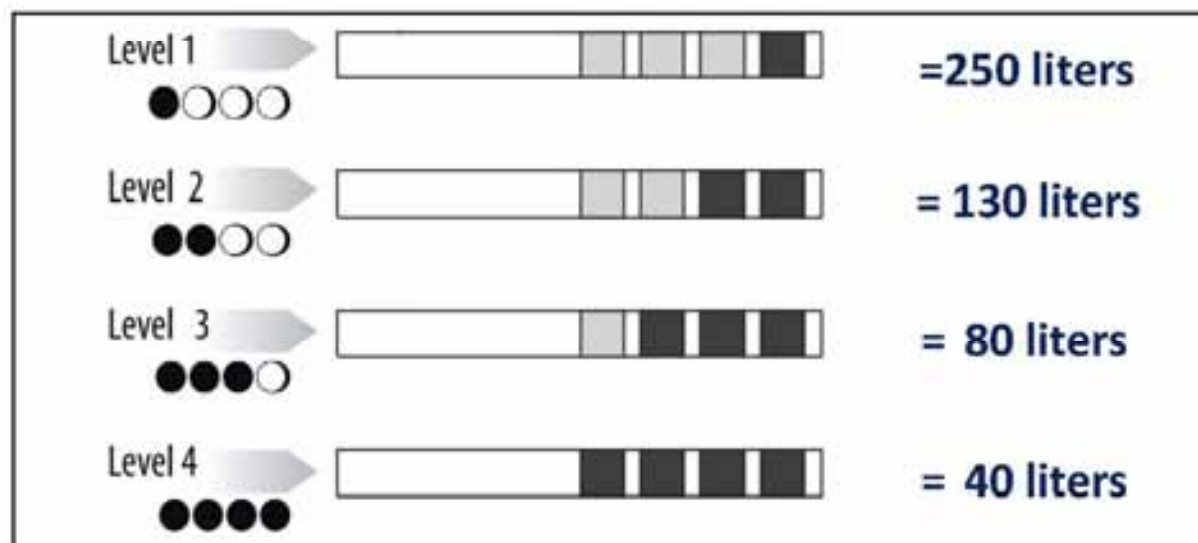

-DESCALING is a maintenance procedure performed in order to remove deposits of limestone inside the machine's circuit. Lacking of this operation could interfere with the correct functioning of the appliance.

-The DESCALE message is displayed after a period of time established according to water hardness. The machine is set by default for a hardness value of 4. The machine can also be programmed according to the actual hardness of the mains water in the various regions, varying the frequency with which the message is displayed.

# Cleaning and maintenance

---

## **INFUSER'S CLEANING**

-The infuser's cleaning is a standard maintenance procedure, an exceptional maintenance procedure could be necessary if the components inside stuck to each other.



-A limited mobility of infuser's piston could interfere with the pod discharging, in this case, the lever's movement could remove only a part of the pod, keeping the rest inside the infuser.

-Instructions about how to perform this operation are in technical bulletin (IT0108).

- NOTES:**
- Infuser have to be already removed from the machine for check manually its movement*
  - To verify infuser's mobility press manually the 2 "levers for piston handling" to each other;*
  - *To be able to remove the infuser, machine must be switched off.*

# Cleaning and maintenance

## **GRINDER SETTING:**

Below you can find the instructions to change the default grinder setting



1. Unscrew the Knob and pull it out. Unscrew the 2 screws and Remove grid of protection



2. Rotate the post Ring in the direction Hours till end race. Take out the grinder mobile



3. Check the correct placement Of the gasket



4. Remove the locking ring

# Cleaning and maintenance

---

## GRINDER SETTING:



5. Rotate the nut post counterclockwise until it stops and remove it.



6. Turn the dial clockwise to grind + END.  
Turn the nut in ANTI-CLOCKWISE to grind + thicker. Rotate 1 or 2 shots at a time



7. Insert the ring post with the notch marking the notch mark.



8. Insert the locking ring in the correct position.

# Cleaning and maintenance

---

## **GRINDER SETTING:**



9. Turn the shaft clockwise until the end of the stroke and insert the grinder. Then turn it counterclockwise until the end of travel.

# SERVICE TRAINING COURSE

## CAPLE CM 465

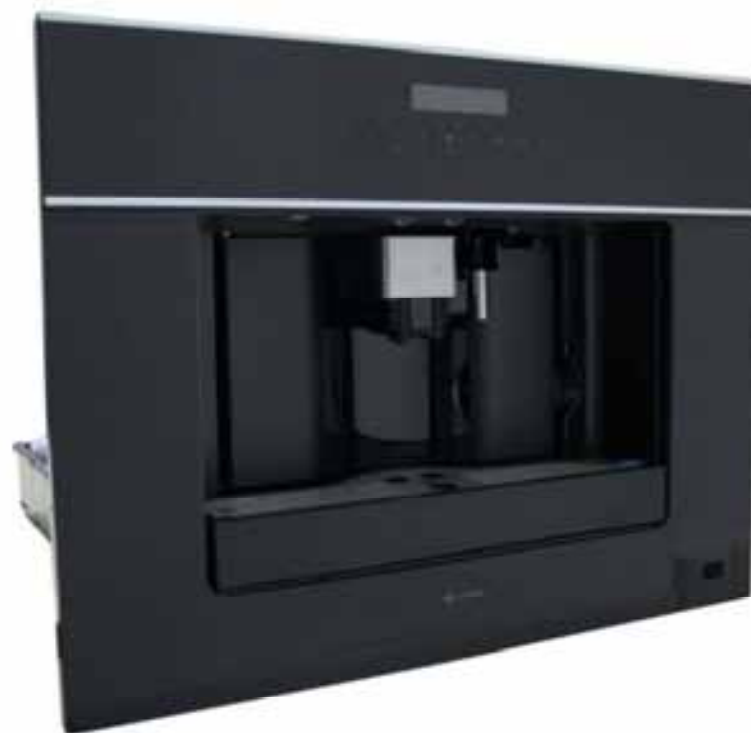

THANK YOU FOR YOUR ATTENTION