



Instruction manual for Telescopic hood

Model code: TSCH



Warning

Your cooker hood is for domestic use only, not suitable commercial use.

Keep children from using the cooker hood.

Any installation work must be carried out by a qualified electrician or competent person.

The cooker hood and its filter mesh should be cleaned regularly in order to keep in good working order.

Before cleaning, always ensure that you have switched your cooker hood off.

Clean the cooker hood according to the instruction manual and keep the cooker hood from the danger of burning.

Do not use fire for drying your cooker hood.

If there is any fault with your cooker hood, please call the service department appointed by Caple.

Please keep the room ventilated when your cooker hood and gas hob are working.

Do not exhaust the cooker hood through the same heated flue which is used for the gas hob or other kitchen appliances.

Thank you for purchasing this Caple cooker hood. Please read the instruction manual carefully before you use the hood, and keep it in a safe place.

· The installation work must be carried out by a qualified electrician or competent person. Before you use the cooker hood, make sure that the voltage (V) and the frequency (Hz) indicated on the cooker hood are exactly the same as the voltage (V) and the frequency (Hz) in your home.

· The manufacturer and the agent will not bear any responsibility for the damage caused by inappropriate installation and usage.

Function and Feature

1. The cooker hood is made of high quality materials perfect your kitchen.
2. It is equipped with a high power low noise electric motor and centrifugal leaf, it produces strong suction, low noise. It includes a non stick grease filter which is easy to clean.
3. The grease filter is easy to remove and clean, and only wipe the motor and other interior parts lightly.

Installation

There are two ways of installation of cooker hood on the wall and under a wall unit.

Method A: Mounting on the wall,

- 1) The cooker hoods should be placed at a distance of 65-75cm from the cooking surface for best effect.
- 2) To install onto the wall drill 4 holes of $\text{Ø}8\text{mm}$ on a suitable place according with the centre distance of hole in the back of the cooker hood.
- 3) Insert the nut into the holes.
- 4) Insert the screws into the nuts and tighten.
- 5) Put up the cooker hood onto the fixed screws.

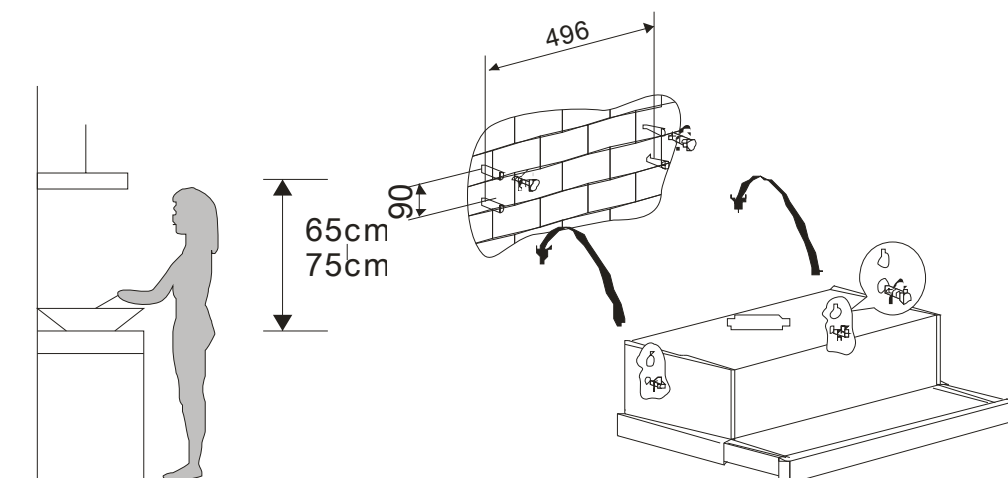

Method B Mounting under a wall unit

- 1) Drill 6 holes of 4mm diameter at the bottom of the hanging cupboard
- 2) Put the one way valve on the cooker hood, then install the cooker hood on the bottom of the cupboard, tighten the hood with the enclosed 6 screws.
- 3) Install the adjusted board on the bottom of the hood in order to keep out the gap between hood back and cupboard.

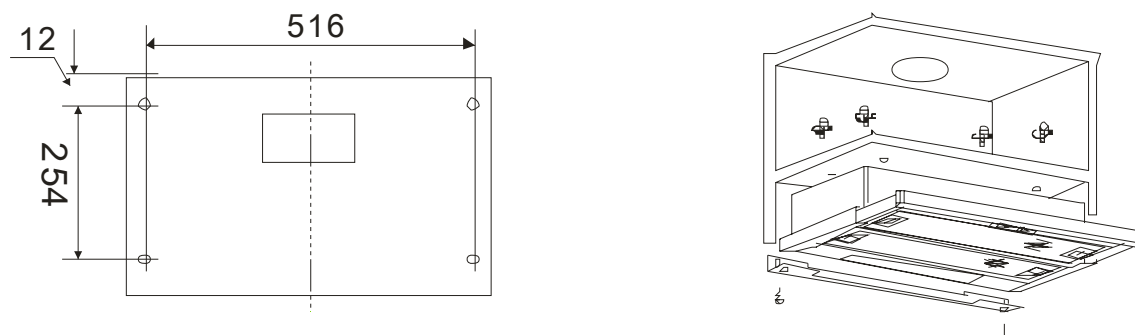

How to use the control panel:

- Press the button "Low", the inner indicator light of switch illuminates, the motor is now running at low speed. Press the button again, the motor stop.
- Press the button "Mid", the inner indicator light of switch illuminates, the motor is running at medium speed. Press the button again, the motor stop.
- Press the button "High", the inner indicator light of switch illuminates, the motor is running at high speed. Press the button again, the motor stop.
- Press the button "Light", both lights switch on. Press the button again, the lights are switched off.

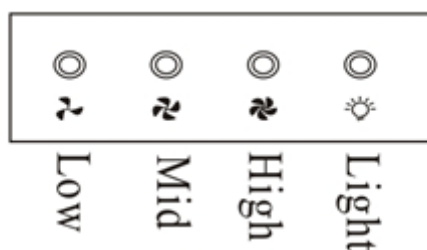

Maintenance

It is recommended to operate the appliance prior to cooking.

There shall be adequate ventilation of the room when the cooker hood is used at the same time as appliances burning gas or other fuels(not applicable to appliances that only discharge the air back into the room.

It is recommended to leave the appliance in operation for 15 minutes after cooking is terminated in order to completely eliminate cooking vapours and odours.

If the appliance is not used, please turn off.

Don't have flames directly under the cooker hood.

Don't use or stop use if the appliance is damaged especially the power supply cord and the casing.

If the supply cord is damaged, it must be replaced by the manufacturer, its service agent or similarly qualified persons in order to avoid a hazard.

Don't immerse the appliance in liquid.

The exhaust air must not be discharged into a flue which is used for exhausting fumes from appliance burning gas or other fuels.

Regulations concerning the discharge of air have to be fulfilled.

The details concerning the method and frequency of cleaning.

In order to prevent fire hazard, it is recommendable to clean the filter at a maximum of 2 month intervals by carrying out the followings:

--Unplug before cleaning, then remove the filters from the cooker hood and wash them in a solution of water and neutral liquid detergent, leaving to soak.

-Rinse thoroughly with warm water and leave to dry.

-The filters may also be washed in the dishwasher.

The aluminum panels may alter in color after several washes. This is not cause for

customer complaint nor replacement of panels.

Clean the surface of the cooker hood regularly using cloth moistened with denatured alcohol or non abrasive liquid detergent. (Remark: There can not clear the motor and inside part.)

Replace filters approximately every 4 months.

There is a fire risk if cleaning is not carried out in accordance with the instruction.

Attention:

- Use 220-240V 50Hz power;
- Cut off the power before cleaning.
- Do not use fire to dry the filter or any other parts.
- Do not dismantle the filters
- If the plug wire or plug become damaged, you must use the specific flexible wire or contact the Caple service centre on 0844 800 3830

GUARANTEE CONDITIONS

Caple undertake that if within twelve months of the date of the purchase this built-in appliance or any part thereof that is proved to be defective by reason only of faulty workmanship or materials, the company will, at our option repair or replace the same FREE OF ANY CHARGE for labour, materials or carriage on condition that:

- Documentation must be provided BEFORE a guarantee repair is commenced that the extractor is within the 12 month guarantee period.
- The appliance has been correctly installed and used only on the electrical supply stated on the rating plate.

- The appliance has been used for normal domestic purposes only, and in accordance with the manufacturer's operating and maintenance instructions.
- The appliance has not been serviced, maintained, repaired, taken apart or tampered with by any person not authorised by us.
- All service work under this guarantee must be undertaken by Caple Service Centre.
- Any appliance or defective part replaced shall become the property of this company.
- Home visits are made between **8.30am and 5.30pm Monday to Friday.**
- **If a service call is made and it is found that the installation has not been carried out correctly or customer misuse/abuse is involved THE COST OF THE SERVICE CALL HAS TO BE PAID FOR BY THE USER BEFORE ANY SERVICE WORK IS CARRIED OUT.**

EXCLUSIONS

This Guarantee does not cover:

- Damage or calls resulting from transportation, improper use or neglect, the replacement of any light bulbs or removable parts of glass or plastic.
- Costs incurred for calls to put right appliances improperly installed or calls to appliances outside the United Kingdom.
- Appliances found to be in use within a commercial environment, plus those which are the subject of rental agreements.
- This guarantee is in addition to your statutory and legal rights.

Caple Products

Service Centre Tel: 0870 800 3830

www.caple.co.uk