



Instruction manual for wall chimney hood

Model code: CCH7 & CCH10



Contact Caple on 0844 800 3830 or for spare parts www.4caple.co.uk

YOUR APPLIANCE

Thank you for buying your new Cape Chimney Extractor.

To ensure that you get the best results from your new Chimney Extractor, we strongly suggest that you read this instruction manual thoroughly before use.

This manual contains installation advice, usage instructions and a cleaning guide, as well as other important facts about your Cape Chimney Extractor.

If treated with care, your Cape Chimney Extractor should give you years of trouble-free use.

To register ownership, please ensure you complete and return the guarantee card supplied with the appliance.

These cooker hoods are designed to extract unpleasant odours from the kitchen; they are not intended to extract steam.

Note: CE Marking certifies that this appliance complies with the requirements laid down in EEC directive 89:336. (Electromagnetic compatibility) and subsequent modifications and Low Voltage directive 72/23/E.

IMPORTANT SAFETY INFORMATION

These warnings are provided in the interests of your safety. Ensure that you understand them all before installing or using this appliance. Your safety is of paramount importance. If you are unsure about any of the meanings of these warnings contact the Customer Care Department.

Installation

- § Installation work must be undertaken by a qualified electrician or a competent person.
- § Electrical connection must be by a qualified electrician.
- § This hood must be installed in accordance with the installation instructions and all measurements must be adhered to.
- § If the cooker hood is installed for use above a gas appliance then the provision for ventilation must be in accordance with the Gas Safety Codes of Practice BS.6172, BS.5440 and BS.6891 (Natural Gas) and BS.5482 (LP Gas) 1994, the Gas Safety (Installation & Use) Regulations, the Building Regulations issued by the Department of the Environment, the Building standards (Scotland) (Consolidated) Regulations issued by the Scottish Development Department.
- § The fan motor of this cooker hood incorporates a cut out device which will operate if the motor becomes overheated. If the cut-out device is activated, switch off the fan motor and allow the cooker hood to cool. The cut-out device will reset itself when the fan motor has cooled significantly.
- § It is dangerous to alter the specifications or modify this product in any way.
- § When installed between adjoining wall cabinets the wall cabinets must not overhang the hob.
- § If the room where the hood is to be used contains a fuel burning appliance such as a central heating boiler then its flue must be of the room sealed or balanced flue type.
- § If other types of flue or appliances are fitted ensure that there is an adequate supply of air to the room.
- § The ducting system for this appliance must not be connected to any existing ventilation system which is being used for any other purpose.
- § This extractor is supplied with flexible ducting that extends to 2 metres.
- § If site conditions make it necessary to extend the length, the size of the additional ducting must not be of a lesser cross sectional area and the ducting outlet must provide minimal flow resistance. Failure to follow this instruction will increase the noise level and overload the motor. **THE GUARANTEE WILL ALSO BE INVALIDATED.**

Child Safety

- § This appliance is designed to be operated by adults. Children should not be allowed to tamper with the controls or play with the appliance.

During Use

- § This product is for domestic use only.
- § Never leave frying pans unattended during use as over-heated fats and oils might catch fire.
- § Never do flambé cooking under this cooker hood.
- § Do not leave naked flames under the hood.

Maintenance and Service

- § This appliance can be a hazard if the metal filters are not washed regularly.
- § If charcoal filters are fitted the type and frequency of cooking will determine when the charcoal filter will require changing. In any case, these must be replaced every three/four months.
- § Under no circumstances should you attempt to repair the appliance yourself. Repairs carried out by inexperienced persons may cause injury or more serious malfunction. Refer to your Caple Service Centre.

OPERATING INSTRUCTIONS

To obtain the best performance it is advisable to switch the hood on for a few minutes before you start cooking and leave it running for approximately 15 minutes after cooking.

Push buttons



- § Push the **Low button** and the motor runs at low speed.
- § Push the **Mid button** and the motor runs at mid speed.
- § Push the **High button** and the motor runs at high speed.
- § Push the **Light button** and the two tungsten lamps light. Push it again and the lamps will turn off.
- § Push the **On/Off button** to turn off the lights and motor.

Recirculation

- § If the cooker hood is to be used in the recirculation mode the special charcoal filter must be used. This is available from your supplier as an accessory.
- § The contaminated air is cleaned by passing through the filters and then back into the kitchen.
- § The charcoal filter absorbs odours arising from cooking.
- § In use it will slowly become saturated in grease and less effective.
- § The charcoal filter normally requires changing after at least every three/four months or more frequently if the hood is used for more than three hours per day.

Extraction

- § The contaminated air enters the cooker hood passing through the metal grease filter and out through the ducting into the atmosphere.
- § When used in the extraction mode the **charcoal filter must not be fitted**.
- § Never do flambé cooking under this cooker hood.
- § Take extra care when frying and never leave frying pans unattended during use, as over-heated fats and oils can catch fire.
- § Do not leave naked flames under the cooker hood.
- § Ensure heating areas on your hob are covered with pots and pans when using the hob and cooker hood simultaneously.
- § Ensure not to damage the charcoal filter when cleaning or replacing as the activated charcoal inside is saturated with grease, which will stain if it comes into contact with clothing or furnishings.
- § Before carrying out any maintenance or cleaning isolate the cooker hood from the mains electricity supply.
- § The cooker hood must be kept clean, a build up of grease or fat can be a fire hazard.

MAINTENANCE AND CLEANING

External Cleaning

- § The metal casing, grill and chimney should be cleaned at least once a month to keep it looking like new. Wipe over the hood with a soft cloth wrung out in mild soapy water and then dry thoroughly.
- § Never use scouring pads or abrasive cleaners as they may scratch or damage the surfaces.
- § Always wear protective gloves when cleaning the hood.
- § Never use excessive amounts of water when cleaning particularly around the control panel.

Metal Grease Filter

- § The metal grease filter should be cleaned at least every month. The filter may be washed by hand using mild soapy water, or can be machine washed in a dishwasher.
- § Remove the metal grease filter cassette by pushing inwardly on the two steel handles; replace, making sure the

handle has sprung back into position and is completely visible.

Charcoal Filter (for re-circulation use only)

- § This is not supplied with the extractor and should be purchased from your supplier as an accessory.
- § The charcoal filter cannot be cleaned; it should be replaced approximately every three months or more often if the hood is used for more than three hours per day.
- § To remove the charcoal filter push inwardly on the two retaining clips to disengage the security fixing and remove.
- § This appliance can be a fire hazard if the grease and charcoal filters are not cleaned and replaced as recommended.

LIGHTING

Tungsten lighting

- § The lamps should be replaced with 220-240V 40W SES lamps.
- § To Remove the Lamps: -
 - Turn off the mains power supply to the extractor.
 - Remove metal grease filters
 - Remove lamps by unscrewing anticlockwise.
- § Replace with new lamp screwing in clockwise.
- § Refit metal grease filters.
- § Turn on power supply.

TROUBLESHOOTING

If, having followed these instructions carefully, your cooker hood fails to work properly please carry out the following checks.

Symptom	CHECK
The cooker hood will not start	§ Check the hood is connected to the electricity supply. § Check that the fan speed control is set to 1, 2 or 3.
The cooker hood is not working effectively	§ The fan speed is set high enough for the task. § The grease filter is clean. § The kitchen is adequately vented to allow the entry of fresh air. § If set up for recirculation, check that the charcoal filter is still effective. § If set up for extraction, check that the ducting and outlets are not blocked.
The cooker hood has switched off during operation.	§ The safety cut-out device has been tripped. § Turn off the hob and then wait for the device to reset.

- If after all these checks, the problem persists, telephone the **Caple Service Centre 0870 241 1142**, quoting the model and serial number.
- Please note that it will be necessary to provide proof of purchase for any in-guarantee service calls.
- **In-guarantee customers should ensure that the above checks have been made as the engineer will make a charge if the fault is not a mechanical or electrical breakdown.**

ELECTRICAL CONNECTIONS

Electrical Requirements

§ Any permanent electrical installation must comply with the latest I.E.E. Regulations. For your own safety this should be undertaken by a suitably qualified electrician who is on the roll of the National Inspection Council for Electrical Installation Contracting (NICEIC).

§ **THIS PRODUCT MUST BE CORRECTLY EARTHED.** The connection must be made as follows: -

- **Brown** = **Live**
- **Blue** = **neutral**
- **Yellow/Green** = **Earth**

Electrical Connection

§ Before connecting to the mains supply ensure that the mains voltage corresponds to the voltage on the rating plate inside the cooker hood.

§ This appliance is fitted with a 13 amp plug for connection to a suitable outlet which should be positioned for easy access.

§ If it is intended to connect directly to the electricity supply, the plug should be removed and the 3 core mains cable and should be permanently connected to the electricity supply via an approved Switched Fused Spur outlet meeting BS1363 Part 4, fitted with a 3 Amp fuse.

§ This appliance conforms to BS 800: 1988 and EEC Directive No. 78 308 regarding suppression of radio and television interference.

INSTALLING THE COOKER HOOD

- § It is dangerous to alter the specifications or attempt to modify this product in any way.
- § Please ensure that when the appliance is installed it is easily accessible to an engineer in the event of a breakdown.
- § All installations must comply with the local authority's requirements for the discharge of exhaust air.
- § Incorrect installation may affect the safety of this cooker hood.

Installation Requirements

- § Before installation, check the wall to which the cooker hood is to be fitted to ensure that there are no electric cables, water pipes or gas pipes that will be damaged by the fixing screws for the mounting bracket.
- § The cooker hood is designed to be fixed to a solid block or brick wall. If the wall is of a different construction, suitable fixings must be used.
- § The hood can be used in the extraction (ducted to the outside) or recirculation (internal recycling) mode.
- § The Installation work must be undertaken by a qualified and competent person. The manufacturer disclaims any responsibility to damages due to incorrect installation of the cooker hood or if the cooker hood is not installed in compliance with relevant regulations controlling this type of installation.

Unpacking

Before unpacking the cooker hood position the carton with the arrows pointing upwards as illustrated on the carton.

EXTRACTOR INSTALLATION REGULATIONS

Clearance Heights

- This cooker hood is designed to be fitted over a cooking appliance at the clearance heights stated.
 - Electric hob not exceeding **7kw** a clearance height of **650mm** is required
 - Gas hob not exceeding **10kw** a clearance height of **650mm** is required.
- If the output of the appliance below the cooker hood exceeds the maximum outputs quoted for **each kW in excess of 10kw the distance between extractor and gas hob must be increased by 10cm.**

However it is the manufacturer of the gas hob who determines the clearance required between hob & extractor and the clearance quoted by the gas hob manufacturer must be followed.

- There is no mandatory clearance for electric hobs and the clearance as quoted above should be followed.
- If the hob manufacturer provides no instructions, cannot provide the installer with the dimension or, in the case of an old hob, no dimensions can be found; the installer must follow the BS 6172 "Default Standard" and ensure that a clear "box", as in the illustration below, exists above and around hob.

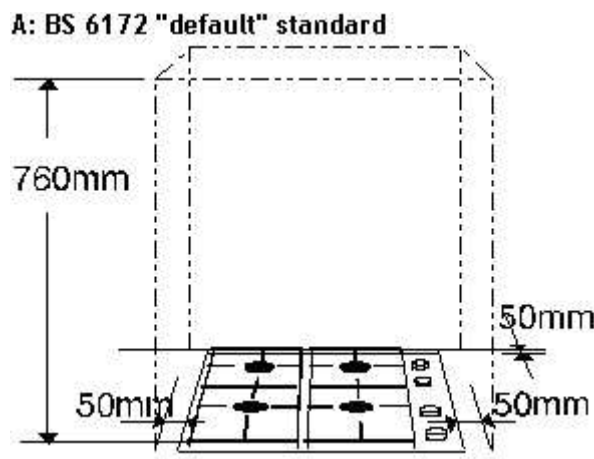

Note: The 760mm clearance is between the top of the burners and combustible material and not from the worktop. In practice, since the burners are usually 30-40mm above the level of the worktop, this means the clearance is effectively 790-800mm.

Caple undertake that if within twelve months of the date of the purchase this built-in appliance or any part thereof that is proved to be defective by reason only of faulty workmanship or materials, the company will, at our option repair or replace the same FREE OF ANY CHARGE for labour, materials or carriage on condition that:

- § Documentation must be provided BEFORE a guarantee repair is commenced that the extractor is within the 12 month guarantee period.
- § The appliance has been correctly installed and used only on the electrical supply stated on the rating plate.
- § The appliance has been used for normal domestic purposes only, and in accordance with the manufacturer's operating and maintenance instructions.
- § The appliance has not been serviced, maintained, repaired, taken apart or tampered with by any person not authorized by us.
- § All service work under this guarantee must be undertaken by Caple Service Centre.
- § Any appliance or defective part replaced shall become the property of this company.
- § Home visits are made between **8.30am and 5.30pm Monday to Friday.**
- § **If a service call is made and it is found that the installation has not been carried out correctly or customer misuse/abuse is involved THE COST OF THE SERVICE CALL HAS TO BE PAID FOR BY THE USER BEFORE ANY SERVICE WORK IS CARRIED OUT.**

EXCLUSIONS

This Guarantee does not cover:

- § Damage or calls resulting from transportation, improper use or neglect, the replacement of any light bulbs or removable parts of glass or plastic.
- § Costs incurred for calls to put right appliances improperly installed or calls to appliances outside the United Kingdom.
- § Appliances found to be in use within a commercial environment, plus those which are the subject of rental agreements.
- § This guarantee is in addition to your statutory and legal rights.

Caple Products

Service Centre Tel: 0844 800 3830
www.caple.co.uk