



FSCHSS8

Caple Standard Extractor



Technical Manual



FSCHSS8

Caple Standard Extractor

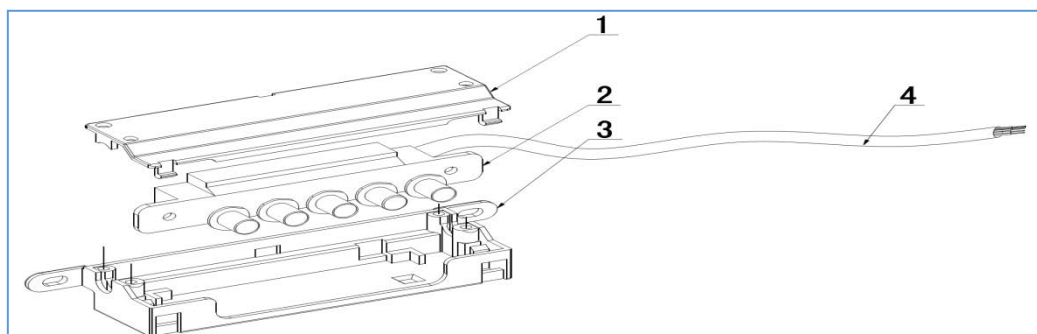
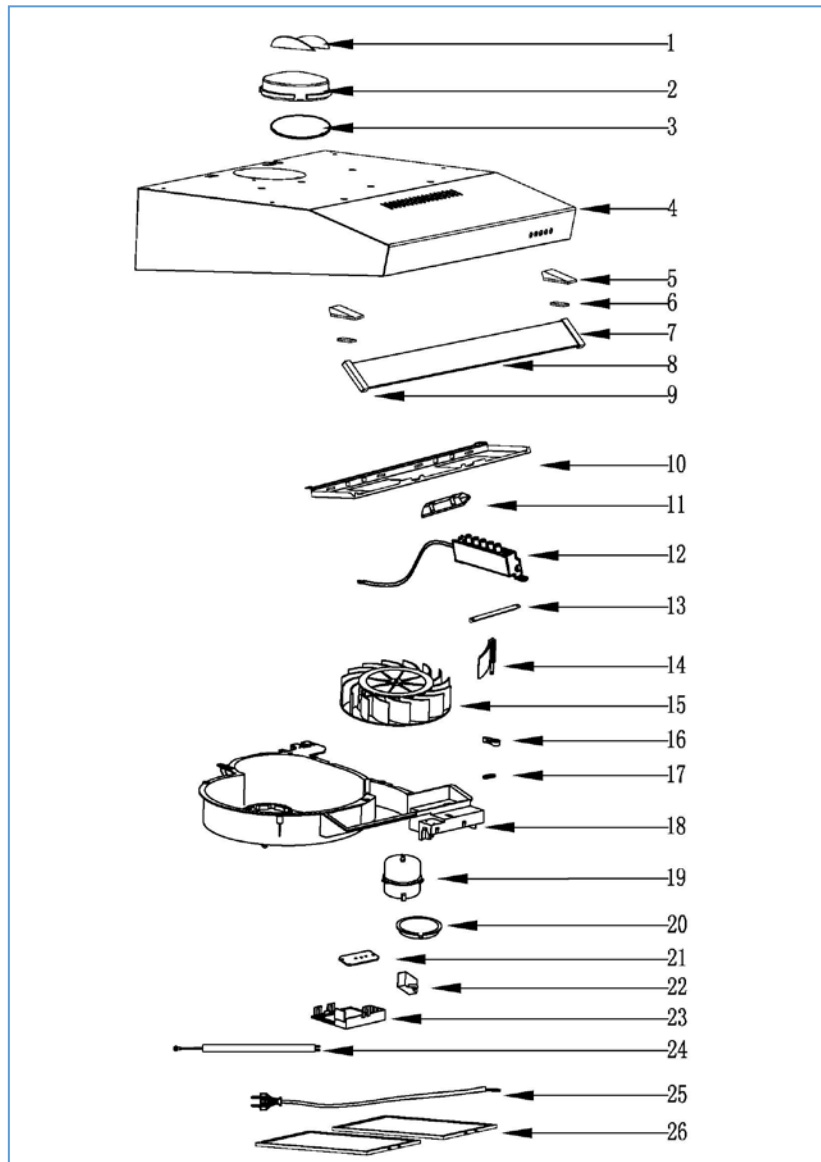



FSCHSS8

Caple Standard Extractor

Item	Part Number	Description	Quantity
1	B30-2903-026-0	One-way Valve Flap(120mm Air Outlet)	2
2	B30-2903-025-0	120mm Air Outlet	1
3	B30-2903-036-0	120mm Air Outlet cover	1
4	B10-2905-133-Q	430# S.S. Housing	1
5	B30-2903-062-3	Glass support (right)	1
6	B30-2903-071-3	Glass support lid	2
7	B30-2903-072-3	Glass support shelf right	1
8	B33-2903-070-0	600mm glass visor	1
9	B30-2903-060-3	Glass support (left)	1
10	B20-2903-174-P	Lamp board	1
11	B62-2401-592-0	LED lamp	1
12	B76-4903-002-B	Mechanical Switch Assembly	1
13	B23-2905-059-P	Switch Shelf	1
14	B30-2918A-017-0	Re-circulation vent flap	1
15	B30-2918A-015-0	Blower	1
16	B30-2903-017-0	Strip-type knob	1
17	B30-2918A-030-0	Motor housing holder	1
18	B30-2918A-011-0	Motor housing	1
19	B61-2401-470-0	Motor	1
20	B30-2918A-018-0	PCB Box Lid	1
21	B63-2501-044-0	Connection plug HJ-CO1-0	1
22	B64-2401-204-0	Motor capacitor (1.5uf)	1
23	B30-2918A-013-0	Motor housing cover	1
24	B62-2401-365-0	LED Lamp cable	1
25	B62-2903-119-0	UK BS plug cable	1
26	B35-2905-050-0	Grease filter	1
For Mechanical switch (B76-4903-002-B)			
1	B30-2201-090-0	Switch box cover lid	1
2	B60-2401-195-0	Push button	1
3	B30-2201-089-0	Push button bottom	1
4	B62-2401-145-0	Switch Cable	1

AC 220-240V 50HZ

