



# FGC720

Caple SS & Glass Extractor



Technical information



# FGC720

Cable SS & Glass Extractor

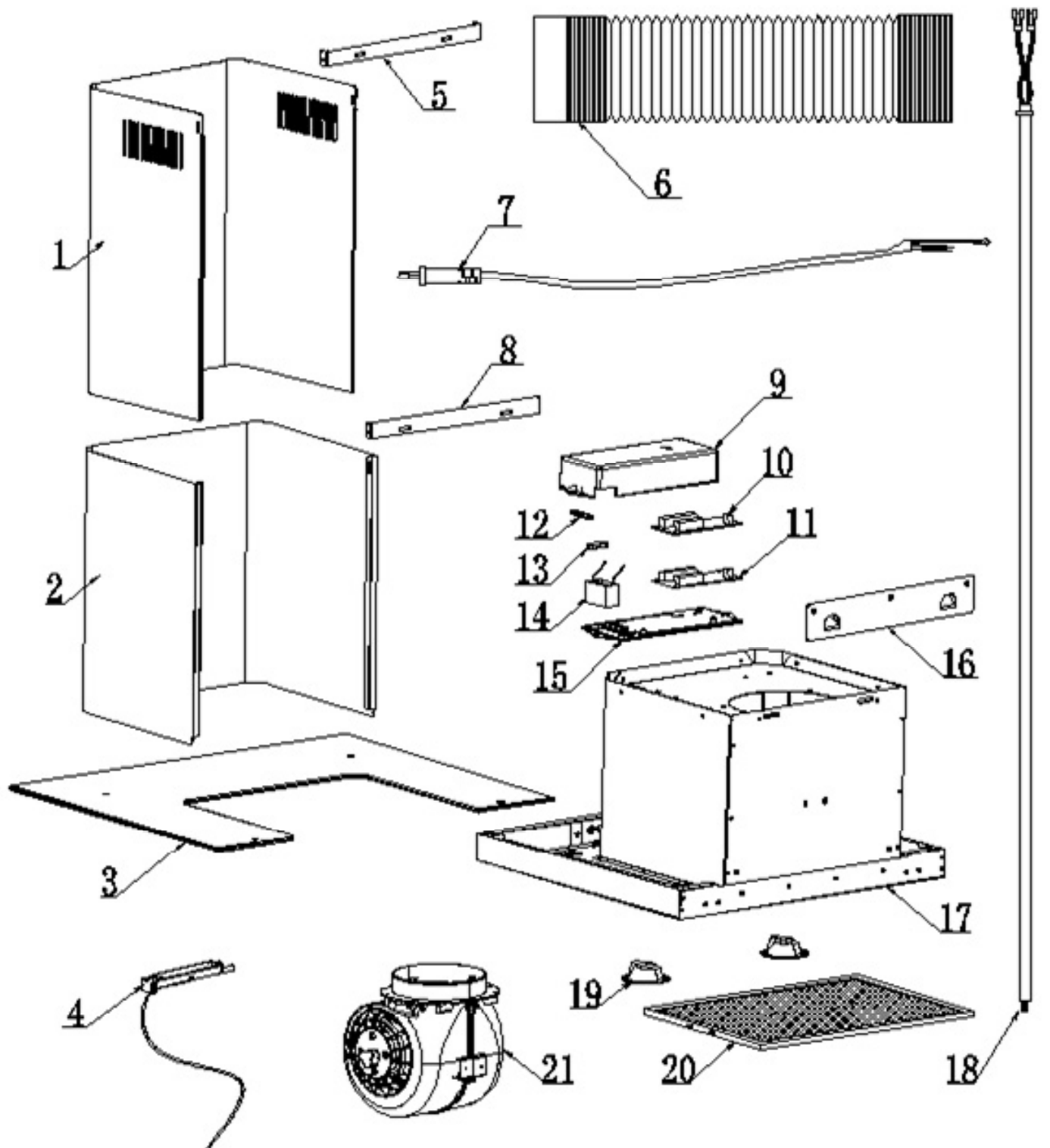

## Motor Assembly

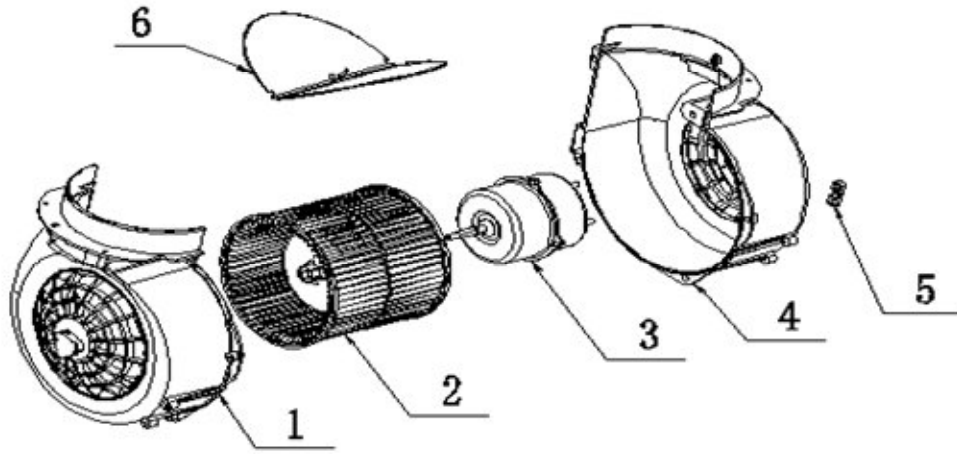

## Switch Assembly

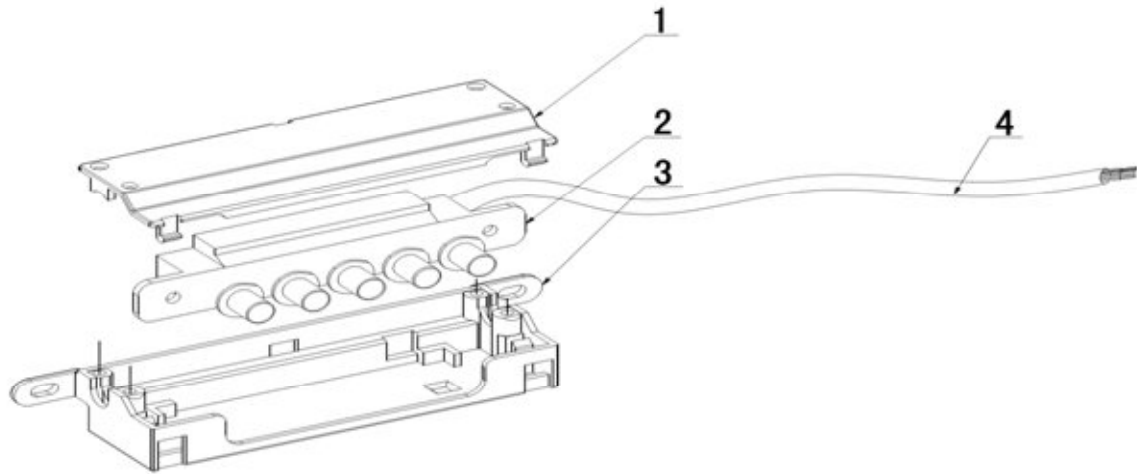

## Chassis Assembly

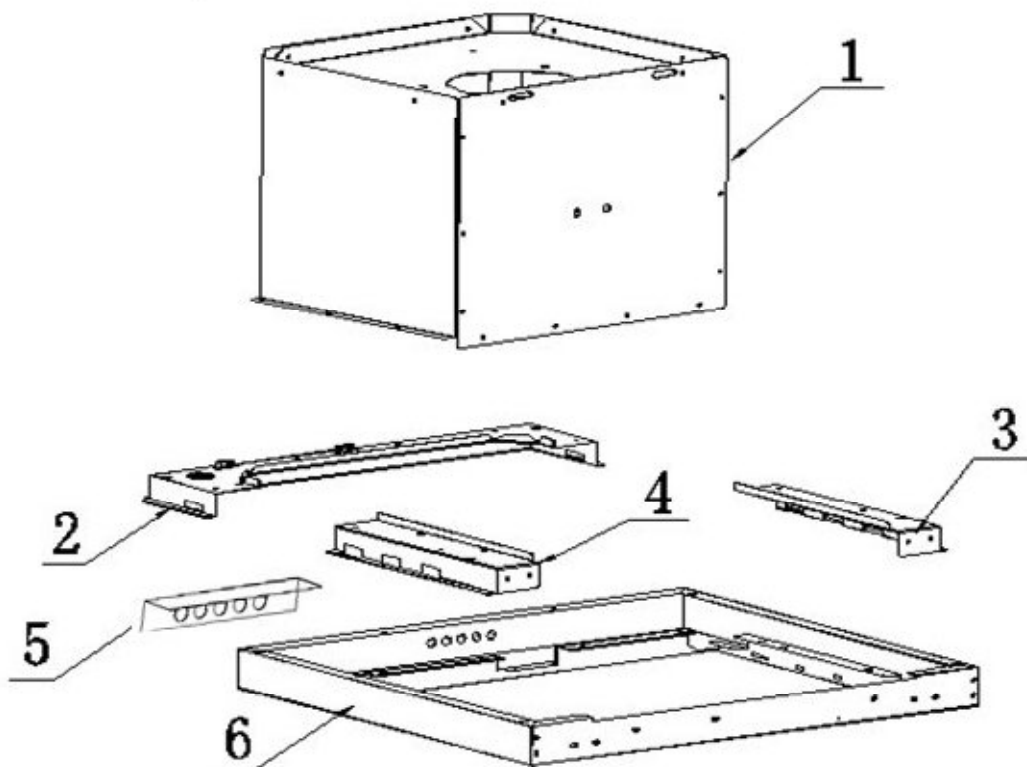



## FGC720 - Caple SS & Glass Extractor

Item	Part Code	Description	Qty
1	B20-2102-036-P	Upper chimney square corner	1
2	B20-2102-008-P	lower chimney square corner	1
3	B33-2601-034-0	Glass 700mm	1
4	B76-4102-002-B	Mechanical Switch Assembly	1
5	B23-2501-029-P	upper chimney Support Bracket	1
6	B36-2201-040-0	φ153风管	1
7	B62-2602-043-0	Cable with BS plug	1
8	B23-2501-031-P	lower chimney support bracket	1
9	B30-2501-034-0	PCB box Cover	1
10	B63-2501-041-0	transformer	1
11	B63-2501-044-0	sigle motor Wire box cover	1
12	B30-2501-035-0	PCB Box wiring holder	1
13	B30-2201-068-0	motor housing wiring holder	1
14	B64-2301-024-0	Motor capacitor(6.0μF)	1
15	B30-2501-025-0	PCB Box bottom	1
16	B23-2201-012-P	Hanger	1
17	B71-4601-002-B	Chassis assembly	1
18	B62-2602-022-0	LED Lamp cable	1
19	B62-2602-036-0	LED (Warm Color)	2
20	B35-2602-019-0	al.filters	1
21	B76-4102-001-B	Motor Assembly 750m3/H	1
1.0	B76-4102-001-B	For motor accessory	1
1.1	B30-2301-012-0	motor housing left	1
1.2	B30-2301-014-0	blower	1
1.3	B61-2301-039-0	Motor (#750-2)	1
1.4	B30-2301-013-0	motor housing right	1
1.5	B30-2201-068-0	motor housin wire holder	1
1.6	B30-2201-022-0	One-way Valve Flap(Air Outlet)	2
2.0	B76-4102-002-B	For Mechanical switch	1
2.1	B30-2201-090-0	Switch box cover lid	1
2.2	B60-2501-089-0	Push button PU02	1
2.3	B30-2201-089-0	Push button bottom	1
2.4	B62-1601-010-0	Switch Cable	1
3.0	B71-4601-002-B	For Chassis assembly	1
3.1	B11-0501-002-B	Round casing	1
3.2	B23-2602-003-P	front support board	1
3.3	B23-2602-005-P	left support board	1
3.4	B23-2602-004-P	right support board	1
3.5	B23-2501-161-P	Push button shelf	1
3.6	B11-1601-004-Q	Front panel	1

Fixing Kit - B74-4102-001-B

