



CGC910SS

Caple 90cm curved glass hood



Technical information



CGC910SS

Caple 90cm curved glass hood

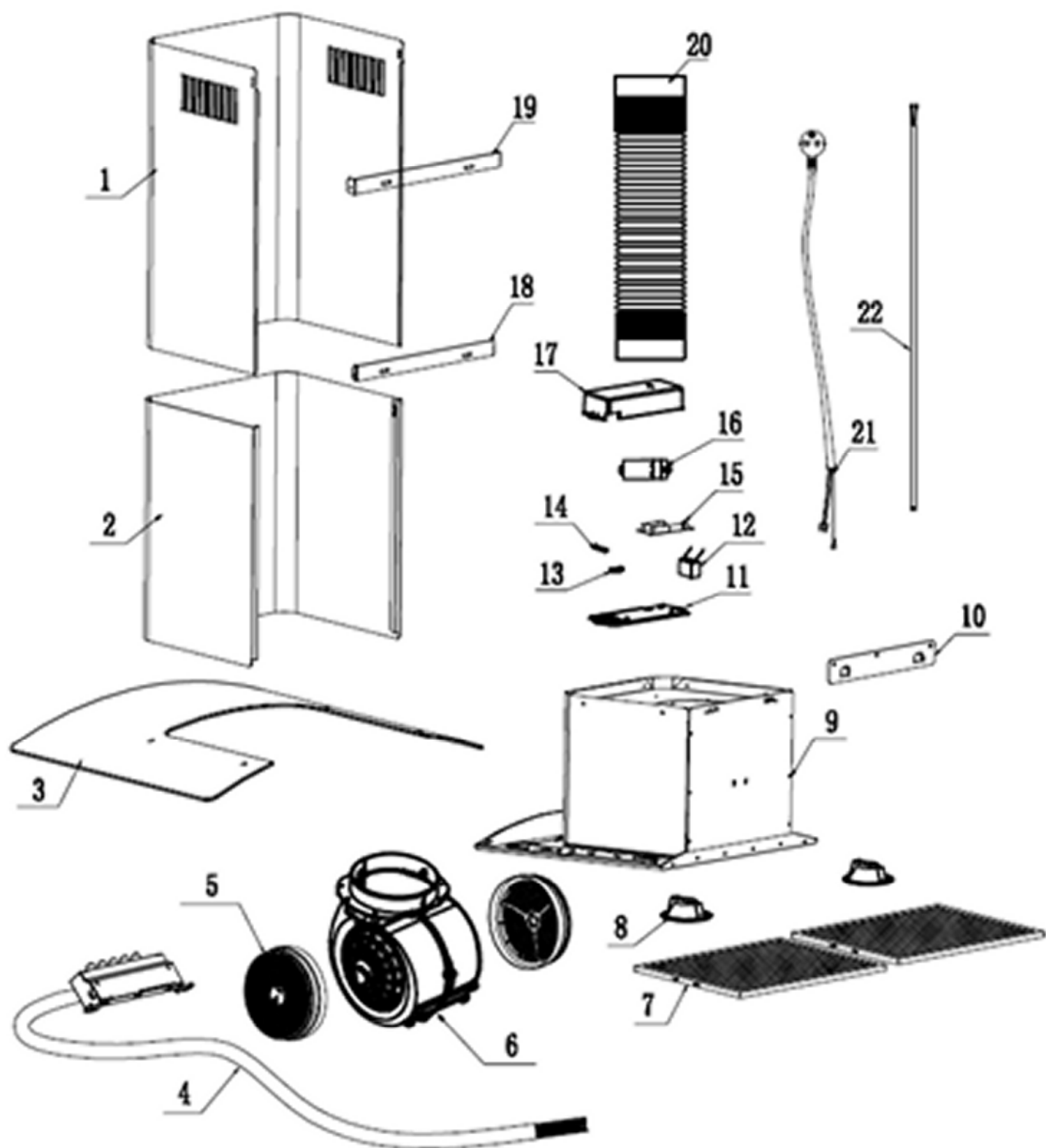

Motor assembly

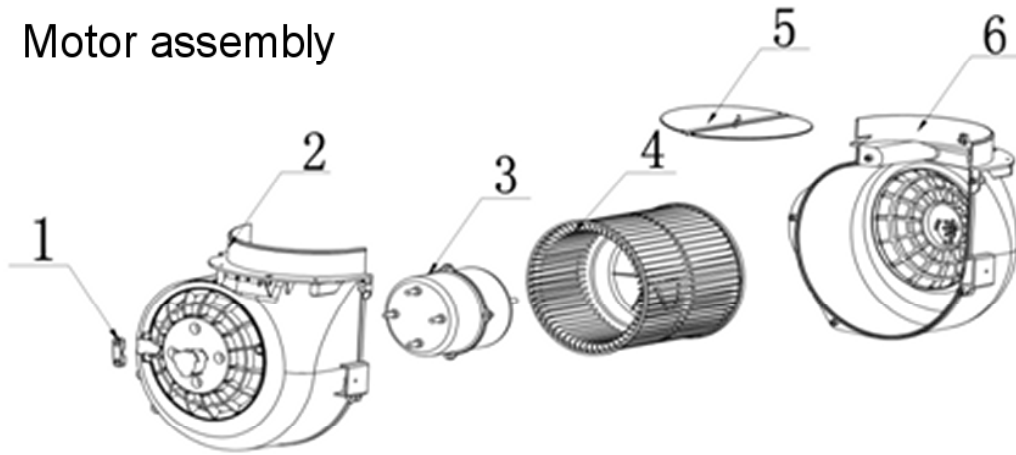

Switch assembly

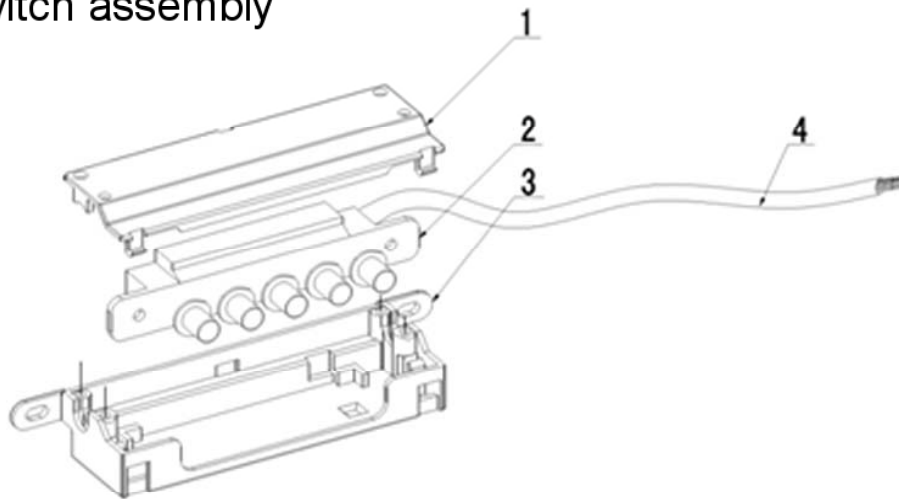

Chassis assembly

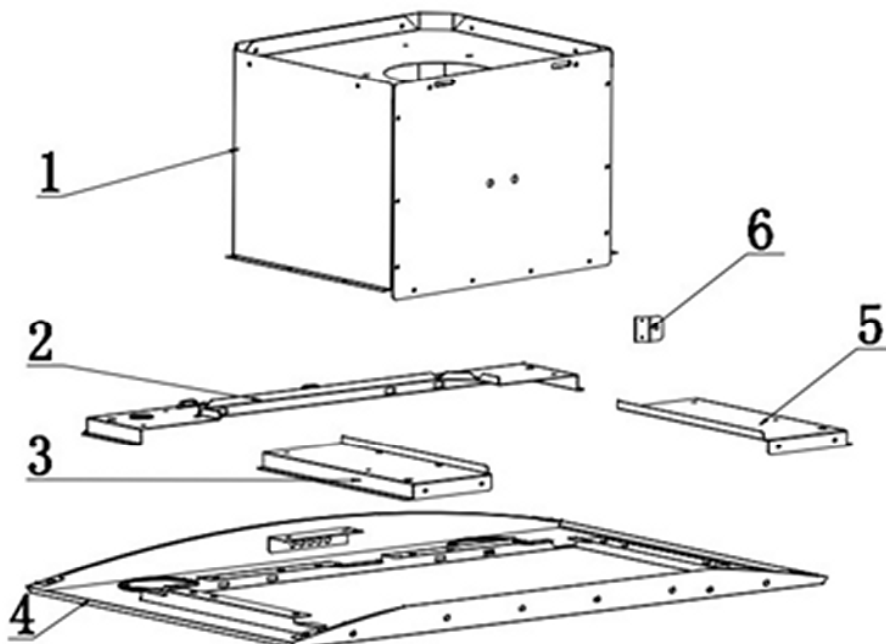



CGC910SS - Caple 90cm curved glass hood

Item	Part Code	Description	Qty
1	B20-2501-032-P	Upper Chimney (500mm height)	1
2	B20-2501-033-P	Lower Chimney (500mm height)	1
3	B33-2501-054-0	Glass	1
4	B76-4501-002-B	Mechanical Switch Assembly	1
5	B35-2501-014-0	Round carbon filter	2
6	B76-4102-003-B	Motor assembly(550m3h, 450mm cable)	1
7	B35-2501-022-0	Alu.Filter	2
8	B62-2401-175-0	LED Lamp (warm color)	2
9	B71-4501-008-B	Casing assemble	1
10	B23-2201-012-P	Hanging Board	1
11	B30-2501-025-0	PCB Box bottom	1
12	B64-2501-108-0	Motor capacitor (3uf)	1
13	B30-2201-068-0	Motor Holder	1
14	B30-2501-035-0	PCB Box wiring holder	1
15	B63-2501-044-0	Connection plug HJ-CO1-0	1
16	B63-2501-041-0	PCB (with transformer)	1
17	B30-2501-034-0	PCB Box Lid	1
18	B23-2501-031-P	Lower Chimney support bracket	1
19	B23-2501-029-P	Upper Chimney support bracket	1
20	B36-2201-040-0	?153 plastic pipe	1
21	B62-2602-043-0	UK BS plug cable	1
22	B62-2501-129-0	LED Lamp cable	1
For motor accessory?B76-4102-003-B?			
1	B30-2201-068-0	Motor holder	1
2	B30-2301-013-0	Motor housing(right)	1
3	B61-2401-286-0	Motor (#550-4)	1
4	B30-2301-014-0	Blower	1
5	B30-2201-022-0	One-way Valve Flap(Air Outlet)	2
6	B30-2301-012-0	Motor housing(left)	1
For Mechanical switch?B76-4501-001-B?			
1	B30-2201-090-0	Switch box cover lid	1
2	B60-2501-089-0	Push button	1
3	B30-2201-089-0	Push button bottom	1
4	B62-2501-090-0	Switch Cable(1300mm)	1
For Chassis assembly?B71-4501-008-B?			
1	B11-0501-002-B	Round casing	1
2	B23-2501-047-P	front panel support	1
3	B23-2501-049-P	support board-right	1
4	B11-2501-098-Q	front panel	1
5	B23-2501-051-P	support board-left	1
6	B23-2201-018-P	front support board	2

Fixing Kit - B74-4102-001-B