



CCH901SS

Caple 900mm Stainless Steel Chimney



Technical Manual



CCH901SS

Caple 900mm Stainless Steel Chimney

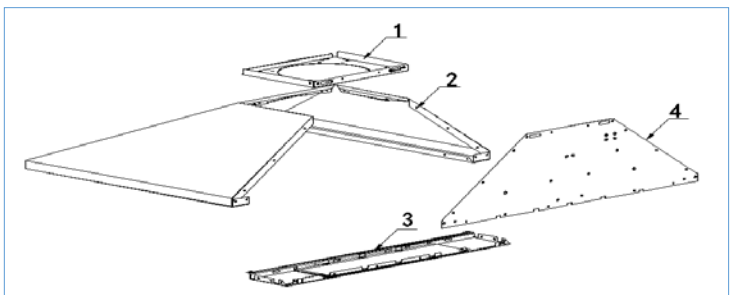
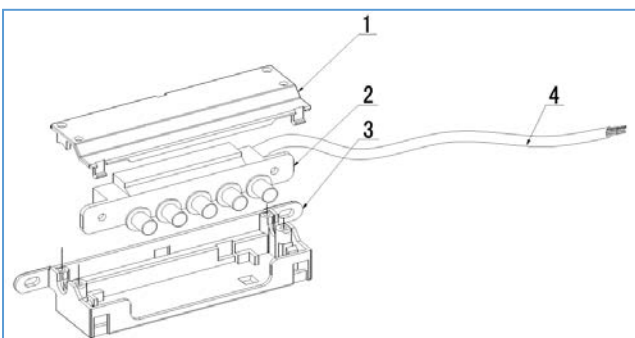
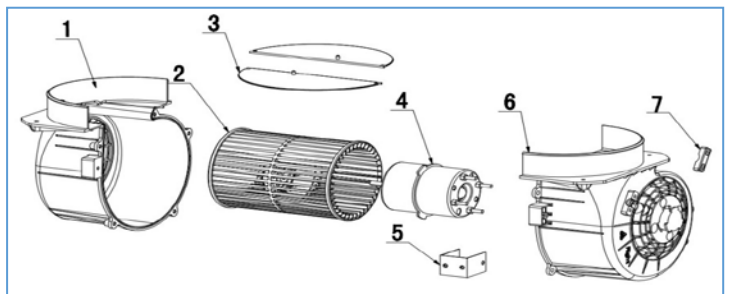
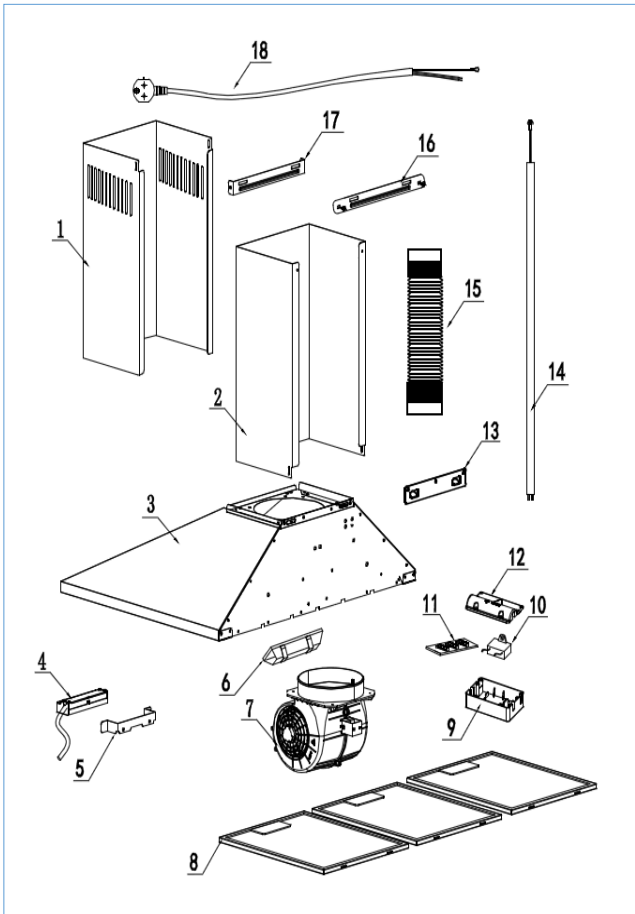



CCH901SS

Caple 900mm Stainless Steel Chimney

Item	Part Number	Description	Quantity
1	B20-2201-004-P	Upper Chimney (400MM height)	1
2	B20-2201-006-P	Lower Chimney (400MM height)	1
3	B71-4201-009-000-01-B	Casing Assembly	1
4	B76-4102-008-B	Mechanical Switch (PU01) Assembly	1
5	B23-2201-094-P	Switch shelf	1
6	B62-2401-592-0	LED lamp	1
7	B76-4201-003-B	Motor Assembly	1
8	B35-2802-021-0	Grease filter	3
9	B30-2301-139-0	Lamp connector cover	1
10	B64-2401-204-0	Motor capacitor(1.5 μ F)	1
11	B63-2501-044-0	Connecting plug	1
12	B30-2301-140-0	Connector upper cover	1
13	B23-2201-012-P	Hanging Board	1
14	B62-2401-365-0	LED Lamp cable	1
15	B36-2201-040-0	ϕ 153 Plastic Pipe	1
16	B23-2201-010-P	Lower Chimney Support Bracket	1
17	B23-2201-008-P	Upper Chimney Support Bracket	1
18	B62-2602-043-0	Plug with cable	1
For Motor accessory (B76-4201-003-B)			
1	B30-2201-065-0	Motor housing(left)	1
2	B30-2201-067-0	Blower	1
3	B30-2201-022-0	One-way Valve Flap(Air Outlet)	2
4	B61-2201-064-0	Motor (#350)	1
5	B23-2201-069-P	Motor housing holder	1
6	B30-2201-066-0	Motor housing(right)	1
7	B30-2201-068-0	Motor Holder	1
For Mechanical switch (B71-4201-009-000-01-B)			
1	B30-2201-090-0	Switch box cover lid	1
2	B60-2401-195-0	Push button PU01	1
3	B30-2201-089-0	Push button bottom	1
4	B62-2301-048-0	Switch Cable	1
For Chassis assembly (B71-4201-009-000-01-B)			
1	B23-2201-016-P	Round Casing Lid	1
2	B10-2201-175-Q	900mm Front Housing Panel	1
3	B20-2201-176-P	Lamp board	1
4	B23-2201-119-P	900mm Back Board	1

