



BXI910

Caple 90cm island hood

Technical information



BXI910

Caple 90cm island hood

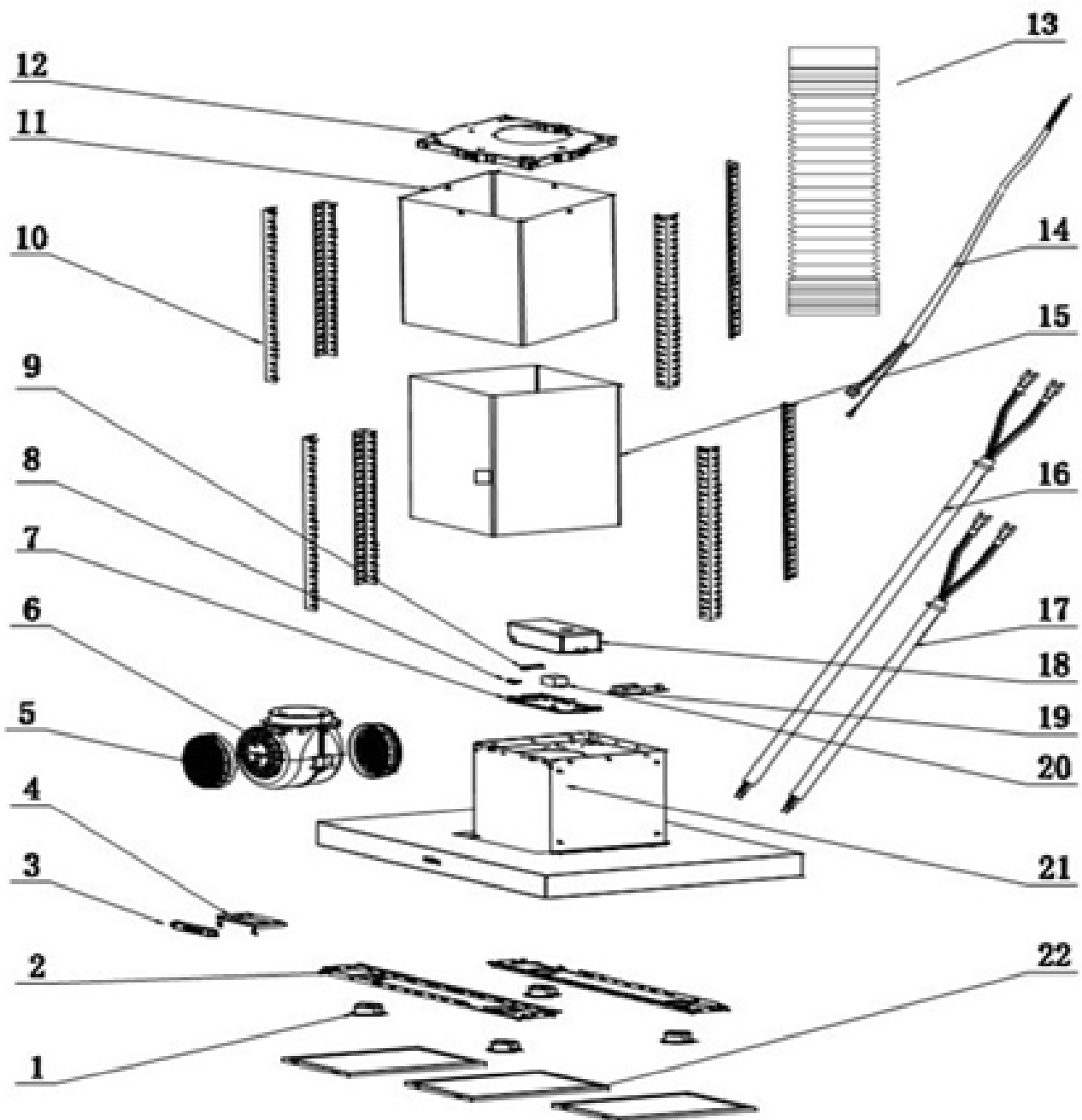

Motor Assembly

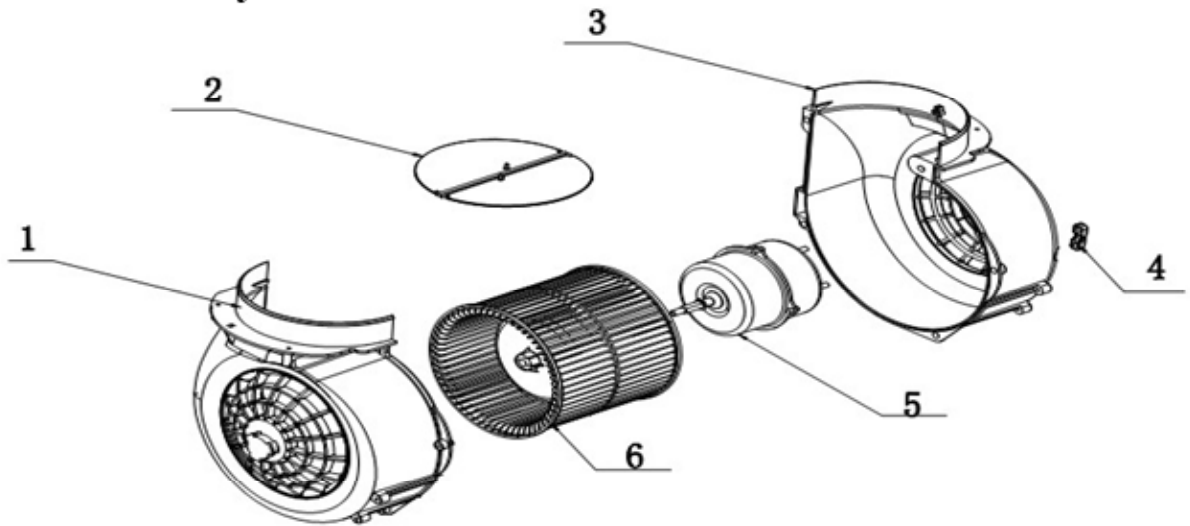

Switch Assembly

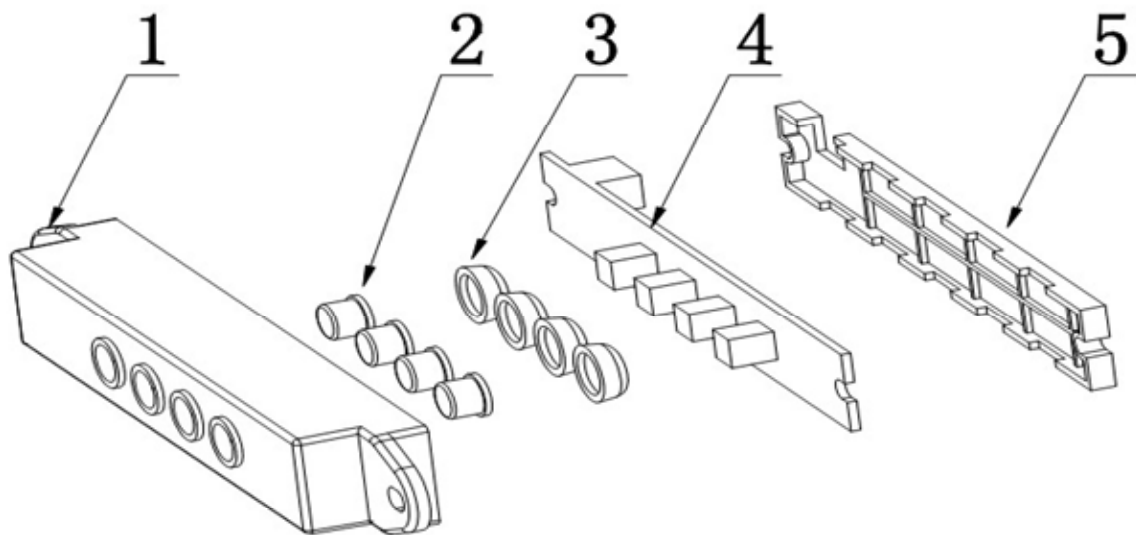

Chassis Assembly

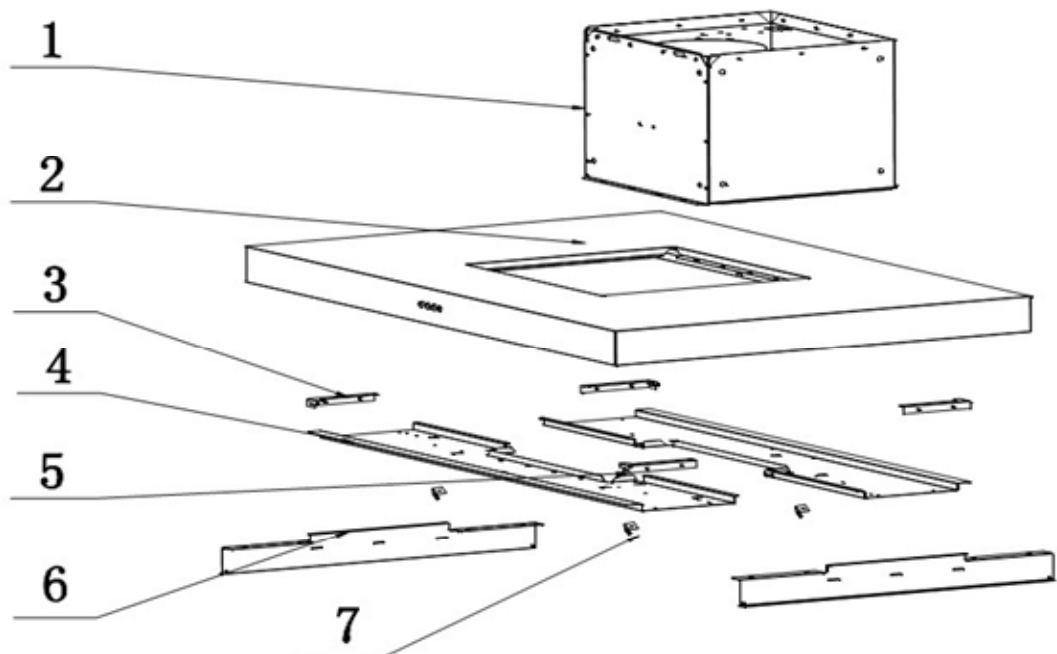



BXI910 - Caple Box Island 90cm Hood

Item	Part Code	Description	Qty
1	B62-2401-175-0	LED Lamp (warm color)	4
2	B20-2102-019-P	Lamp board	2
3	B76-4601-001-B	Electronic switch Assemble	1
4	B23-2802-003-P	Electronic switch Shelf	1
5	B35-2501-014-0	Carbon filter	2
6	B76-4109-001-B	Motor assembly	1
7	B30-2501-025-0	PCB Box bottom	1
8	B30-2201-068-0	Motor wiring holder	1
9	B30-2501-035-0	PCB Box wiring holder	1
10	B23-2801-015-0	Corner iron	8
11	B20-2802-006-P	Upper Chimney (600MM height)	1
12	B23-2801-002-P	CornerBoard	1
13	B36-2201-040-0	Ø153 plastic pipe	1
14	B62-2602-043-0	UK BS plug cable	1
15	B20-2802-007-P	Lower Chimney (600MM height)	1
16	B62-2802-009-0	Led Lamp cable-front	1
17	B62-2802-008-0	Led Lamp cable-back	1
18	B30-2501-034-0	PCB Box Lid	1
19	B63-2401-254-0	PCB Assembly HJ-E01-D-P	1
20	B64-2301-024-0	6µ F capacitor	1
21	B71-4802-001-B	Casing assembly	1
22	B35-2201-038-0	Alu.Filter	3
Motor accessory			
1.1	B30-2301-012-0	Motor housing(left)	1
1.2	B30-2201-022-0	One-way Valve Flap(Air Outlet)	2
1.3	B30-2301-013-0	Motor housing(right)	1
1.4	B30-2201-068-0	Motor housing holder	1
1.5	B61-2301-039-0	Motor 750-2	1
1.6	B30-2301-014-0	Blower	1
Mechanical switch			
2.1	B30-2602-026-0	Electronic Switch cover	1
2.2	B20-2602-028-0	S.S. button	4
2.3	B30-2602-027-0	Electronic Switch button	4
2.4	B63-2501-021-0	Button HJ-E04-D-S	1
2.5	B30-2602-025-0	Bottom of the electronic switch	1
Chassis assembly			
3.1	B11-0801-002-B	Round Casing Lid	1
3.2	B20-2802-002-P	Frame panel	1
3.3	B20-2301-004-P	Left corner plate	2
3.4	B23-2802-004-P	Frame Support(front and back)	2
3.5	B23-2802-005-P	Right corner plate	2
3.6	B20-2301-005-P	Support(left & right)	2
3.7	B23-2201-018-P	Hanging plate	3